

SOUTHERN
REGION

BULLETIN NO. 4



CAR
LOCATION
INVENTORY
CONTROL

Instructions - Maps

Enid, Oklahoma and
Stillwater Subdivisions

Revised April 1992

ENGINEERING AND
TECHNOLOGY DEVELOPMENT
KANSAS CITY

<u>Station</u>	<u>Stn. No.</u>	<u>Zone(s)</u>	<u>Page</u>
<u>OKLAHOMA SUB</u>			
Ardmore	51200	63	170-182
Arkansas City	52700	01-05	2-26
ASP	52090	46	54
Britton	51680	04	76
Crusher	51230	62	166
Davis	51250	62	160
Dougherty	51240	62	164
Edmond	51690	04	70-74
Flynn	51500	05	108-110
Flynn	51500	09	112-118
Flynn	51500	12	122-126
Flynn	51500	13	120
Gainesville	51100	65	190-194
Gene Autry	51225	63	168
Guthrie	51700	11	64-68
Kildare	52670	17	30
Lawrie	52050	71	62
Marland	52290	27	48
Marietta	51140	64	186
Midwest City	51590	10	140
Moore	51420	05	128
Mulhall	52060	11	60
Newkirk	52680	17	28
Noble	51410	05	134
Norman	51415	05	130-132
Oklahoma City	51500	01	82-84
Oklahoma City	51500	02	86-90
Oklahoma City	51500	03	78-80
Oklahoma City	51500	06	92-98
			104
Oklahoma City	51500	07	106
Oklahoma City	51500	08	100-102
Otoe	52270	36	54
Overbrook	51140	64	184
Paoli	51315	61	152
Pauls Valley	51300	60	154
Pauls Valley	51300	61	156
Perry	52100	45	56-58
Ponca City	52300	21-26	32-462
Purcell	51400	41	36-138
Rayford	51245	62	162
Red Rock	52280	30	50-52
Seward	51695	83	62
Shawnee	51600	37	142-148
Thackerville	51120	64	188
Wayne	51325	61	150
Wynnewood	51255	62	158
<u>Stillwater Sub</u>			
Glencoe	52115	52	200
Pawnee	52110	54	202
Stillwater	52120	50	196-198

Conductors and Engine Foreman will be furnished work orders during their tour of duty.

This document will specify the cars to be picked up or set out at various stations, industries or interchange tracks serviced by the train or switch job.

Certain information (described below) must be recorded on the work order document by the Conductor or Engine Foreman. Prior to turning in the document at the designated reporting station, it must be dated and signed even if no work was accomplished. This is necessary to comply with switching and demurrage tariffs as well as other rules and regulations.

- BO - Bad Order
- ND - Work Indicated Not Done (State Reason)
- NIT - Car Not in Train or Not on Track
- OTCC - Car on Track Carriers Convenience
- OTNP - Car on Track Not Placed
- PULL - Car Pulled, Time and Date
- SPOT - Car Spotted, Time and Date

Conductor/Engine Foreman must make notation on work order of any exceptions taken to the work order, such as no car, car not on list, car out of line, car is hazardous, excess dimensions (when the information is not so indicated on work order), car is carded ready for head end movement, or any other exceptions noted.

If switching is performed without a work order, the Conductor or Engine Foreman must complete the prescribed form showing all the information required above and turn it in at the designated reporting station.

If an industry requests service not shown on work order, Conductor/Engine Foreman should obtain such request in writing. This request is to be turned in with work order for processing. If unable to obtain request in writing, Conductor/Engine Foreman should record on work order the name of the person making request and the service requested and performed.

For observation and guidance, the following codes may appear on work order:

- AI - Agricultural Industries
- BI - Bad Order
- BA - Blasting Agent
- BT - Bare Table (no vans/containers)
- CD - Condemned
- CG - Cargill
- DG - Dangerous
- DH - Do Not Hump
- DU - Do Not Uncouple
- EC - Empty Container (speed restricted 55 mph)
- EQ - Union Equity or Equity Export, Houston
- FW - Flammable Solid "W" (Dangerous when wet)
- HE - Head End Only
- HL - High Wide Load
- HV - High Value
- IP - Interchange Prohibited
- IPSW - Intraplant Switch (Respot Car)
- LS - Handle in Local Service Only
- MRXX - Mechanical Refrigeration Maintain "XX" Degrees
- MCNR - Mechanical Car or Trailer - No Refrigeration Required
- ND - Do Not Divert
- NP - No Placards Required
- OR - Other Regulated Material
- OX - Oxygen
- PB - Poison
- PE - Houston Public Elevator
- RE - Rear End Only
- RM - Radioactive Material
- REJT - Car Rejected by Shipper
- RSPT - Respot Due to Railroad Error
- SO - Car/Van Billed Shippers Order
- TURN - Turn Car & Respot
- WH - Weigh Heavy
- WI - Waive Inspection - Set Direct
- WL - Weight Light
- XA - Explosive A
- XB - Explosive B
- XX - Do Not Move This Car
- ZZ - Cryogenic Liquid Subject to ATSF Operating Rule 103N

GOOD COMMUNICATION AND COMPLIANCE WITH
INSTRUCTIONS IS ESSENTIAL FOR A COMPLETE AND
SUCCESSFUL OPERATION. YOUR REPORTINGS ARE THE
KEY TO ACCURATE RECORDS. THE COMPLETE
COOPERATION OF EVERY EMPLOYEE IS SOLICITED AND
APPRECIATED.

<u>PATRON</u>	<u>STN.</u>	<u>PAGE</u>
A.M.P.I.	51800	239
A-K News	51500	87
Acco	51500	99
Acme Brick	51680	75
ADM Milling (east)	52700	15
ADM Milling (west)	52700	23
Agri Products	51200	171
Ahrberg Milling	52120	197
Allen-Bradley	51600	141
Allied Cement Co.	54100	203
Arco	51100	193
Armstrong	52120	195
B & L Cartage	51500	87
Ball Pipe & Supply	51600	145
Ballenger Furniture	51500	87
Bliss Coop	52290	47
Bluebonnet Milling Co	51200	175
Boersma Beverage Co	52300	197
Boersma Beer	52120	35
Box Crow Cement	51500	71
Bradford Industrial Sup	51500	85
Bunte Candy	51500	93
Burlington Coop	51870	205
C & P	52300	31,37
Cain Coffee	51680	75
Campbell Oil Co.	51200	175
Capital City Transfer	51500	101
Capital Steel	51500	99
Carlson Products	51500	113
Champion Builders	51500	85
City Garage	51500	99
Clements	51500	77
Coline	51200	169
Colley Co	51300	155
Comet Mills Store	51200	175
Comfort Inc	51500	87
Commercial Whse	51500	81
Conoco	52300	37,41
Continental Plastics	51500	87
Continental Grain Co	51800	235
Continental Carbon Black	52300	43
Coors Central	51415	129
Coors Central	51500	85
Corrugated Pkg & Design	51500	87
Crane Ammonia Coop	54100	203
Crescent Coop	51705	253
Crowley Tar	51500	109
Dale Distributing Co	51600	145
Data Documents	51500	85
Diamond Salt Co	51420	127
Dolese Brothers (Crusher)	51230	165
Dowell Chemical	51100	193
Dowell Co	51300	155
Drilling Mud	51800	239
Drilling Mud Co	51200	171
Dufek Aerial Spray	52280	49
Dupont	51500	85

<u>PATRON</u>	<u>STN.</u>	<u>PAGE</u>
Eason Oil	51800	239
Far Eastern Imports	51500	85
Farm Products	51100	193
Farm Enterprises	51700	65
Farm Ranch Grain Co	51300	155
Farm Enterprise	51705	253
Farmers Coop	52680	27
Farmers Coop	52670	29
Farmers Coop	51850	209
Farmers Coop	51840	213
Farmers Coop	51725	247
Farmers Coop	51735	245
Farmers Elevator	52280	49
Federal Ore & Chemical	51200	173
Fleming	51680	75
Fleming	51690	73
Fulton Supply	51100	193
G E O Drilling Co	51200	169
Gainesville Elevator	51100	191
Gainesville Foundry	51100	189
Gas & Electric Equipment	51500	87
General Supply Co	51800	239
General Electric	51500	85
General Motors Assembly	51500	117
Georgia Pacific Corp	51200	169
GMAD	51500	117
Gold Spot Dairy	51800	239
Gulf Oil	51100	193
Guthrie Cotton Oil	51700	63
H & H Co	51200	175
Halliburton Co	51250	159
Hillsdale Coop	51820	217
Hoffman Furniture	51420	127
Hope Lumber	51690	71
Hughes Drilling Supply	51200	171
Humphrey Implement	54100	203
Huttig Sash & Door	51500	85
IMC Drilling Mud	51140	185
IMCO Drilling	51200	173
International Paper	51690	69
J & M Cartage	51500	87
J & S Paper	51500	119
Jacobson Inc.	51300	155
Jeffrie Beer	52300	35
Kerr McGee	51255	157
Kiowa Implement	54100	203
Kirksey Wholesale Plywood	51300	155
Kraft Foods	51500	87
Kraft Foods Div	51500	77
Lains Feed Co	51140	185
Leonhardt Lbr	51690	71
Lincoln Electric	51500	101
Liquid Blenders	51100	193
Little Brownies Bakers	51140	185
Long Bell Lumber	51690	69
Lumberman Millwork	51200	173
Macklangurg-Duncan	51500	79
Magcobar	51200	171

<u>PATRON</u>	<u>STN.</u>	<u>PAGE</u>
Magcobar	51800	239
Makins Cement	51590	139
Marietta Feed	51140	185
Market Pre-Pak	51590	139
Martin Feed Co	51255	157
Martin Fertilizer	51300	153
MBM Inc	51500	109
Medallion Chemical	51500	85
Mercury Marine	52120	195
Merrico Grain Co	51225	167
Michael Oil Co	54100	203
Mid America Grain	51800	227
Milpark	51200	175
Mobil Chemical	51600	141
Modern Distributors	51500	85
Moore Business Forms	52120	195
Munster Mills	51100	193
Murphy Perkins	51690	71
Nabisco	51500	87
Nash Equity	51830	215
National Standard	52120	195
National Supply	51100	189
North Wood Furniture	51100	189
O.K. Coop	54100	203
Oberlin Color Press	52120	195
OG&E	51500	109
Oklahoma Gas & Electric	51300	155
Oklahoma Gas & Electric	51200	179
Oklahoma Iron Co	51200	171
Oklahoma Gas & Electric	52280	51
Otasco	51500	85
Paxton Lumber	51500	101
Payless Cashway	51500	111
Perry Elevator	52100	55
Phillips Petroleum	52300	35
Pillsburg, Inc.	51800	241
Pioneer Liquor	52300	35
Poly Pipe	51100	193
Ponca Iron Co.	52300	35
Pritchard Whse	51500	85
Pro Tread Corp	51500	85
Purcell Seed & Grain	51400	137
R.E.A.	51140	185
Ralston Purina	51690	73
Red River Farm Coop	51100	191
Safeway	51500	89
Santa Fe Sales Co	51500	81
Scrivner	51500	105
Shawnee Steel Co	51600	145
Shawnee Milling Co	51600	147
Sheffield Steel	51500	101
Skaggs Alpha Beta	52300	35
Skyline Homes	52700	19
Southwest Electric	51500	119
Southwest Stationary	51500	81
Standard Asbestos	51500	87

<u>PATRON</u>	<u>STN.</u>	<u>PAGE</u>
Stanley DX Warehouse	51200	171
Star Manufacturing	51500	107
Stillwater Milling	52120	197
Stillwater Milling Co	51250	159
Stockmans Mill & Grain	52110	201
Sysco Mid-Central	51500	87
Tex-O-Fertilizer	51100	89-191
Texaco	51300	153
Thomas, John Furniture	51500	87
Tinker AFB Receiving Tr	51590	139
Tinker AFB Delivery Tr	51590	139
Tony's Feed Store	51100	191
Total Petroleum	51200	169
Trinity	51500	99
Two Rivers Coop	52700	5
Uni-Royal	51200	179
Union Equity Elev A & B	51800	237
Union Equity Elev Y & Z	51800	229, 233
Union Carbide	51300	153
United Coop	51715	249
United Coop	51710	251
United Coop Elevator	52060	59
University of Oklahoma	51415	131
Vista Polymer Stge Lease	51500	107
Vista Polymer	51500	113
Waldeck Agrico	52700	19
Walter Paper, Jim	51500	85
Warren Transfer	51500	85
Waugh Brothers	51500	85
West Side Feed	51800	239
Western Paper	51500	87
Western Rock Products	51250	159
Western Co	51200	181
Weyerhaeuser	51500	111
White Building Materials	51600	143
Wilson Company	51500	101
Wolverine	51600	141

LEFT

BLANK

INTENTIONALLY

x

Zone 01 (Arkansas City 52700) Oklahoma Subidivision

01 01 00	Yard Track No. 1
01 02 00	Yard Track No. 2
01 03 00	Yard Track No. 3
01 04 00	Yard Track No. 4
01 05 00	Yard Track No. 5
01 06 00	Yard Track No. 6
01 07 00	Yard Track No. 7
01 08 00	Yard Track No. 8
01 09 00	Yard Track No. 9
01 10 00	Yard Track No. 10
01 11 00	Yard Track No. 11
01 29 00	Material Yard Lead Track
01 98 00	Siding
01 99 00	Main Track

Page 1

C.E. NO. 12619-SK Engineering & Technology Development 4/92

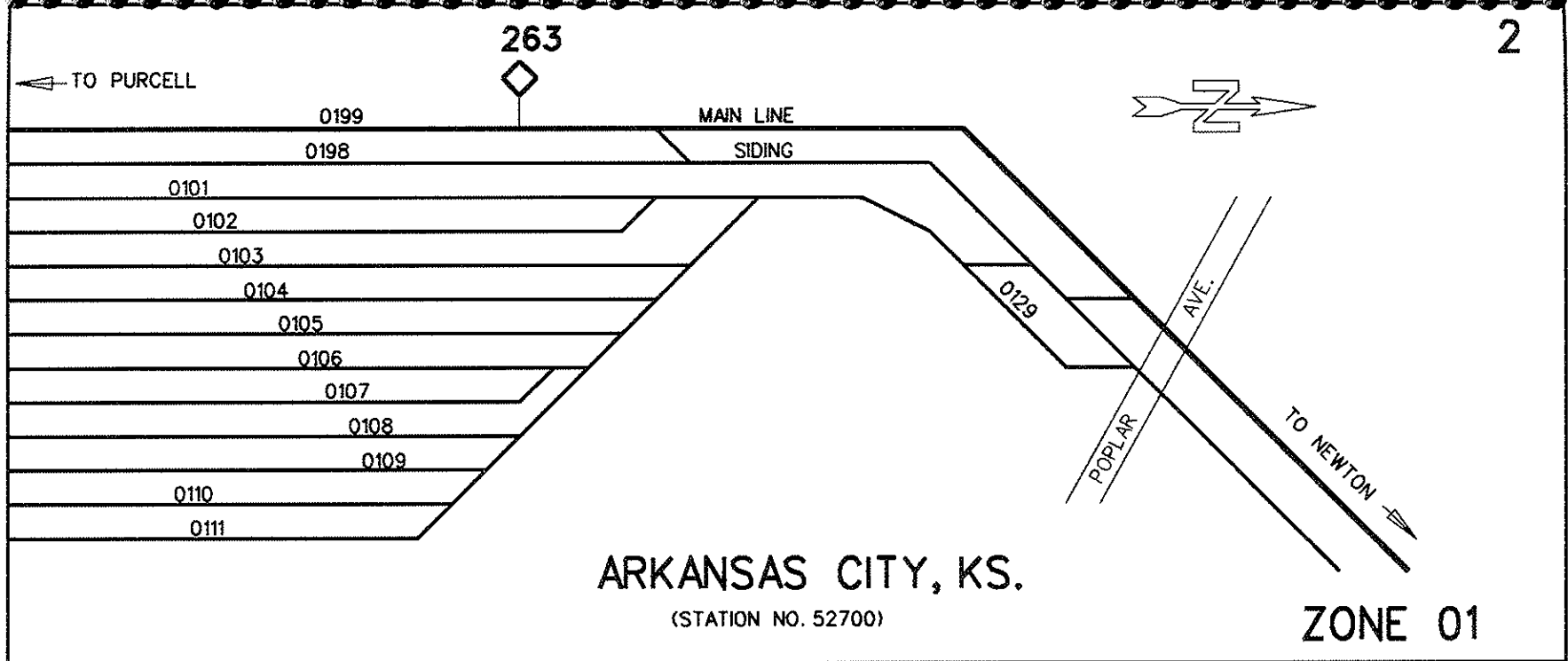

2

2

Zone 01 (Arkansas City 52700) Oklahoma Subdivision

- 01 11 00 Yard Track No. 11
- 01 12 00 Yard Track No. 12
- 01 13 00 Yard Track No. 13
- 01 14 00 Runaround Track

Page 3

C.E.NO. 12619-SK Engineering & Technology Development 4/92

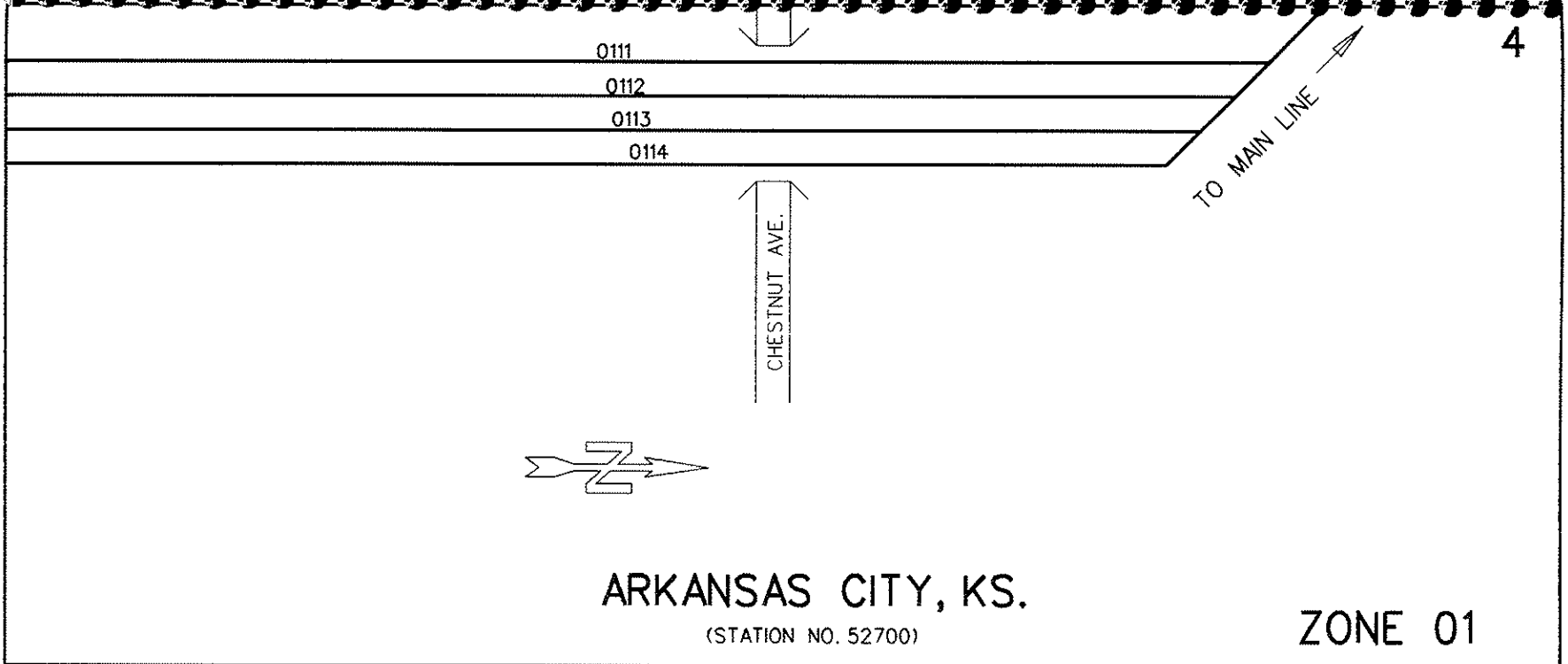

ARKANSAS CITY, KS.
(STATION NO. 52700)

ZONE 01

4

4

Zone 01 (Arkansas City 52700) Oklahoma Subdivision

01 41 00	Number 51 Track		01 44 04	Two Rivers Coop	(pit)
01 42 00	TOFC Track		01 44 05		(open)
01 42 01	TOFC Dock	(dock)	thru 06		
01 43 00	Team Track		01 44 07	Two Rivers Coop	(dock)
01 43 01	Team Track	(new dock)	01 44 20	Warehouse	(dock)
01 43 02	Team Track	(open)	01 44 30	Warehouse	(dock)
01 44 00	Two Rivers Coop Track		01 46 00	Short Pass Track	
01 44 01	Two Rivers Coop S Whse	(dock)	01 90 00	Old Pass Track	
thru 02			01 98 00	Siding	
01 44 03	Two Rivers Coop	(open)			

Page 5

C.E. NO. 11803-SK Engineering & Technology Development 4/92

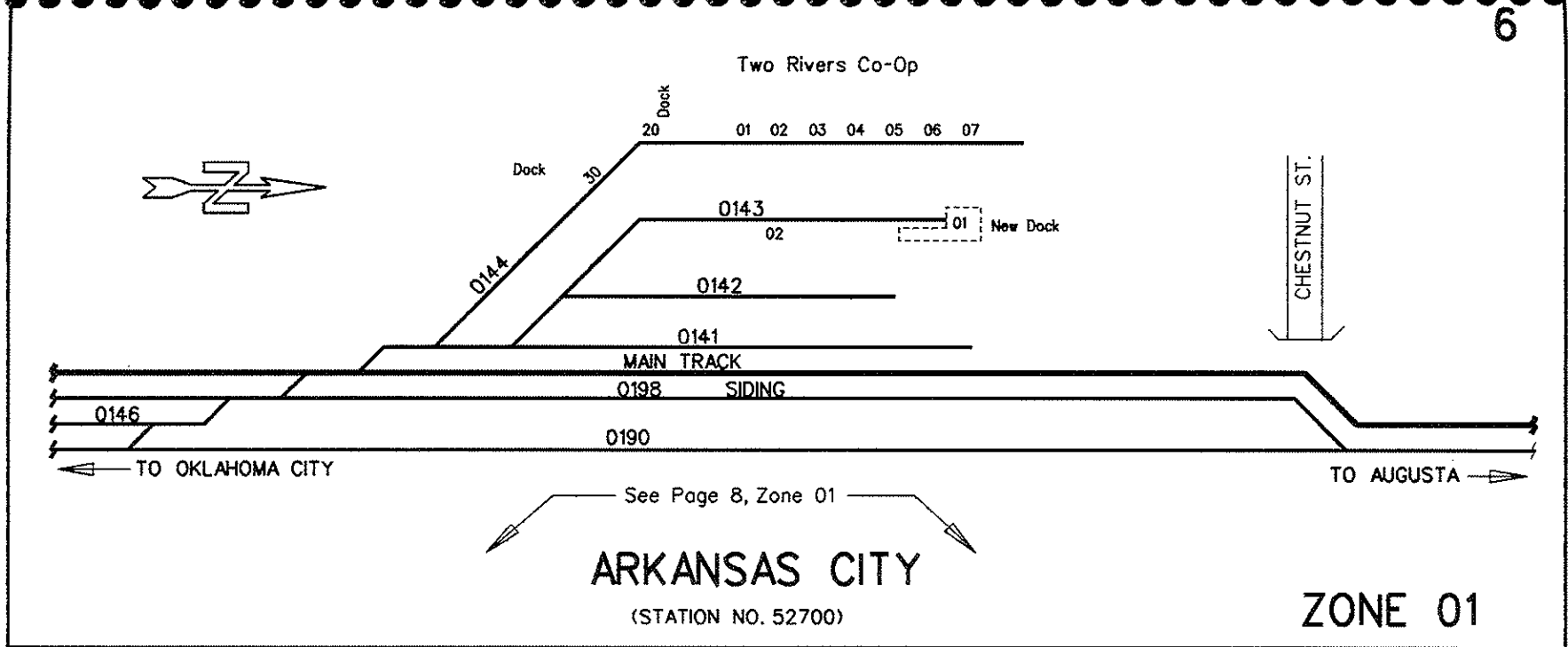

Zone 01 (Arkansas City 52700) Oklahoma Subdivision

01 01 00	Yard Track No 1	01 32 00	Lye Bye Track
01 02 00	Yard Track No 2	01 34 00	Interchange Track
01 03 00	Yard Track No 3	01 35 00	Middle Track
01 04 00	Yard Track No 4	01 36 00	Scale Track
01 05 00	Yard Track No 5	01 38 00	West Ice House Track
01 06 00	Yard Track No 6	01 46 00	Short Pass Track
01 07 00	Yard Track No 7	01 90 00	Old Pass Track
01 08 00	Yard Track No 8	01 98 00	Siding
01 09 00	Yard Track No 9	02 46 00	Roundhouse Lead Track
01 10 00	Yard Track No 10	03 06 00	Dixie Flr Lead Track

C.E. NO. 11803-SK Engineering & Technology Development 4/92

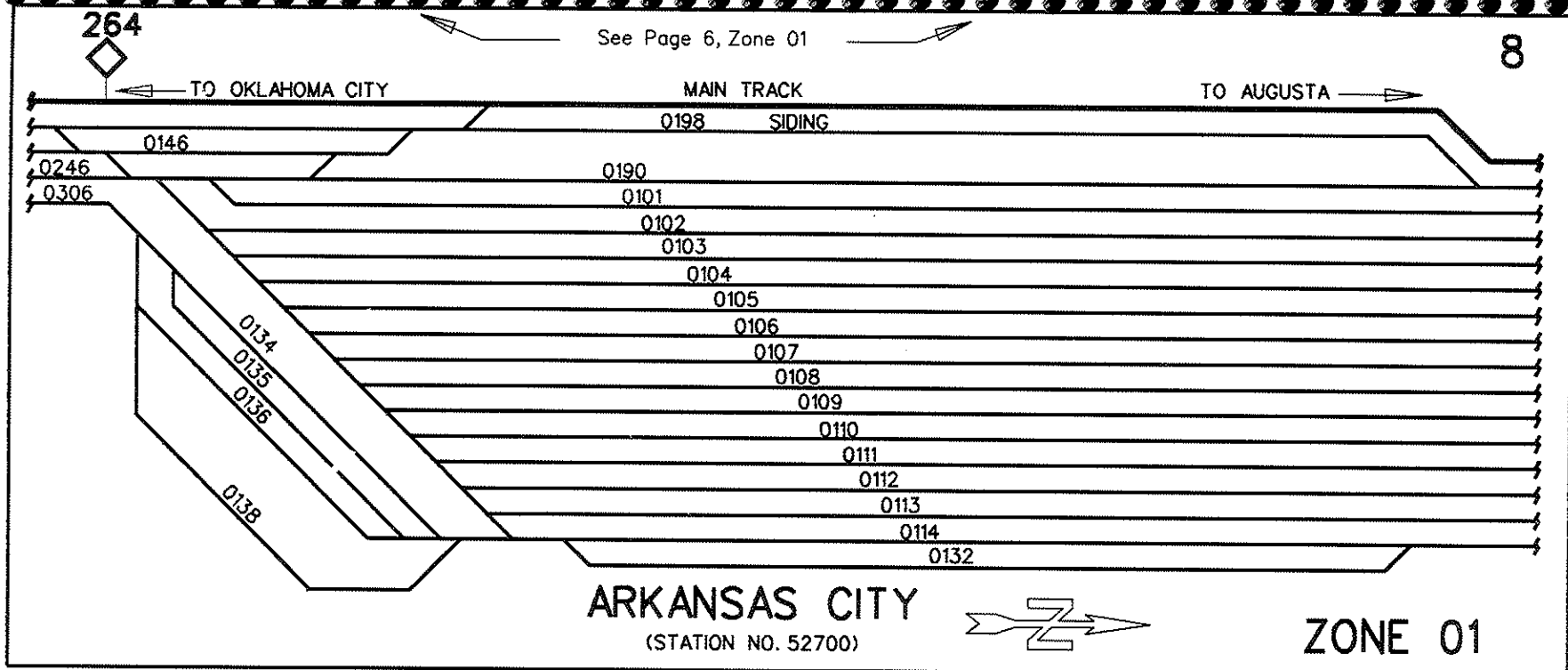

Zone 02 (Arkansas City 52700) Oklahoma Subdivision

- 02 11 00 West Track 2
- 02 12 00 Old Main Line
- 02 37 00 West Lead Track
- 02 39 00 Middle Lead Track
- 02 44 00 Storehouse Lead Track
- 02 45 00 Short Pass Track
- 02 46 00 Roundhouse Lead Track
- 02 98 00 Siding
- 02 99 00 Main Track
- 03 06 00 Dixie Flr Lead Track
- 03 10 00 ADM Milling Lead

Page 9

C.E. NO. 11803-SK Engineering & Technology Development 4/92

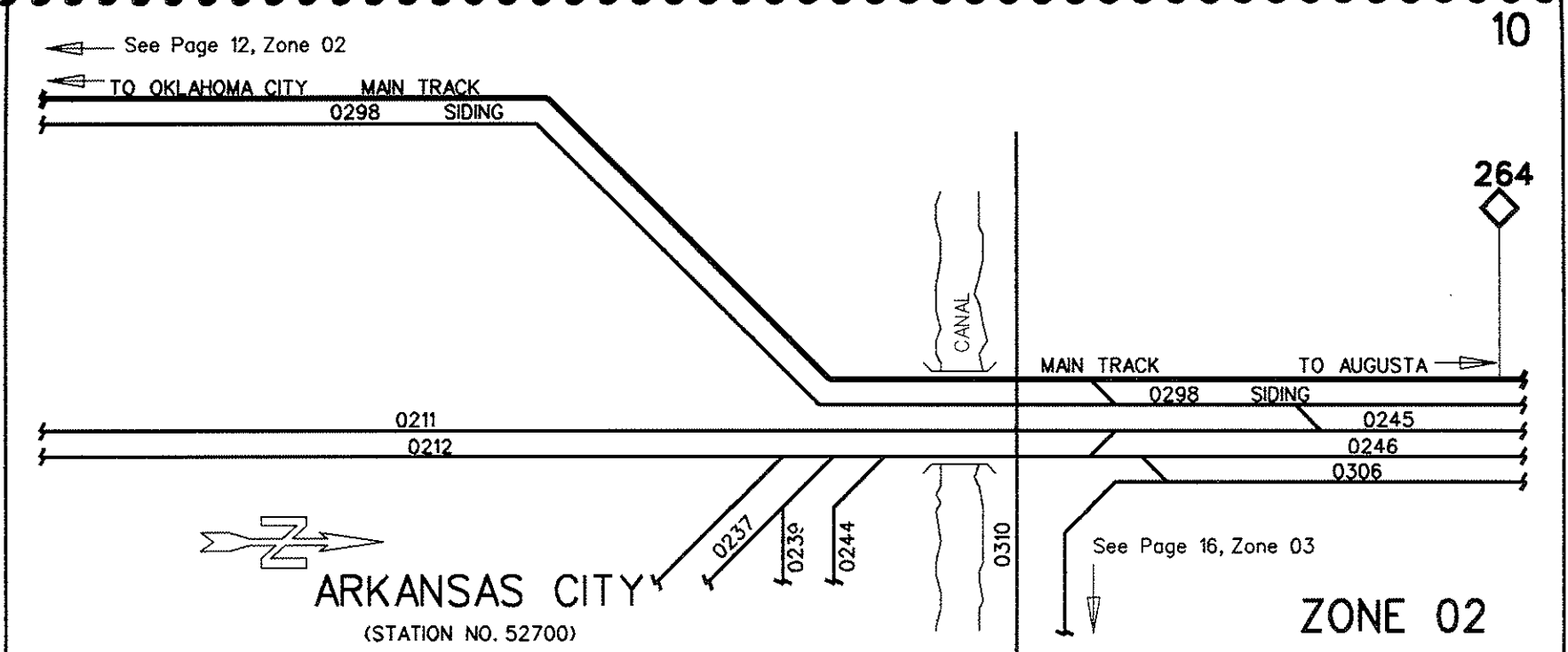

10

10

ZONE 02

Zone 02 (Arkansas City 52700) Oklahoma Subdivision

- 02 11 00 West Track 2
- 02 12 00 Old Main Line
- 02 19 00 Old Yard Track 16 (Coach)
- 02 50 00 South Lead Track
- 02 98 00 Siding
- 02 99 00 Main Track
- 04 01 00 Ark City Packing Lead

Page 11

C.E. NO. 11803-SK Engineering & Technology Development 4/92

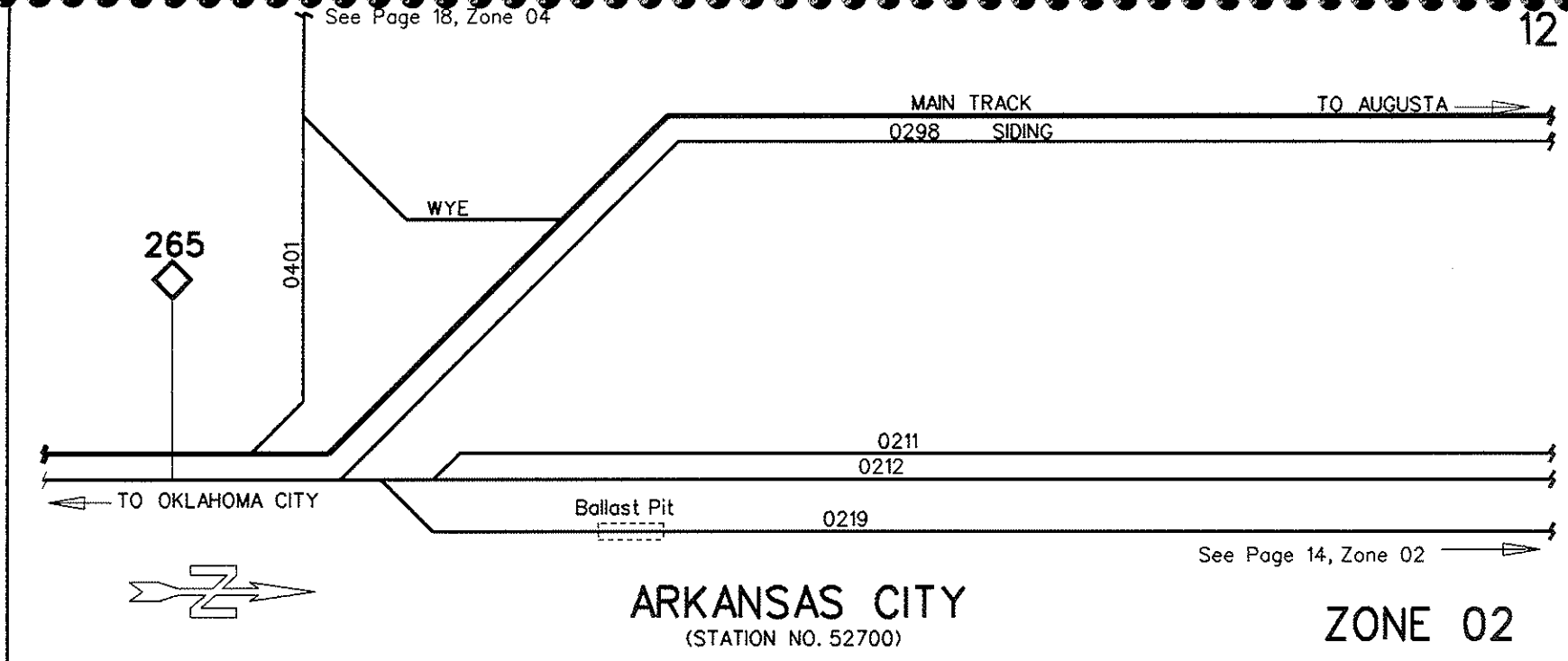

Zone 02 (Arkansas City 52700) Oklahoma Subdivision

- 02 12 00 Old Main Line
- 02 19 00 Old Yard Track 16 (Coach)
- 02 31 00 D S K Dock Track
- 02 44 00 Storehouse Lead Track

Page 13

C.E. NO. 11803-SK Engineering & Technology Development 4/92

14

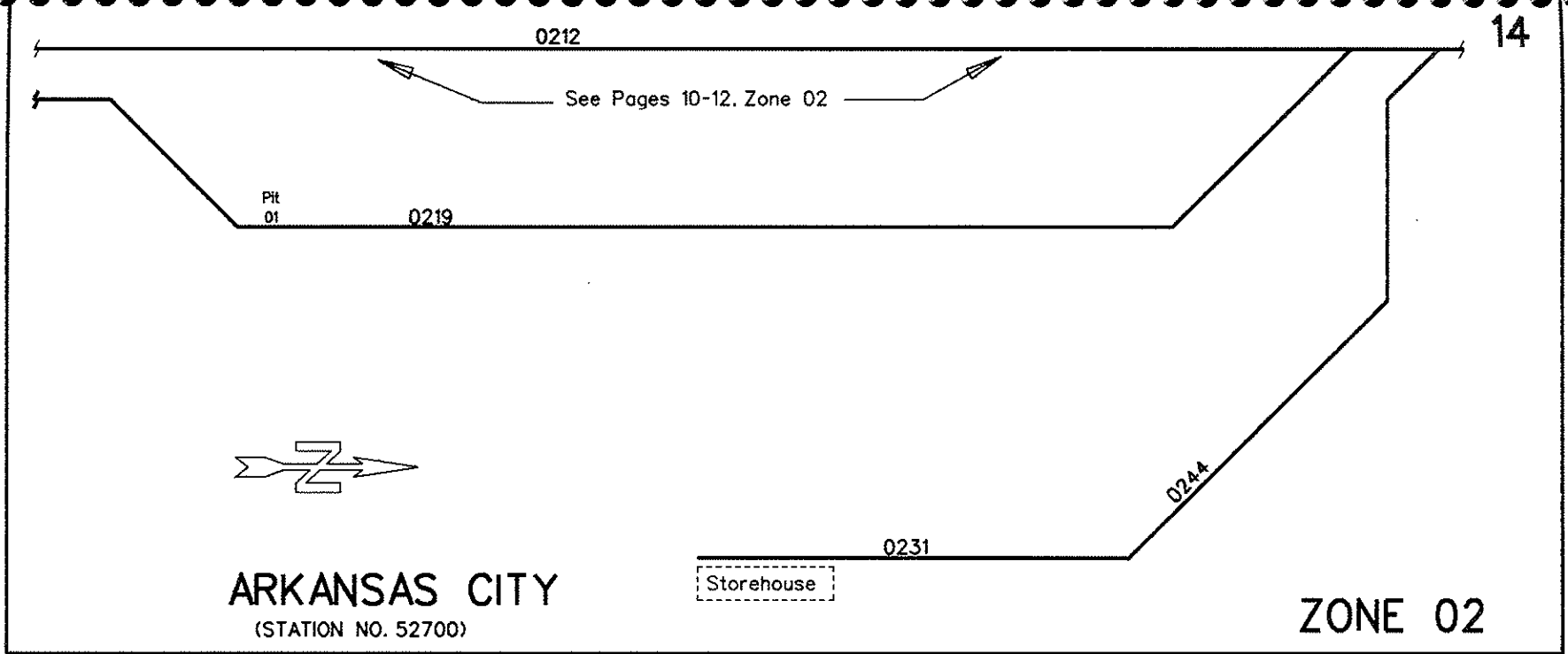

Zone 03 (Arkansas City 52700) A D M Milling

02 98 00	Siding		03 03 07	A D M Milling	(spout)
02 99 00	Main Track		thru 09		
03 01 00	A D M Milling Track 1		03 04 00	A D M Milling Track 4	
03 01 01	A D M Milling	(open)	03 04 01	A D M Milling (Storage)	
03 01 02	A D M Milling	(door)	thru 09		
thru 09			03 05 00	A D M Milling Trestle Track	
03 02 00	A D M Milling		03 05 01	A D M Milling	(open)
03 02 01	A D M Milling	(open)	thru 05		
thru 02			03 06 00	A D M Milling	
03 02 03	A D M Milling	(bridge)	03 07 00	Storage Lead	
thru 09			03 10 00	A D M Milling	
03 03 00	A D M Milling Track 3		03 11 00	M. P. ICD	
03 03 01	A D M Milling	(open)	03 12 00	M. P. ICD	
thru 06					

Page 15

C.E. NO. 11803-SK Engineering & Technology Development 4/92

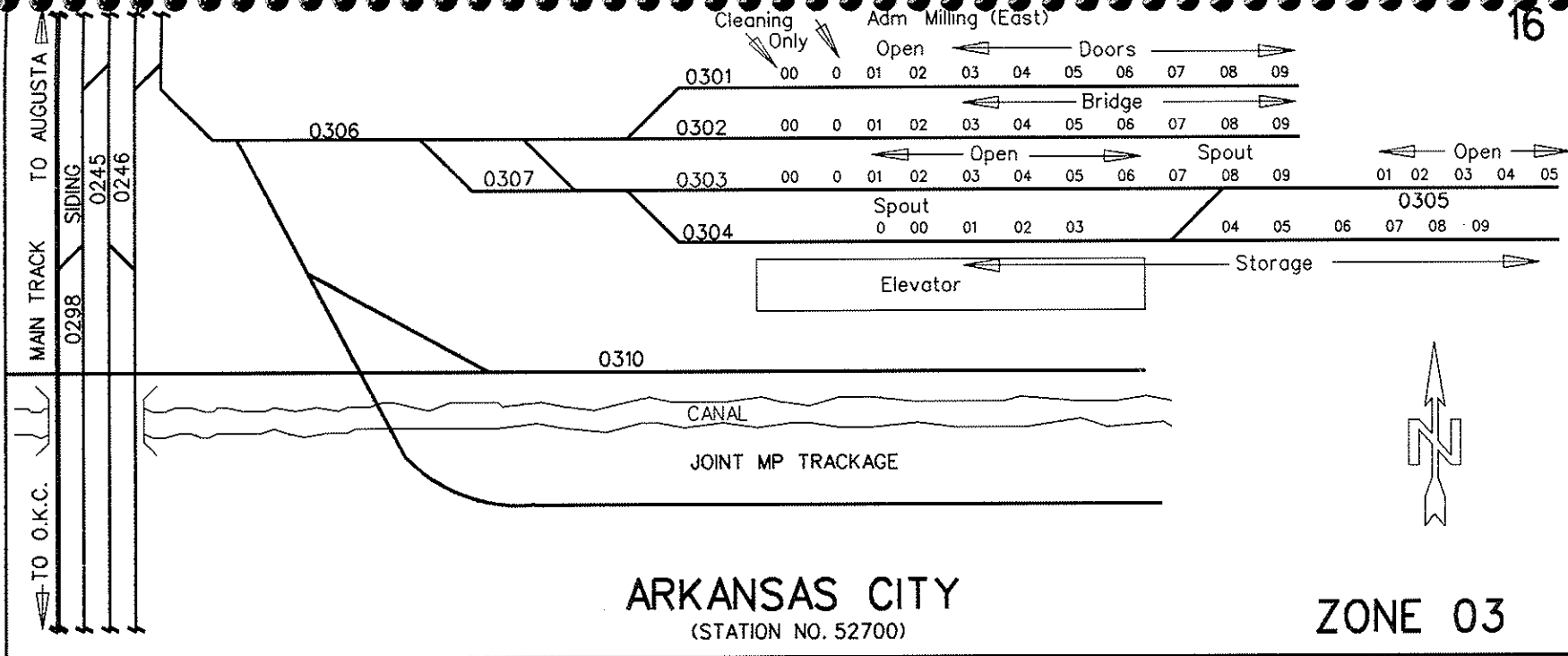

ARKANSAS CITY
(STATION NO. 52700)

ZONE 03

Zone 04 (Arkansas City 52700) Oklahoma Subdivision

02 98 00 Siding
02 99 00 Main Track
04 01 00 Ark City Packing Lead

Page 17

C.E. NO. 11803-SK Engineering & Technology Development 4/92

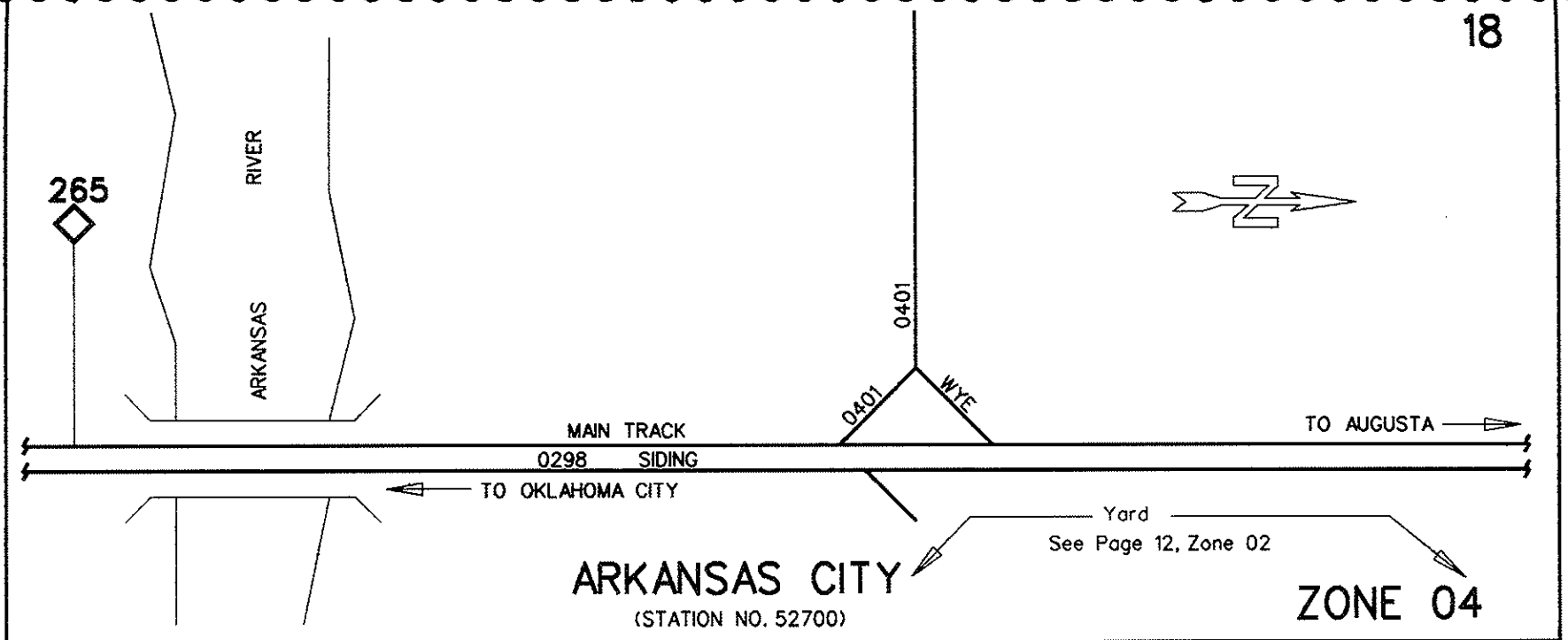

18

Zone 04 (Arkansas City 52700) Oklahoma Subdivision

04 05 00	Skyline Homes & Waldeck Agri	
04 05 01	Skyline Homes	(dock)
04 05 02	Waldeck Agrico Fert Service	(open)
04 06 00	Waldeck Agrico Fert Track	
04 06 01	Waldeck Agrico Fert Service	(open)
04 06 10		(door)
04 07 00	Waldeck Lead	

Page 19

C.E. NO. 12619-SK Engineering & Technology Development 4/92

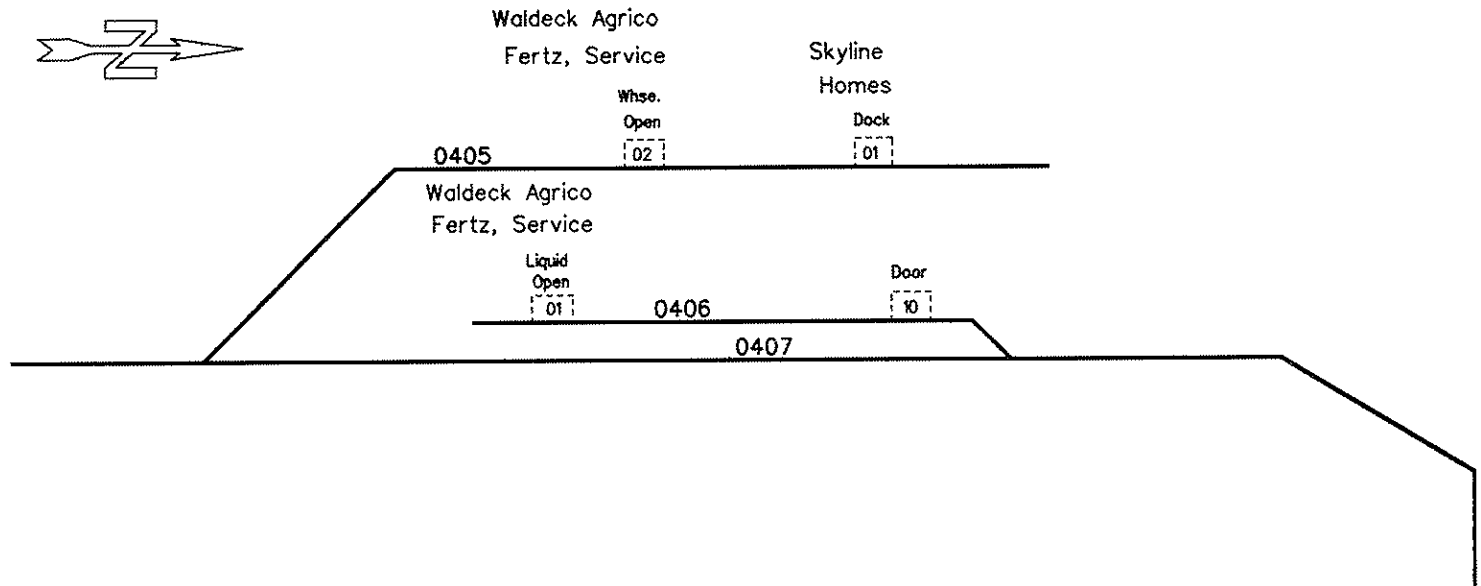

20

20

ARKANSAS CITY, KS.
(STATION NO. 52700)

ZONE 04

Zone 05 (Arkansas City 52700) Oklahoma Subdivision

- 02 98 00 Siding
- 02 99 00 Main Track
- 05 01 00 ADM Milling Track 1
- 05 05 00 ADM Milling Runaround

Page 21

C.E. NO. 12619-SK Engineering & Technology Development 4/92

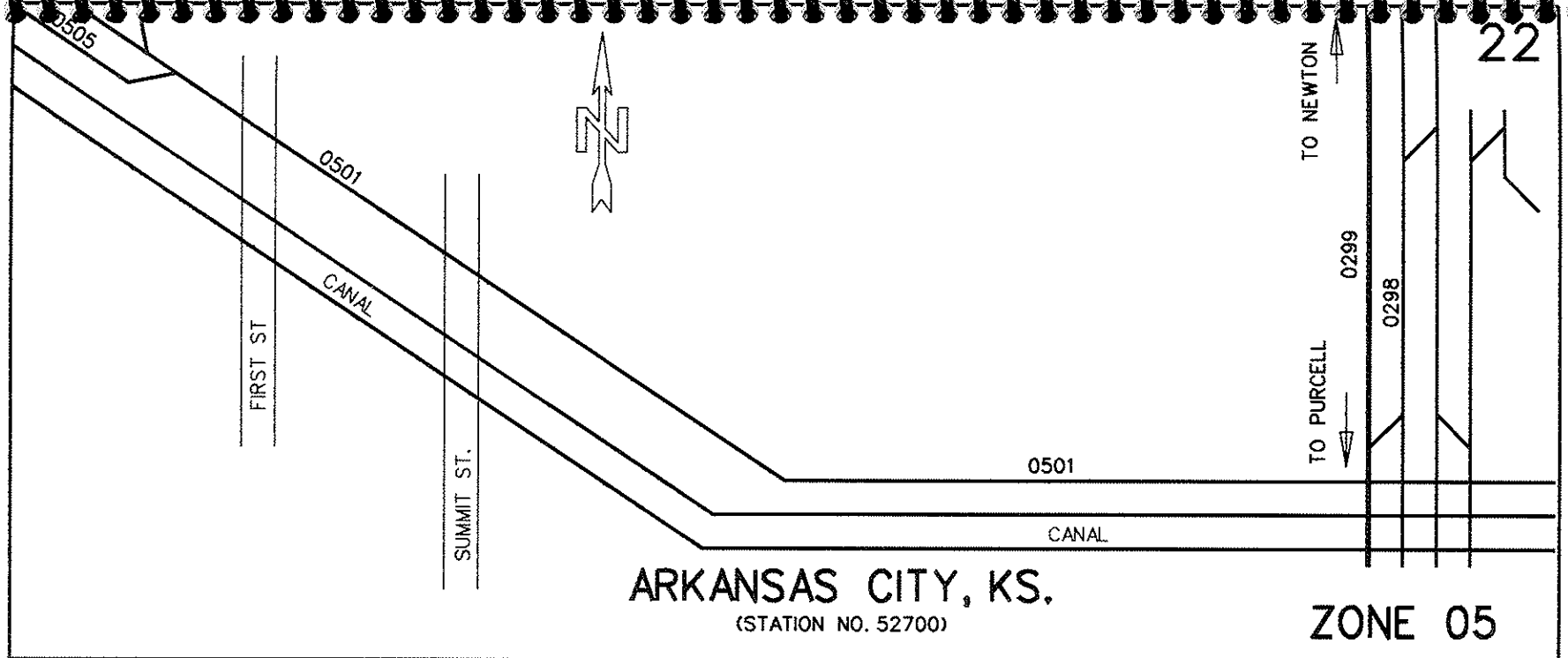

22

22

Zone 05 (Arkansas City 52700) Oklahoma Subdivision

05 01 00	A D M Milling Track 1		05 03 00	A D M Milling Track No 3	
05 01 01	A D M Milling	(o/h hose)	05 03 01	A D M Milling (sack ldg)	(dock)
thru 05			thru 04		
05 02 00	A D M Milling Track 2		05 04 00	A D M Milling Track No 4	
05 02 01	A D M Milling	(o/h hose)	05 04 01	A D M Milling	(u.t. auger)
thru 05			thru 09		
05 02 06	A D M Milling (sack ldg)	(dock)	05 05 00	A D M Milling Runaround Track	
thru 07					

C.E. NO. 12619-SK Engineering & Technology Development 4/92

24

24

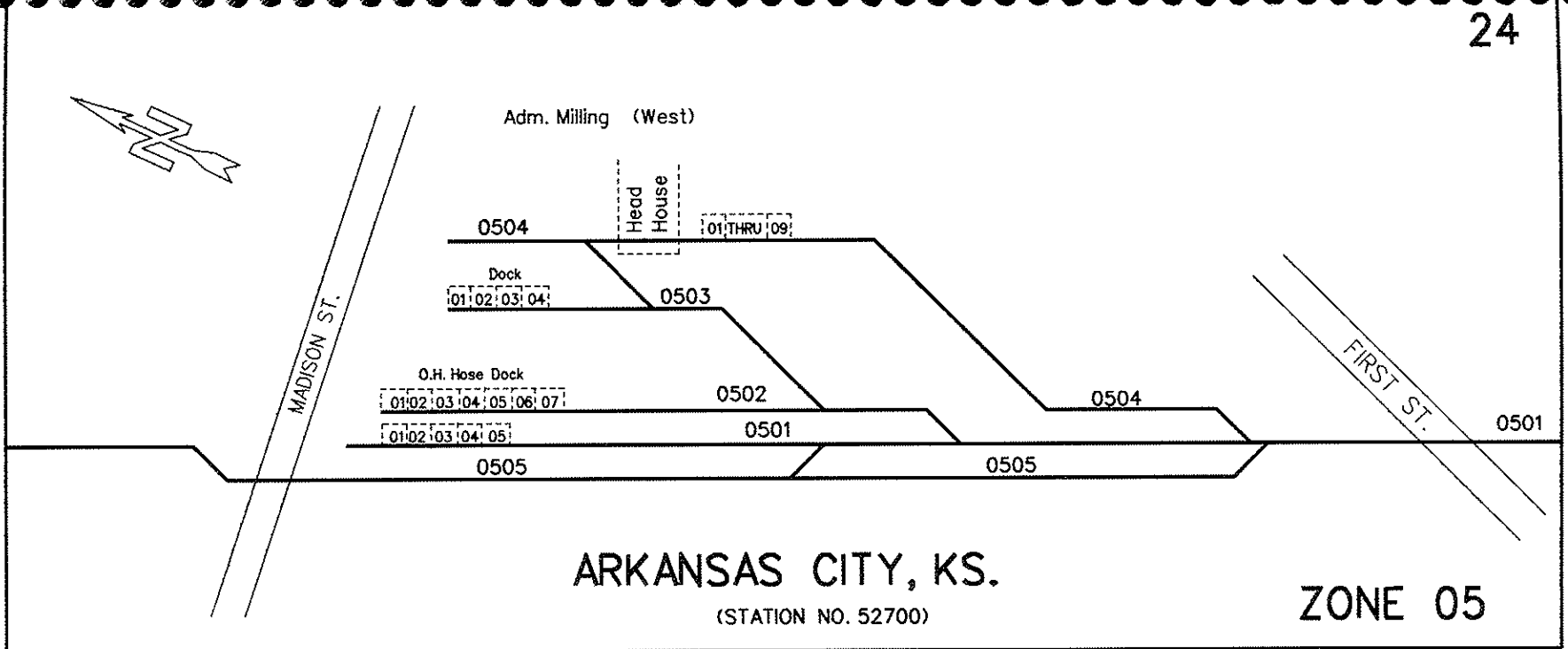

Zone 05 (Arkansas City 52700) Oklahoma Subdivision

04 07 00 Waldeck Lead
05 05 00 ADM Milling Runaround Track

Page 25

C.E. NO. 12619-SK Engineering & Technology Development 4/92

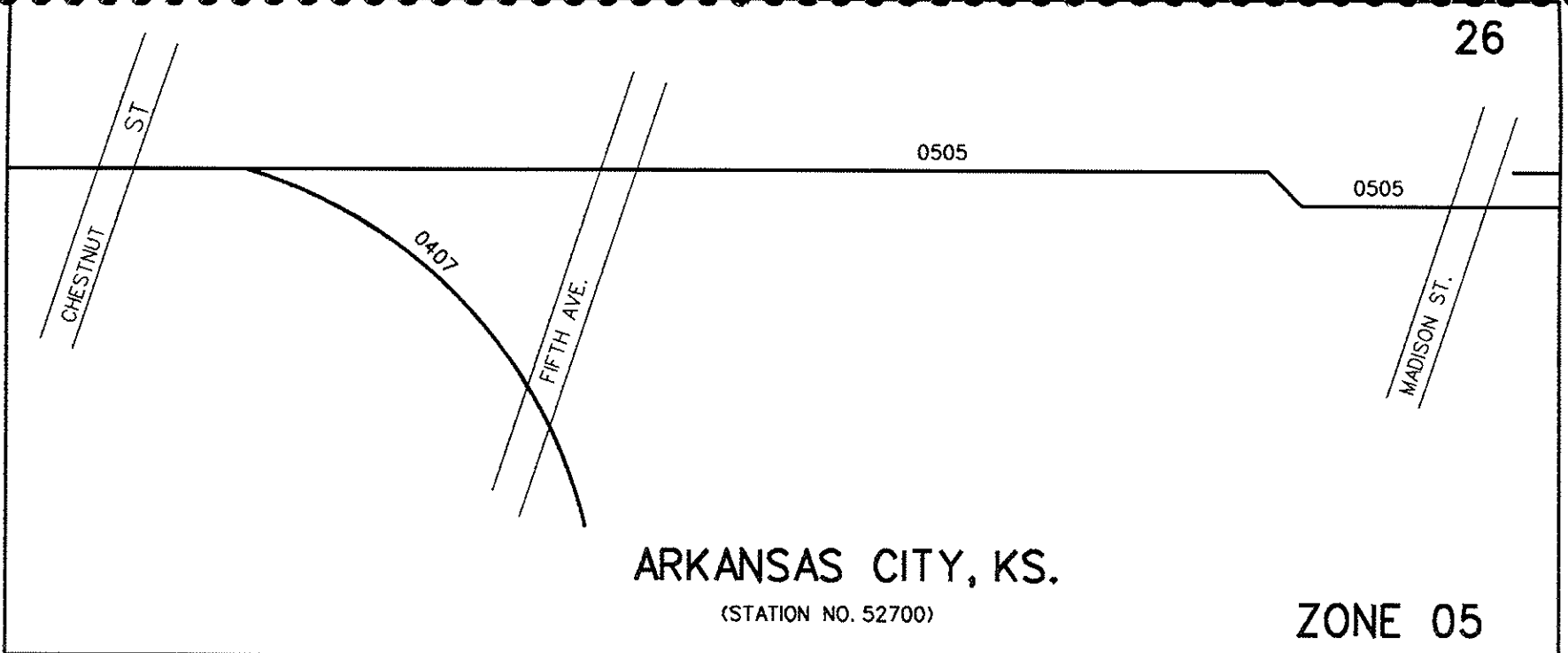

26

Zone 17 (Newkirk 52680) Oklahoma Subdivision

17 01 00	Elevator Track	
17 01 01	Farmers Coop	(spout)
thru 02		
17 01 03	Farmers Coop	(riser)
17 02 00	House Track	
17 02 01	Team Track Patrons	(open)
thru 03		
17 98 00	Siding	
17 99 00	Main Track	

Page 27

C.E. NO. 11803-SK Engineering & Technology Development 4/92

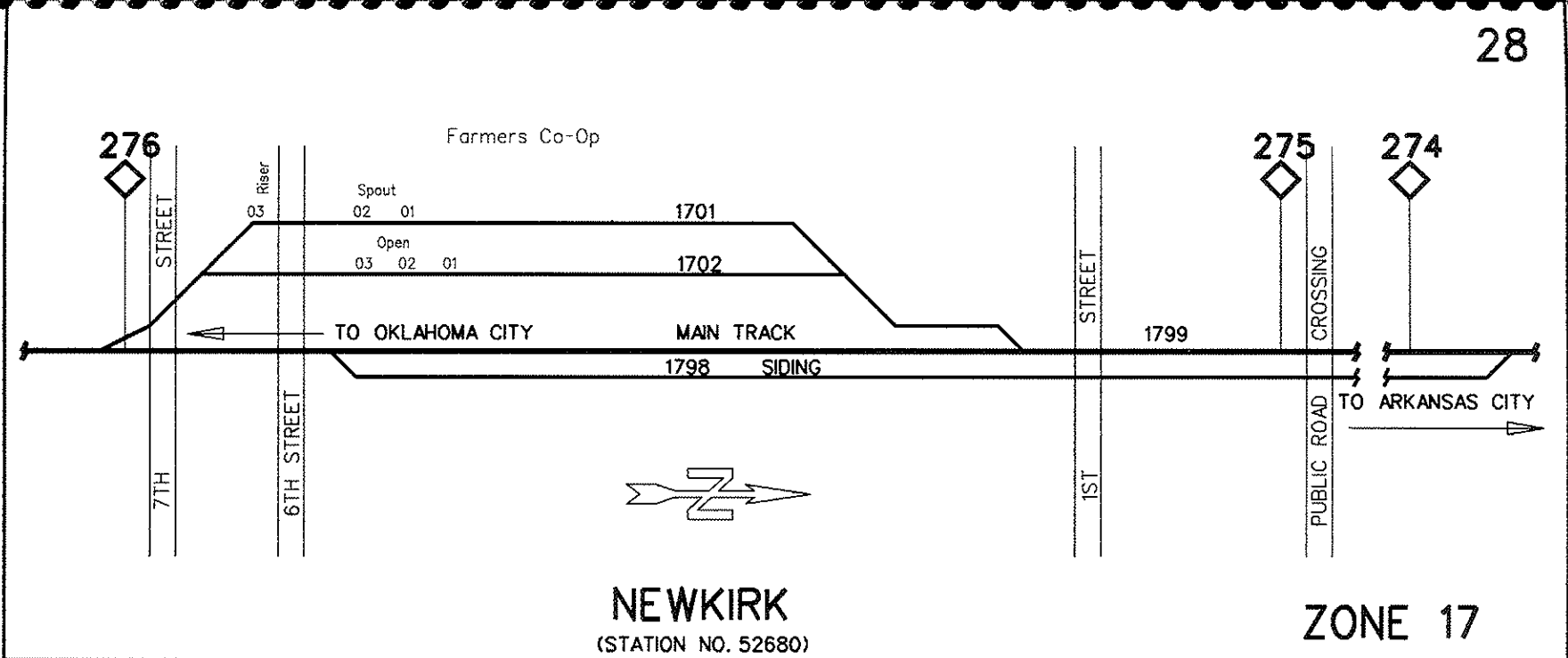

28

28

Zone 17 (Kildare 52670) Oklahoma Subdivision

17 06 00	Coop Spur	
17 06 01	Farmers Coop	(riser)
17 06 02	Farmers Coop	(auger)
17 06 03	Farmers Coop	(spout)
17 99 00	Main Track	

Page 29

C.E. NO. 11803-SK Engineering & Technology Development 4/92

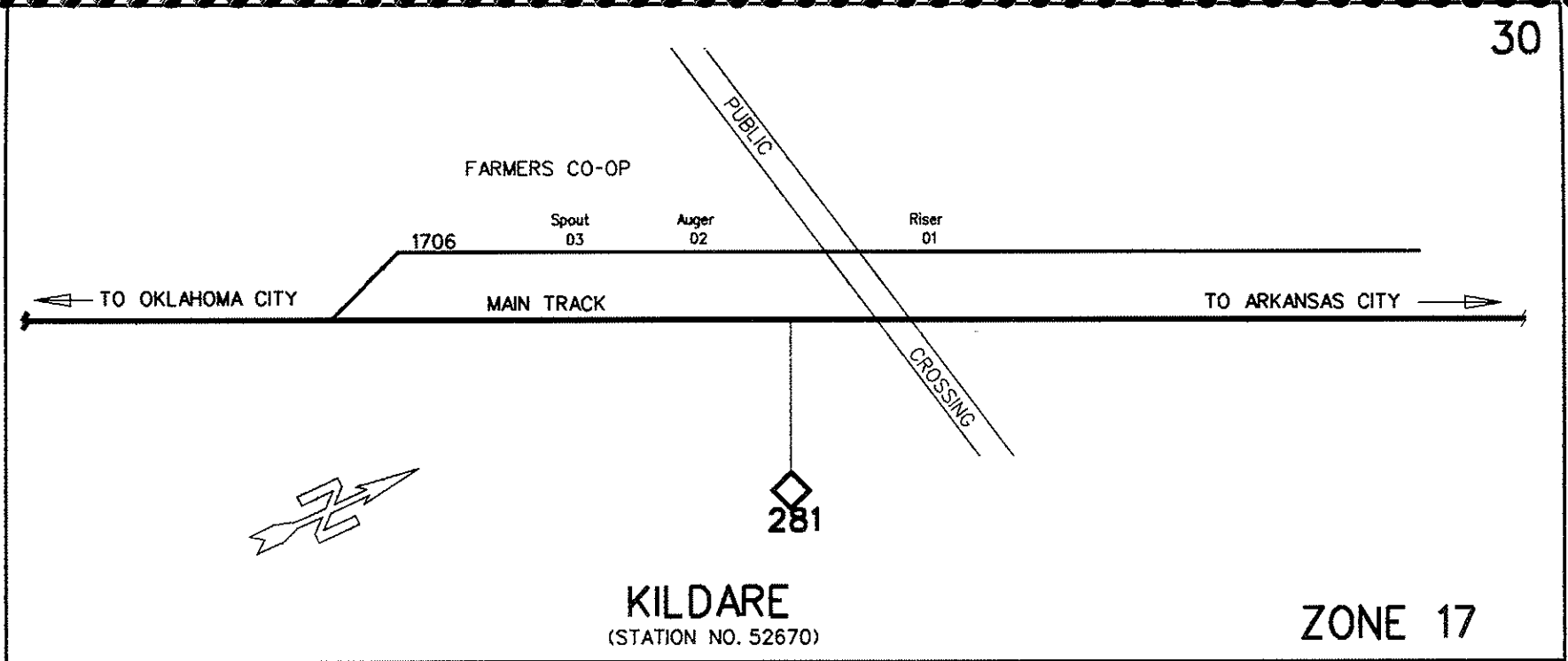

30

30

KILDARE
(STATION NO. 52670)

ZONE 17

Zone 21 (Ponca City 52300) Oklahoma Subdivision

21 02 00	Yard Track No 1	21 13 00	Yard Track No 13
21 02 00	Yard Track No 2	21 14 00	Yard Track No 14
21 03 00	Yard Track No 3	21 15 00	Yard Tail Track
21 04 00	Yard Track No 4	21 16 00	West Roundhouse Track
21 05 00	Yard Track No 5	21 17 00	East Roundhouse Track
21 06 00	Yard Track No 6	21 18 00	Electric Ice Spur
21 07 00	Yard Track No 7	21 99 00	Main Track
21 08 00	Yard Track No 8	23 06 00	C & P No 1
21 09 00	Yard Track No 9	23 07 00	C & P No 2
21 10 00	Yard Track No 10	23 07 01	C & P (door)
21 11 00	Yard Track No 11	23 30 00	Cities Service Lead No 1
21 12 00	Yard Track No 12		

Page 31

C.E. NO. 11803-SK Engineering & Technology Development 4/92

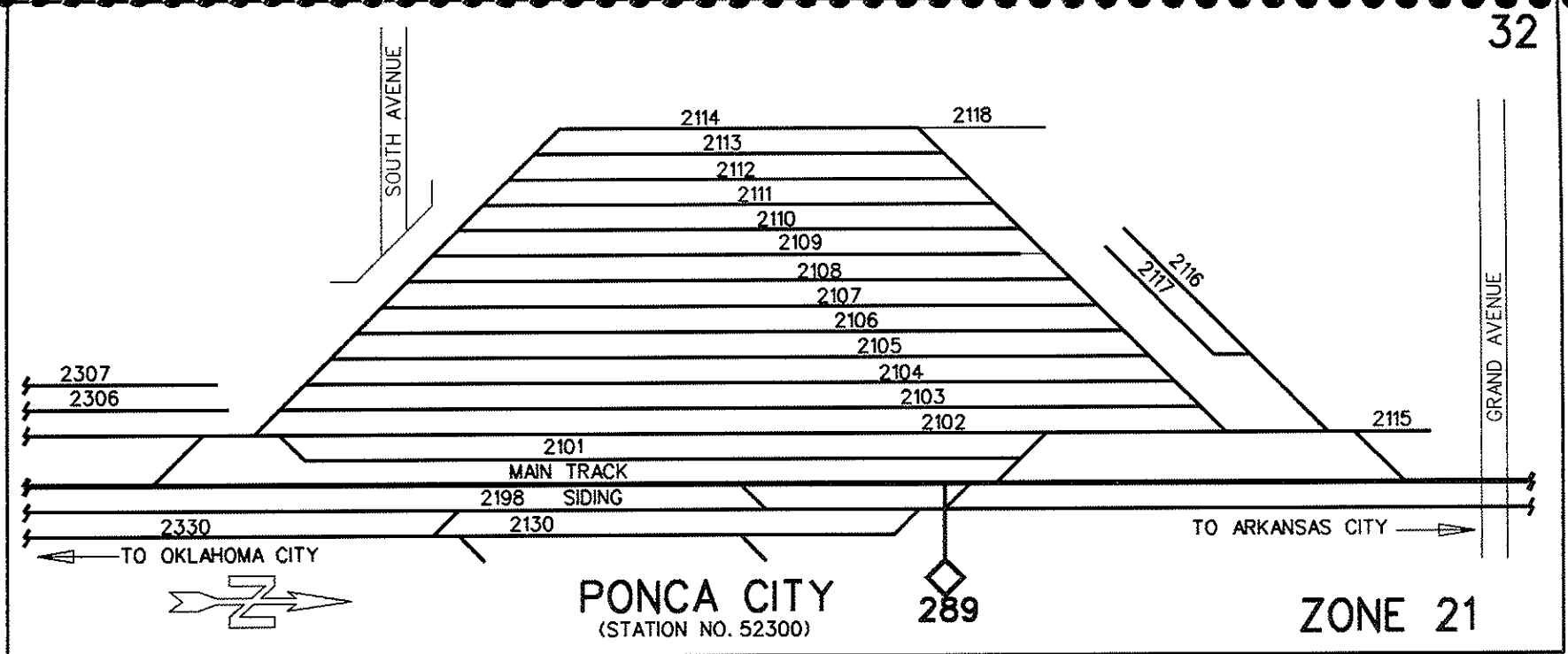

32

32

Zone 21 (Ponca City 52300) Oklahoma Subdivision

- 21 01 00 Yard Track No 1
- 21 30 00 House Lead
- 21 31 00 West House
- 21 32 00 Middle House Track
- 21 34 00 South Leg of Back Lead
- 21 35 00 Long Team
- 21 38 00 Tofc Track
- 21 38 01 Tofc Dock (dock)
- 21 98 00 Siding
- 21 99 00 Main Track

Page 33

C.E. NO. 11803-SK Engineering & Technology Development 4/92

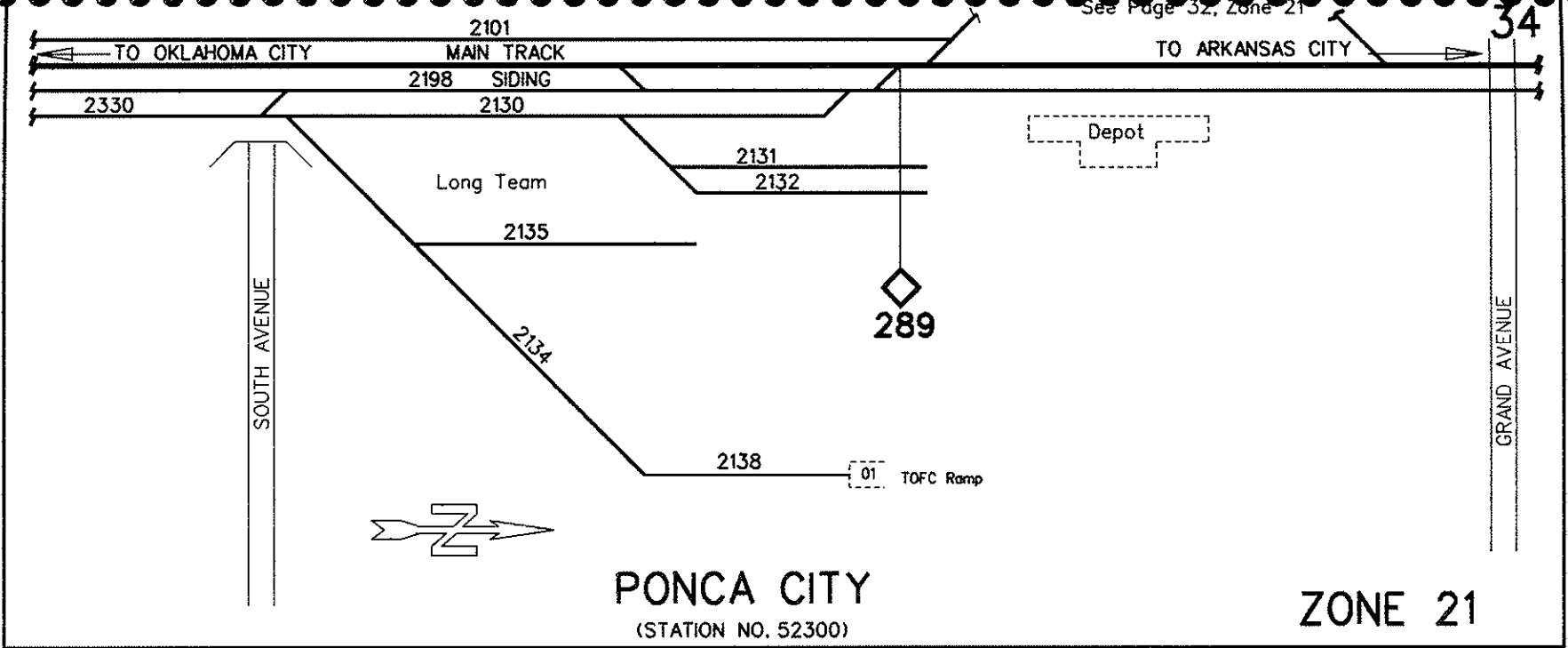

34

34

Zone 22 (Ponca City 52300) Oklahoma Subdivision

22 01 00	Phillips Petroleum		22 08 01	Ponca Iron Co	(open)
22 01 00	Phillips Petroleum	(open)	thru 02		
thru 02			22 09 00	Skaggs Alpha Beta Inc	
22 03 00	South Leg of WYE (Ponca City Ind Spur)		22 10 00	Pioneer Liquor Spur	
22 05 00	Boersma Beer		22 10 01	Pioneer Liquor	
22 05 01	Boersma Beer Co	(door)	22 21 00	Jeffrie Beer Spur	
thru 02			22 21 01	Jeffrie Beer Co	
22 06 00	North Leg of Wye		22 98 00	Siding	
22 07 00	Independent Lumber Spur		22 99 00	Main Track	
22 08 00	Ponca Iron				

C.E. NO. 11803-SK Engineering & Technology Development 4/92

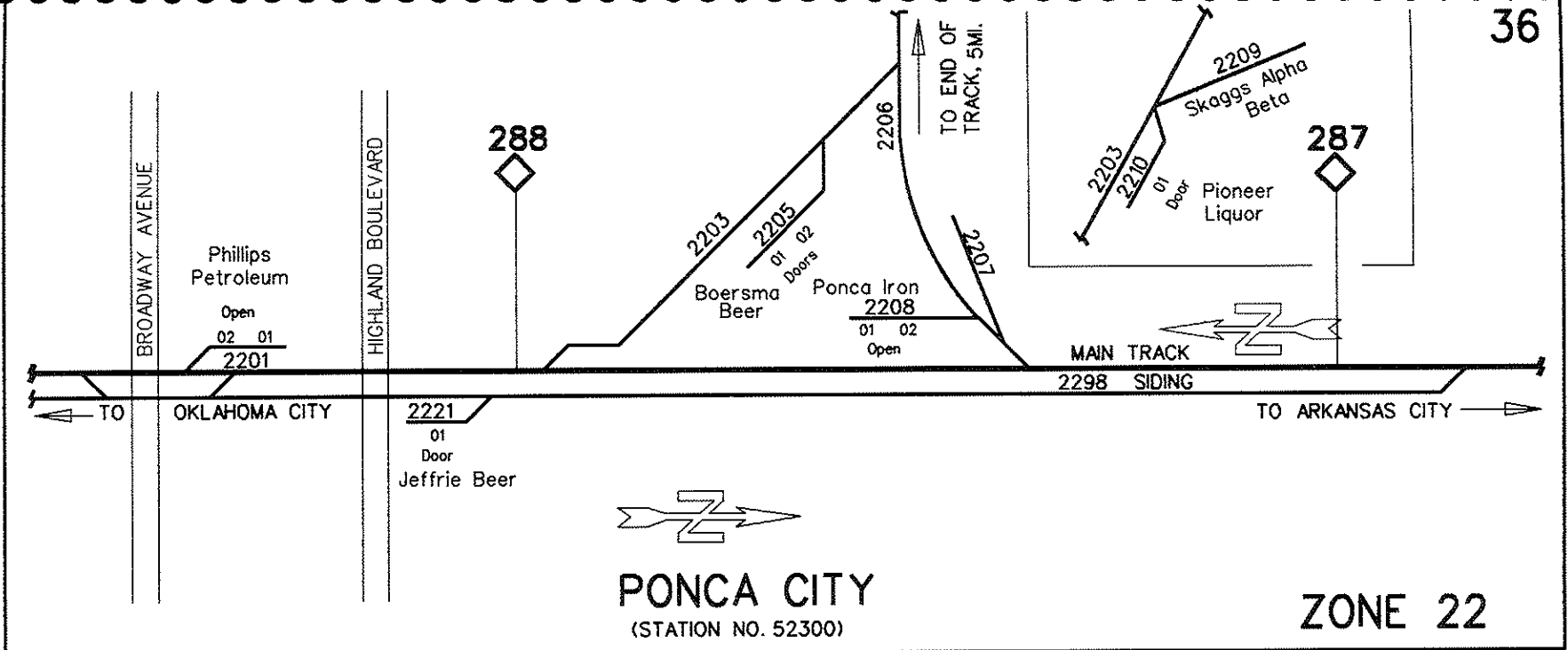

Zone 23 (Ponca City 52300) Oklahoma Subdivision

23 01 00	South No 1		23 08 03	Conoco	(dock)	23 14 00	Conoco Lite Oil Track No 3	
23 02 00	South No 2		23 08 04	Conoco	(door)	23 14 01	Conoco Lite Oil	(rack)
23 03 00	South No 3		thru 09			thru 09		
23 04 00	South No 4		23 09 00	Conoco East Lube Track		23 15 00	Conoco Lite Oil Track No 4	
23 05 00	South No 5		23 09 01	Conoco Grease	(rack)	23 15 01	Conoco Lite Oil	(rack)
23 05 01	Conoco	(door)	thru 08			thru 09		
23 06 00	C & P No 1 Track		23 10 00	Conoco West Lube Track		23 16 00	Conoco Lite Oil Track No 5	
23 06 01	C & P	(rack)	23 10 01	Conoco Grease		23 16 01	Conoco Lite Oil	(rack)
23 06 02	C & P Pocket Spot	(hose)	thru 08			thru 02		
thru 03			23 11 00	Conoco Grease Spur		23 30 00	Cities Service Lead No 1	
23 07 00	C & P No. 2 Track		23 11 01	Conoco Grease	(open)	23 31 00	High Pressure No 2	
23 07 01	C & P		thru 03			23 32 00	High Pressure No 1	
23 08 00	Conoco Grease Plant E Trk		23 12 00	Conoco Lite Oil Trk No 1		23 34 00	Cities Service Lead No 2	
23 08 01	Conoco (clay Chute)	(door)	thru 10			23 36 00	Coker Track	
23 08 02	Conoco (lax spot)	(door)	23 13 00	Conoco Lite Oil Trk No 2		23 36 01	Coker	(o.h. chute)
			23 13 01	Conoco Lite Oil	(rack)	23 99 00	Main Track	
			thru 10					

C.E. NO. 11803-SK Engineering & Technology Development 4/92

38

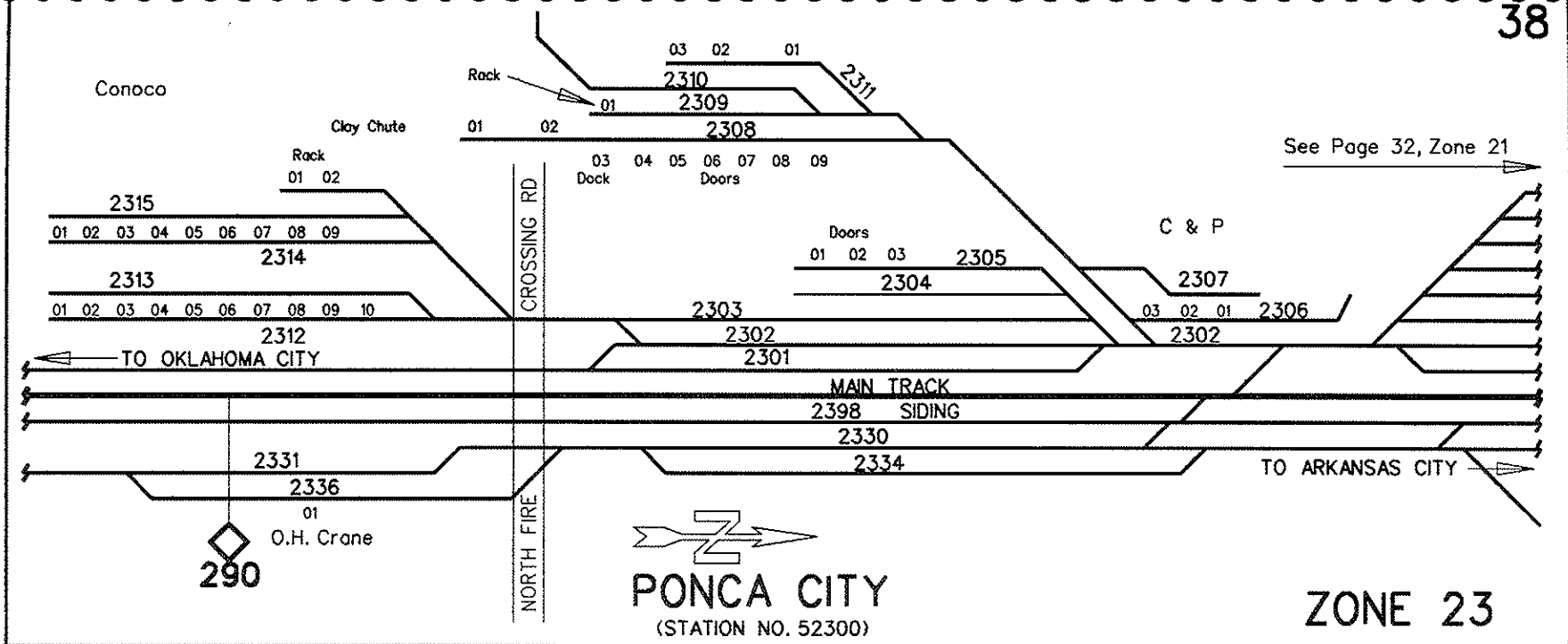

PONCA CITY
 (STATION NO. 52300)

ZONE 23

Zone 24 (Ponca City 52300) Oklahoma Subdivision

23 01 00	South No 1	
23 32 00	High Pressure No 1	
24 01 00	Straight Rail	
24 02 00	Ethyl Spur	
24 02 01	Ethyl Storage	(open)
thru 04		
24 03 00	Ethyl Spur Side Track	
24 03 01	Ethyl	(rack)
24 26 00	Butylox Lead	
24 27 00	Butylox Track	
24 27 01	Butylox	(open)
thru 04		
24 28 00	Butylox Storage	
24 98 00	Siding	
24 99 00	Main Track	

Page 39

C.E. NO. 11803-SK Engineering & Technology Development 4/92

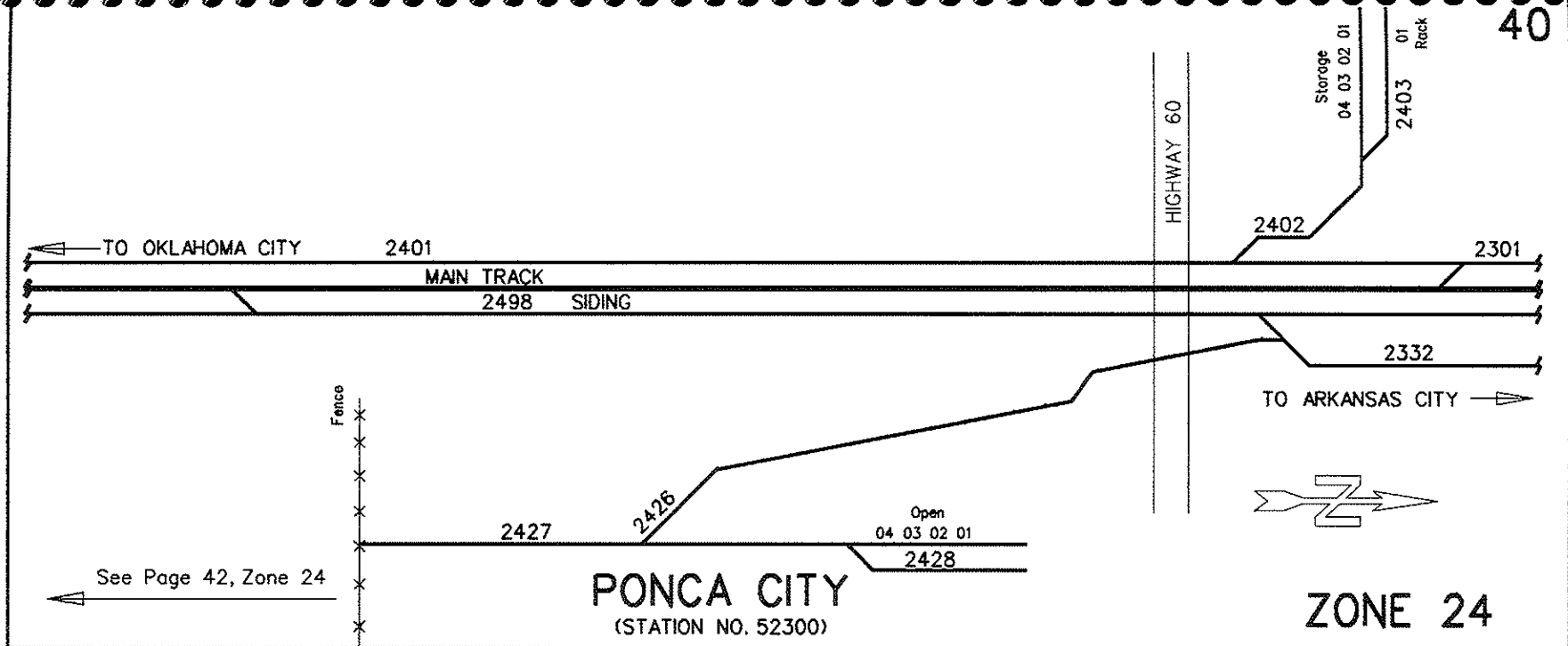

Zone 24 (Ponca City 52300) Oklahoma Subdivision

24 01 00	Straight Rail	
24 30 00	Chemical Spur	
24 30 01	Conoco	(acid Spot)
24 31 00	Conoco Gas Storage Spur	
24 31 01	Conoco Propane Unldg	(rack)
thru 04		
24 32 00	Conoco Gas Storage Spur	
24 32 01	Conoco Propane Unldg	(rack)
thru 04		
24 33 00	Conoco Gas Storage Spur	
24 98 00	Siding	
24 99 00	Main Track	
25 01 00	Straight Rail	
25 99 00	Main Track	
26 98 00	White Eagle Siding	

Page 41

C.E. NO. 11803-SK Engineering & Technology Development 4/92

42

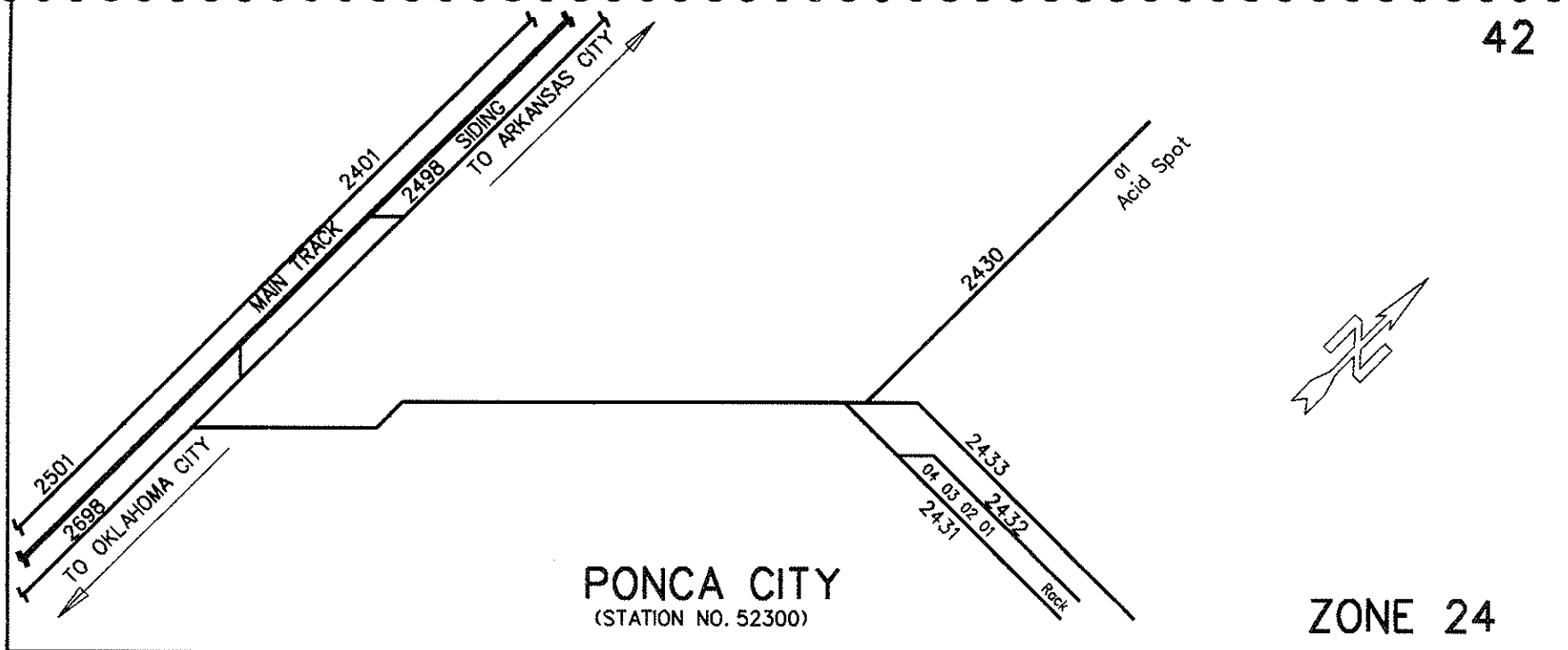

42

Zone 25 (Ponca City 52300) Oklahoma Subdivision

25 01 00	Straight Rail	25 22 00	Carbon Plant No 2
25 02 00	Storage Track	25 22 01	Continental Carbon Black (chute)
25 03 00	Storage Track	thru 13	
25 20 00	Carbon Plant Lead	25 99 00	Main Track
25 21 00	Carbon Plant No 1	26 98 00	White Eagle Siding
25 21 01	Continental Carbon Black (chute)		
thru 16			
25 21 17	(outside gate spot)		

Note: Spots 9 and 10 are across drawbridge, if request made by Witco to spot cas at this location, it is okay to block drawbridge.

C.E.NO.11803-SK Engineering & Technology Development 4/92

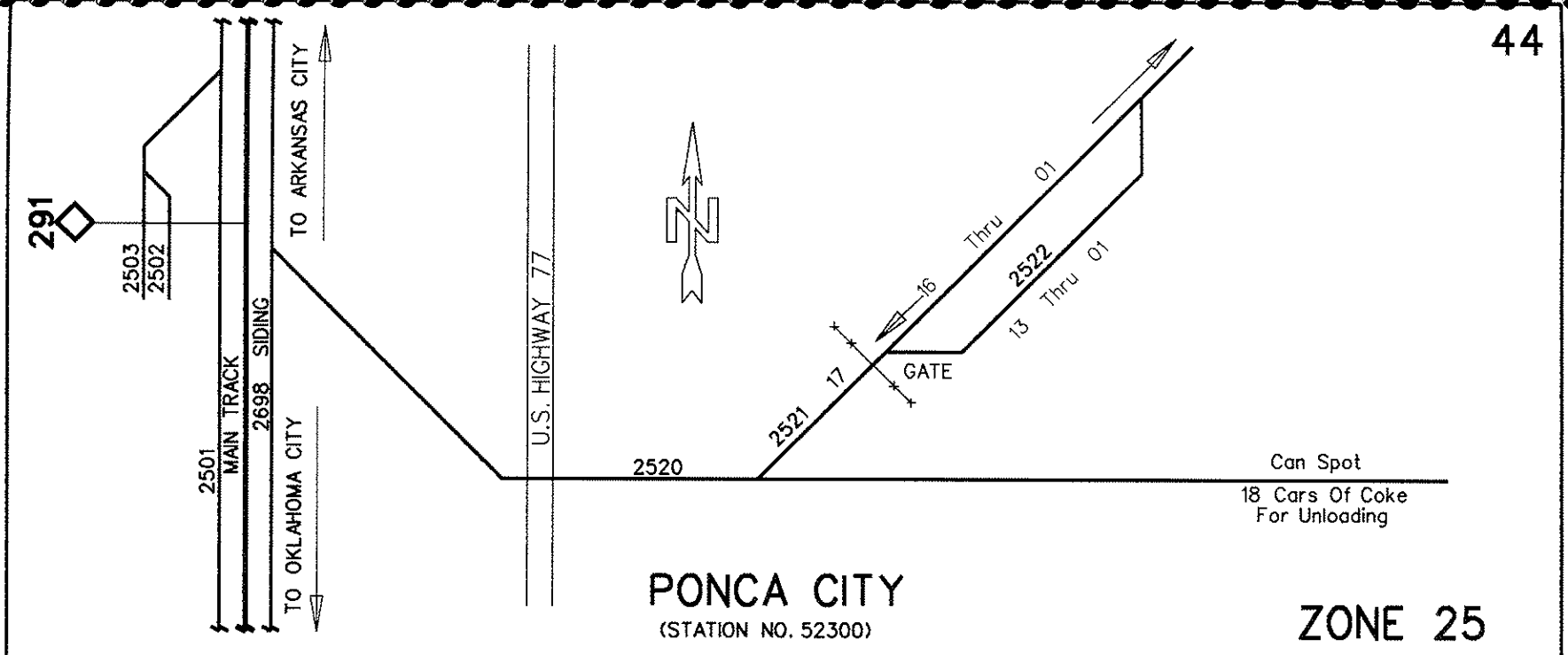

ZONE 25

PONCA CITY
(STATION NO. 52300)

Can Spot
18 Cars Of Coke
For Unloading

Zone 26 (Ponca City 52300) Oklahoma Subdivision

26 01 00	South Storage Track No 1
26 02 00	South Storage Track No 2
26 03 00	South Storage Track No 3
26 20 00	Duffic Spur
26 98 00	White Eagle Siding
26 99 00	Main Track

Page 45

46

C.E.NO.11803-SK Engineering & Technology Development 4/92

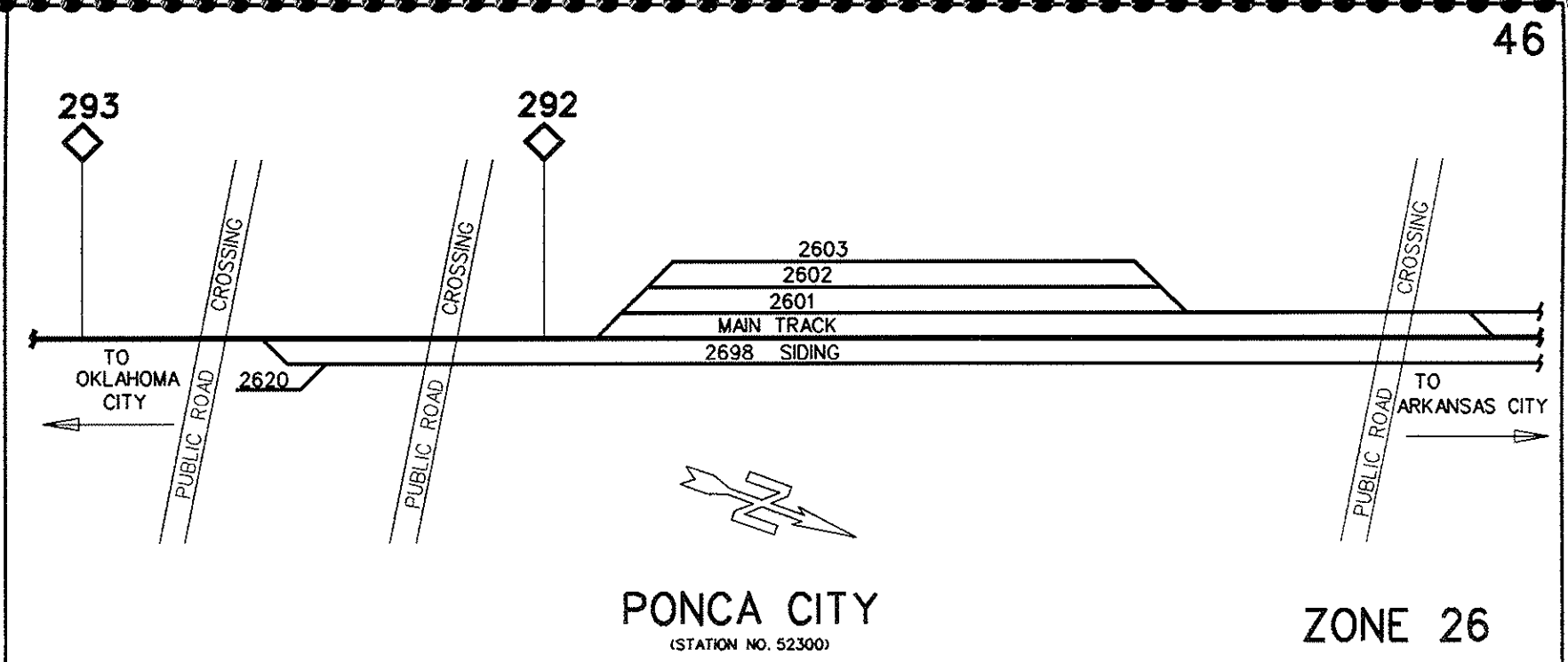

46

PONCA CITY
(STATION NO. 52300)

ZONE 26

Zone (Marland 52290) Oklahoma Subdivision

27 01 00	Bliss Coop		27 02 00	House Track	
27 01 01	Bliss Coop	(spout)	27 02 01	Team Track Patrons	(open)
27 01 02	Bliss Coop	(open)	27 02 02	Depot	(dock)
27 01 03	Bliss Coop	(auger)	27 02 03	House	(open)
27 01 04	Bliss Coop	(door)	27 99 00	Main Track	

Note: South covered hopper spotted for loading must be placed at spot 01 with the remaining cars extending north. A cut must be made at the road crossing.

C.E. NO. 11803-SK Engineering & Technology Development 4/92

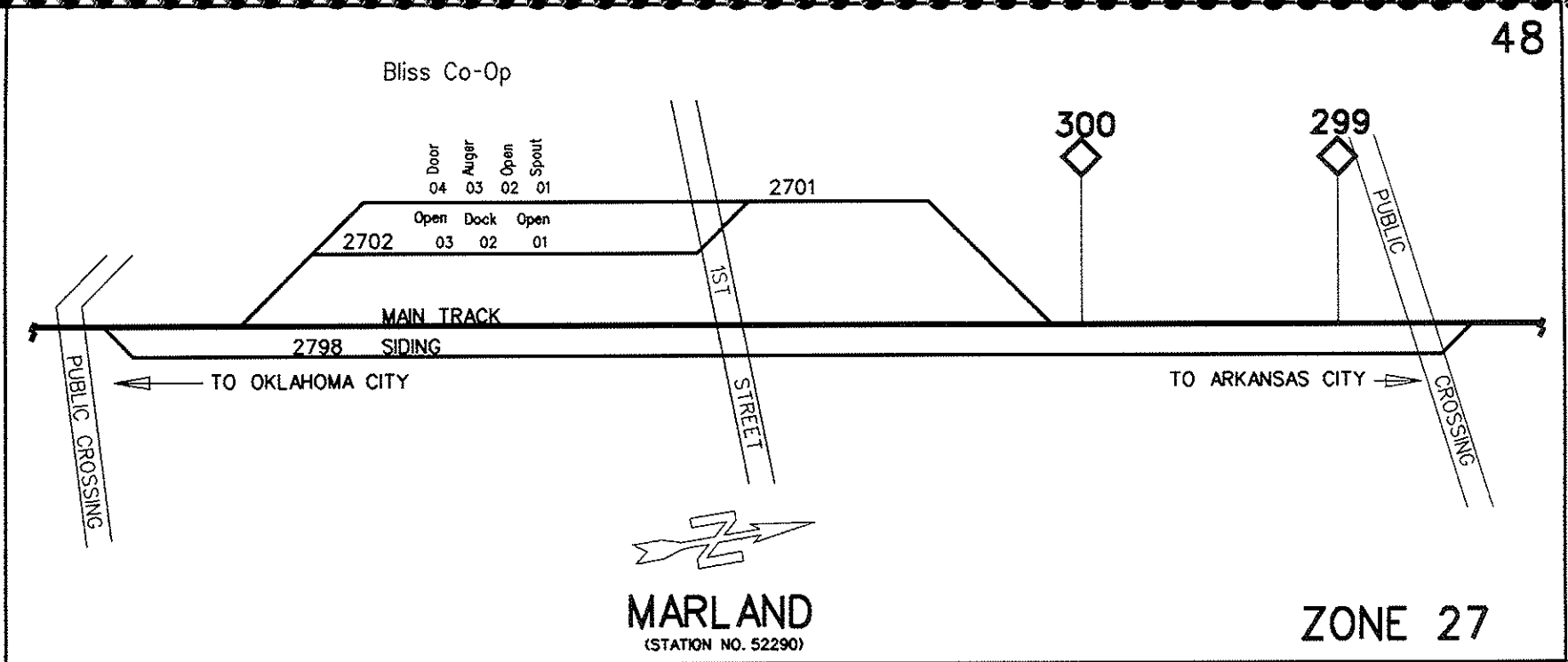

MARLAND
(STATION NO. 52290)

ZONE 27

48

Zone 30 (Red Rock 52280) Oklahoma Subdivision

30 01 00	House Track		30 03 00	Farmers Elev	
30 01 01	Dufek Aerial Spray	(rise)	30 03 01	Farmers Elev	(open)
thru 03			30 03 02	Farmers Elev	(auger)
30 01 10	Team Track Patrons	(open)	30 03 03	Farmers Elev	(open)
30 02 00	Farmers Elev North No 2		thru 04		
30 02 01	Farmers North Elevator	(spout)	30 03 05	Farmers Elev	(riser)
			30 04 00	Farmers Elevator Spur	
			30 10 00	O G & E Lead to Dump	
			30 98 00	Siding	
			30 99 00	Main Track	

Note: North covered hopper spotted for loading must be placed at Spot 01, car centered under spout, with remaining cars trailing to the south.

Note: Santa Fe Engines not allowed on Track 3004

Page 49

C.E. NO. 11803-SK Engineering & Technology Development 4/92

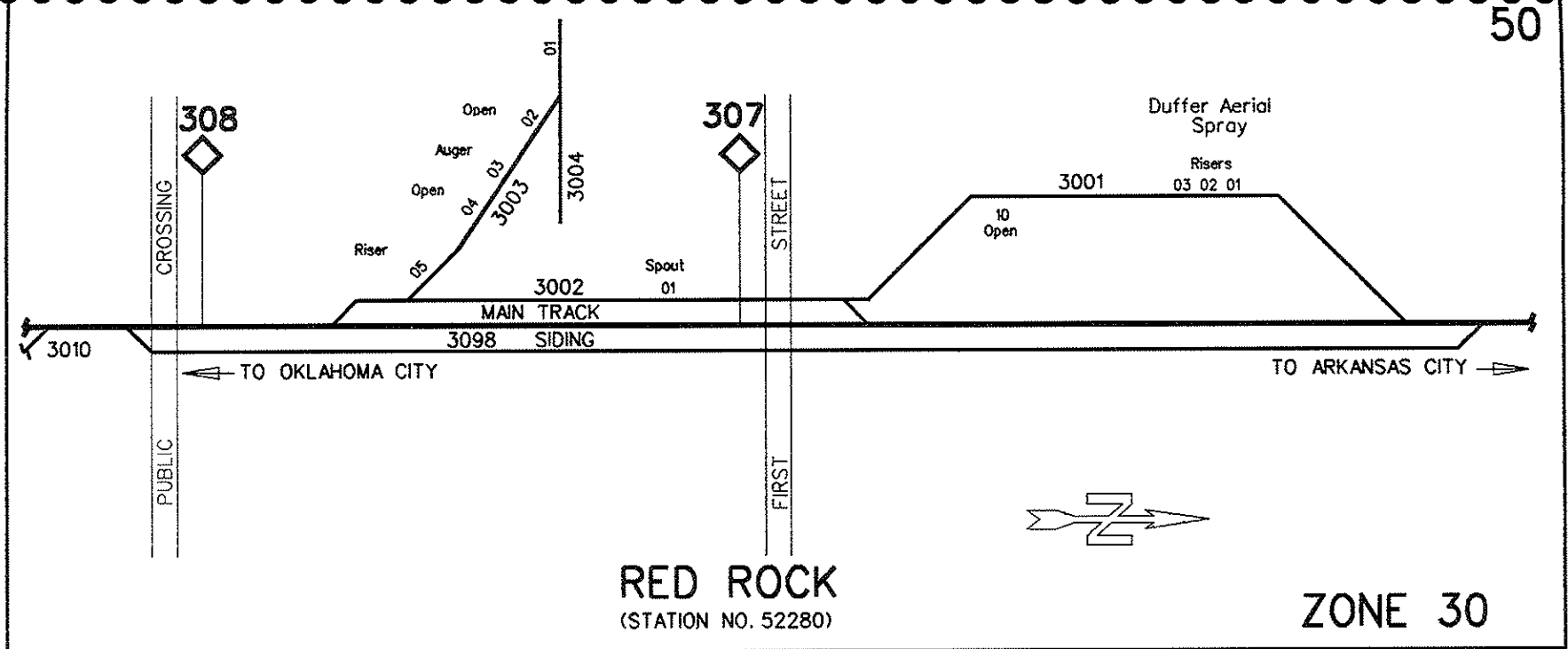

50

50

Zone 30 (Red Rock 52280) Oklahoma Gas & Electric

30 10 00	O G & E Lead to Dump	
30 11 00	O G & E Lead - Transformer Track	
30 11 01	O G & E	(open)
thru 02		
30 12 00	Plant Track No 1	
30 12 01	O G & E	(open)
thru 04		
30 13 00	Plant Track No 2	
30 13 01	O G & E	(open)
thru 02		
03 13 03	Brown & Root Building	(open)
03 13 04	O G & E Warehouse No 6	(open)
03 13 05	O G & E Warehouse No 5	(open)
30 14 00	Back Track	

Page 51

C.E. NO. 11803-SK Engineering & Technology Development 4/92

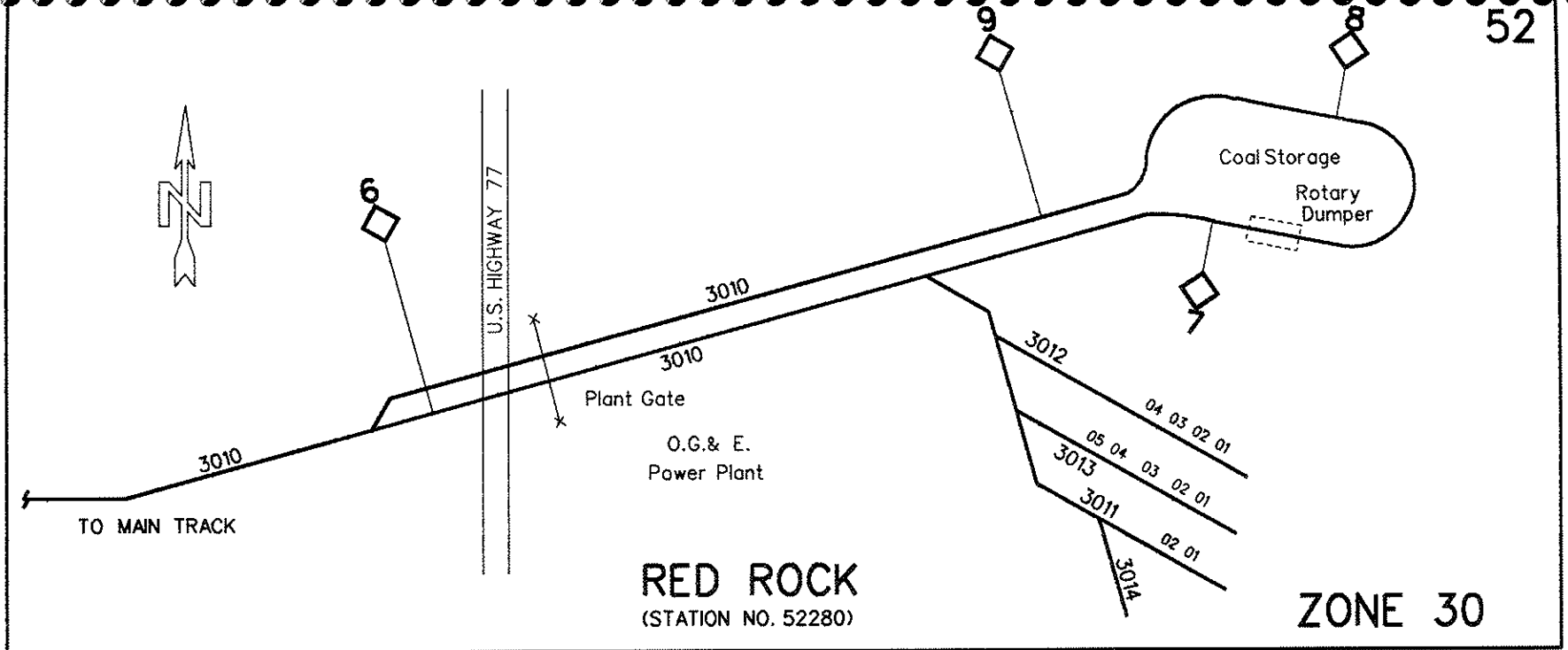

52

52

Zone 36 (Otoe 52270) Oklahoma Subdivision

36 98 00 Siding
36 99 00 Main Track

Zone 46 (Asp 52090) Oklahoma Subdivision

46 98 00 Siding
46 99 00 Main Track

Page 53

C.E. NO. 11804-SK Engineering & Technology Development 4/92

54

54

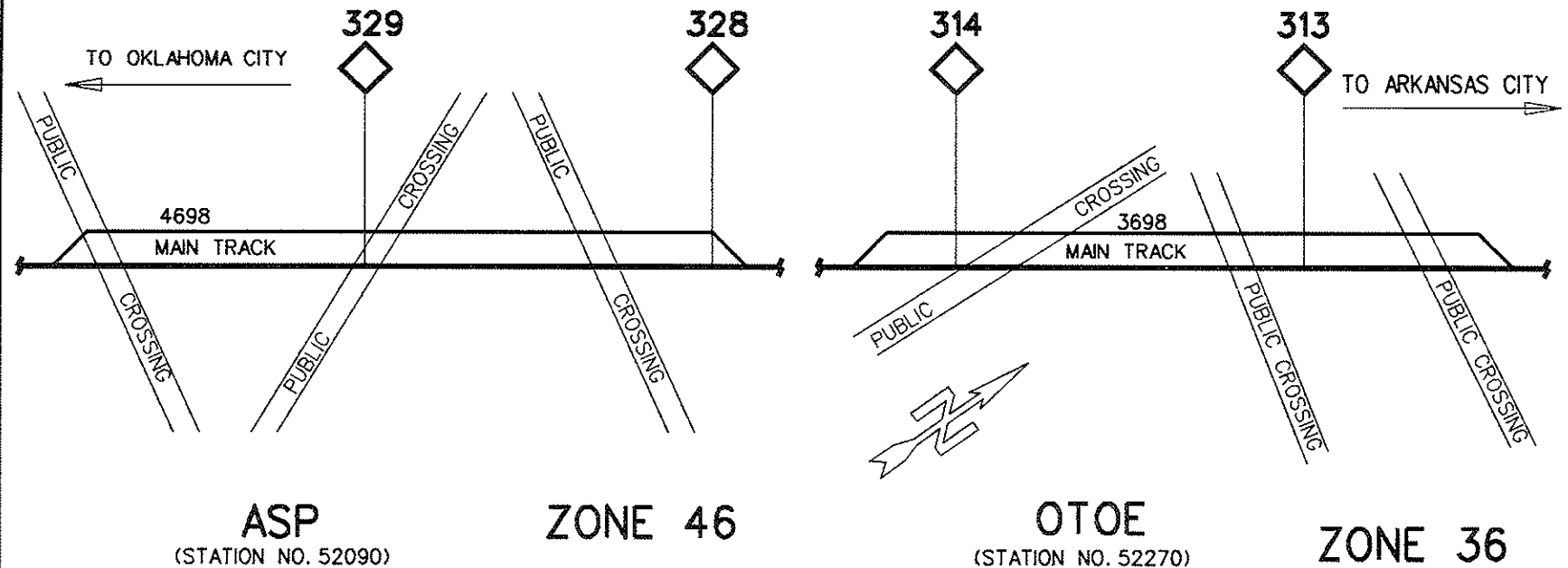

Zone 45 (Perry 52100) Oklahoma Subdivision

45 01 00	Team Track		45 06 00	Perry Elevator Spur	
45 01 01		(oh crane)	45 06 01	Perry Elevator	(open)
thru 02			thru 02		
45 03 00	House Track		45 97 00	New Siding	
45 03 01		(ramp)	45 98 00	Old Siding	
thru 03			45 99 00	Main Track	
45 04 00	BN Connection				
45 05 00	Perry Elevator Track				
45 05 01	Perry Elevator	(chute)			
thru 05					

Page 55

C.E. NO. 11804-SK Engineering & Technology Development 4/92

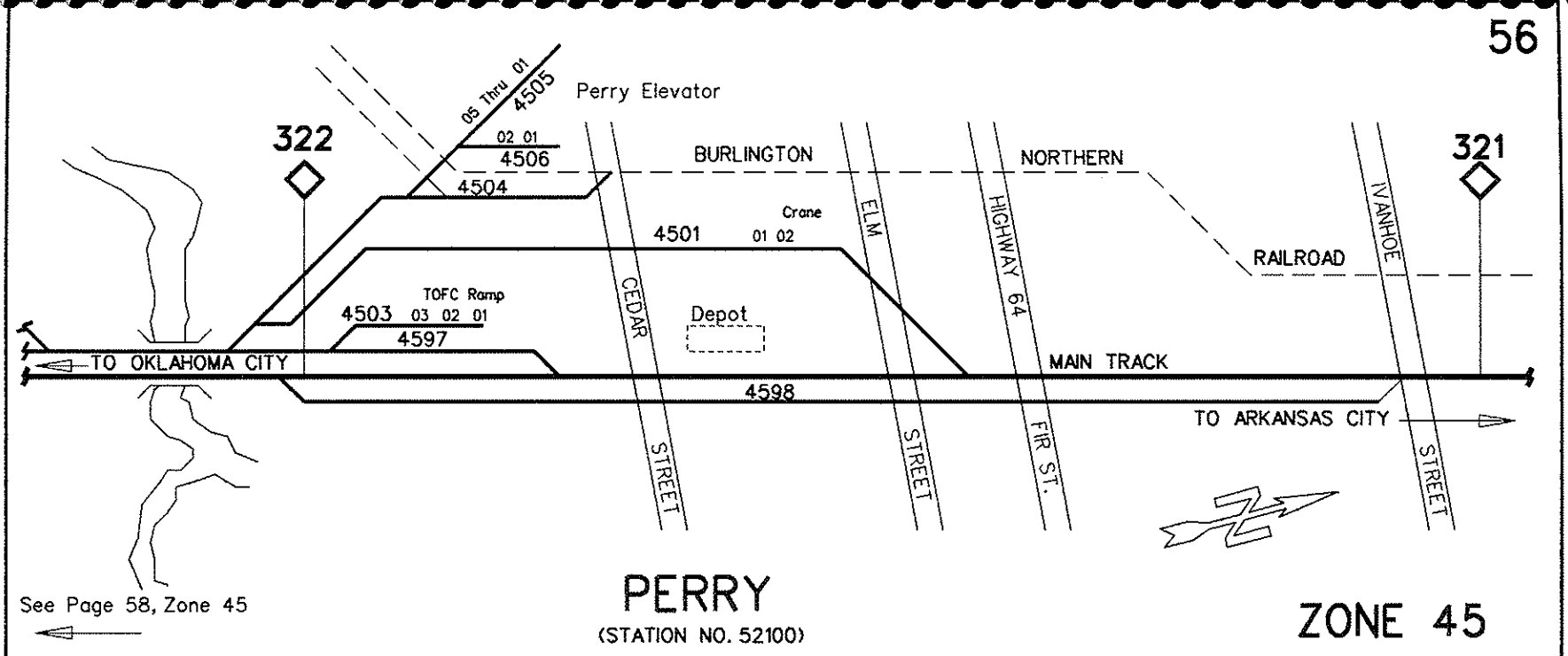

See Page 58, Zone 45

56

56

Zone 45 (Perry 52100) Oklahoma Subdivision

45 03 00	House Track	
45 04 00	BN Connection	
45 07 00	Team Track	
45 07 01	Team Track	(open)
45 11 00	Yard Track No 1	
45 12 00	Yard Track No 2	
45 13 00	Yard Track No 3	
45 97 00	New Siding	
45 98 00	Old Siding	
45 99 00	Main Track	

Page 57

C.E. NO. 11804-SK Engineering & Technology Development 4/92

58

58

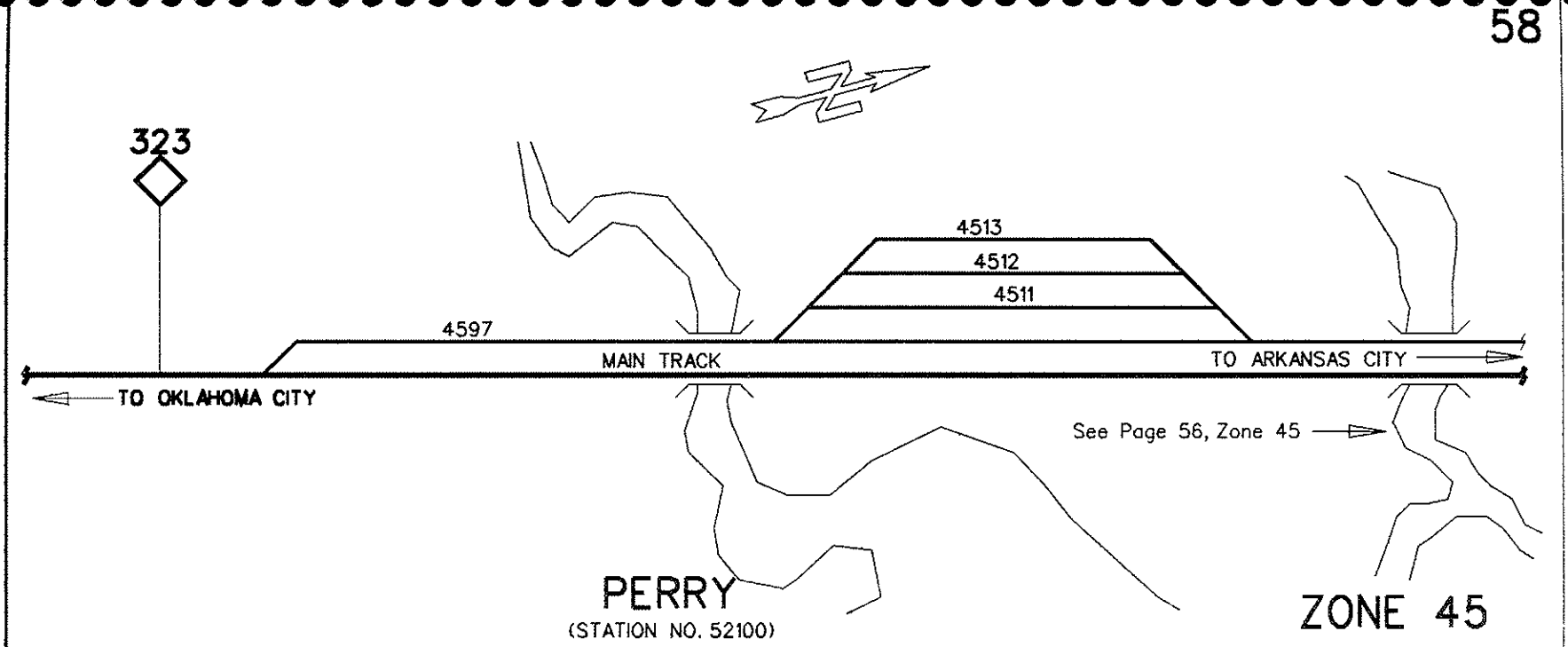

PERRY
(STATION NO. 52100)

ZONE 45

Zone 11 (Mulhall 52060) Oklahoma Subdivision

11 51 00	United Coop-Mulhall Team	
11 51 01	United Coop Elevator	(oh spout)
11 51 10	Team Track Patrons	(open)
11 96 00	Mulhall Siding	
11 99 00	Okla Subdivision Main	

Page 59

C.E.NO.11804-SK Engineering & Technology Development 4/92

60

60

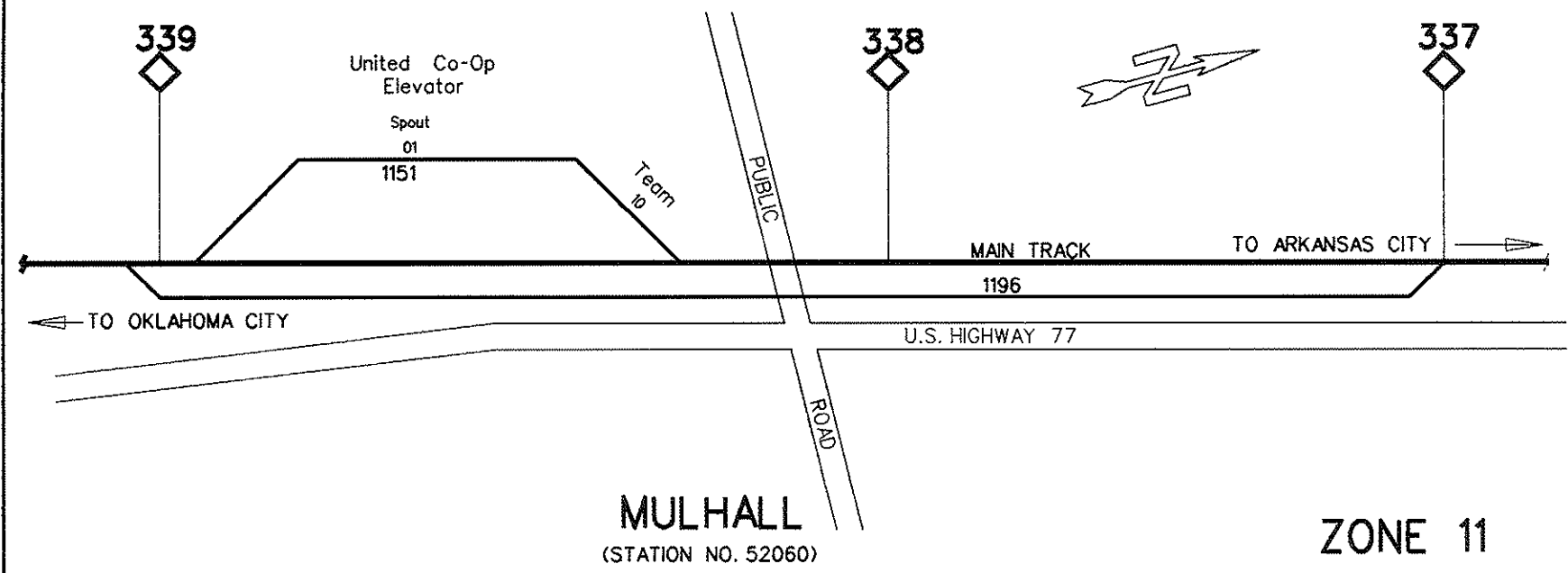

Zone 71 (Lawrie 52050) Oklahoma Subdivision

- 71 98 00 Lawrie Siding
- 71 99 00 Main Track

Zone 83 (Seward 51695) Oklahoma Subdivision

- 83 98 00 Seward Siding
- 83 99 00 Main Track

C.E.NO.11804-SK Engineering & Technology Development 4/92

62

62

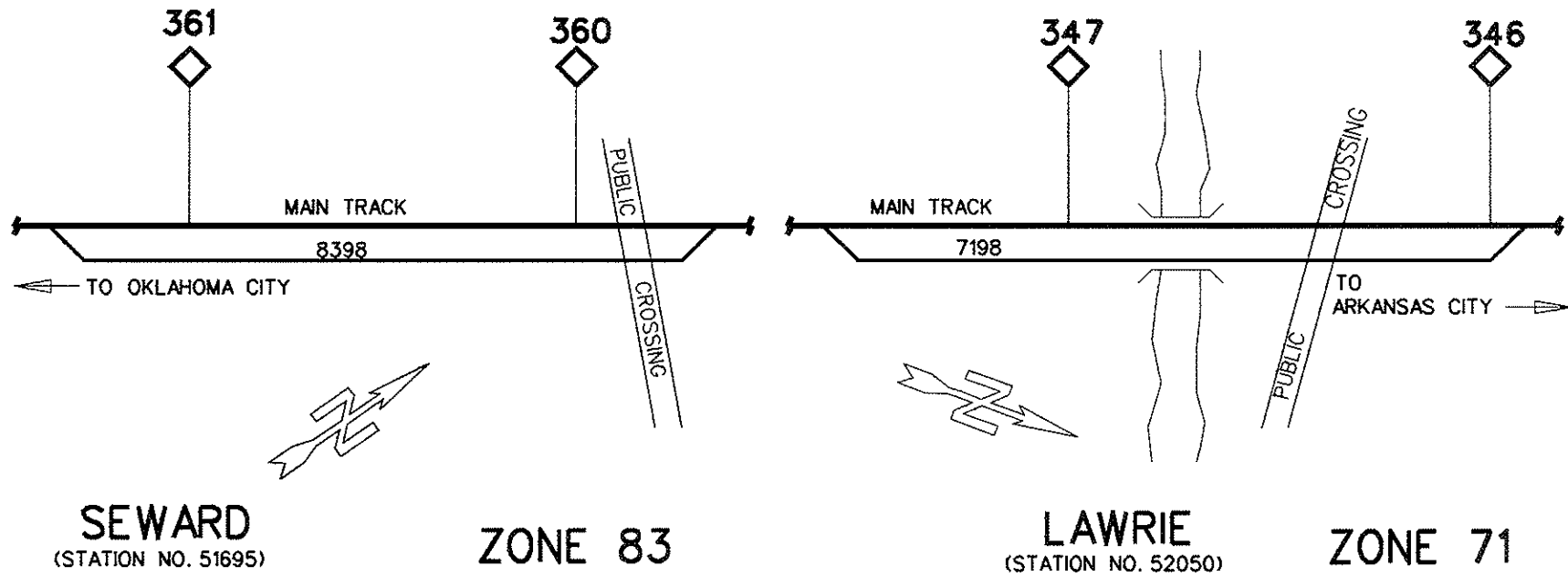

Zone 11 (Guthrie 51700) Oklahoma Subdivision

- 11 27 00 Guthrie Cotton Oil Co Track
- 11 27 00 Guthrie Cotton Oil Co
- 11 27 01 Guthrie Cotton Oil Co (open)
- 11 27 02 Guthrie Cotton Oil Co (hose)
- 11 27 03 Guthrie Cotton Oil Co (spout)
- 11 27 04 Guthrie Cotton Oil Co (auger)
- 11 97 00 Enid Subdivision Main Track
- 11 98 00 Guthrie Siding
- 11 99 00 Oklahoma Subdivision Main Track

C.E.NO.11804-SK Engineering & Technology Development 4/92

64

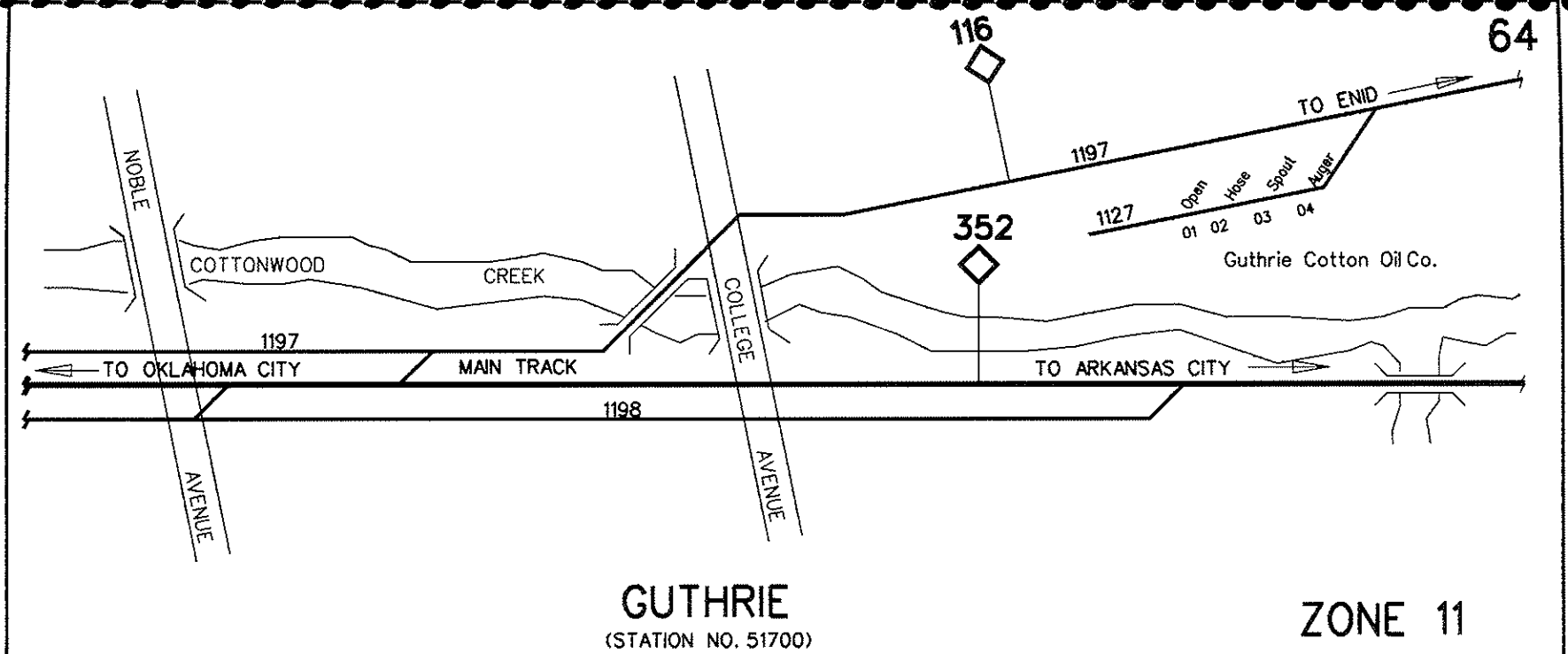

GUTHRIE
(STATION NO. 51700)

ZONE 11

Zone 11 (Guthrie 51700) Oklahoma Subdivision

11 02 00	Yard Track		11 29 00	New House Team Track	
11 08 00	West Coach Track		11 29 01	Team	
11 11 00	South Leg of Wye		thru 02		(dock)
11 12 00	Katy Lead		11 30 00	East House Team Track	
11 14 00	North Leg of Wye		11 30 01	Team	(dock)
11 21 00	Guthrie Cotton Oil		11 36 00	Guthrie Team	(open)
11 21 01	Guthrie Cotton Oil	(spout)	11 97 00	Enid Subdivision Main Track	
11 21 02	Guthrie Cotton Oil	(dock)	11 98 00	Guthrie Siding	
11 22 00	Old Scale Track-Guthrie Cotton		11 99 00	Oklahoma Subdivision Main Track	
11 22 01	Guthrie Cotton Oil	(hose)			

Page 65

C.E. NO. 11804-SK Engineering & Technology Development 4/92

66

66

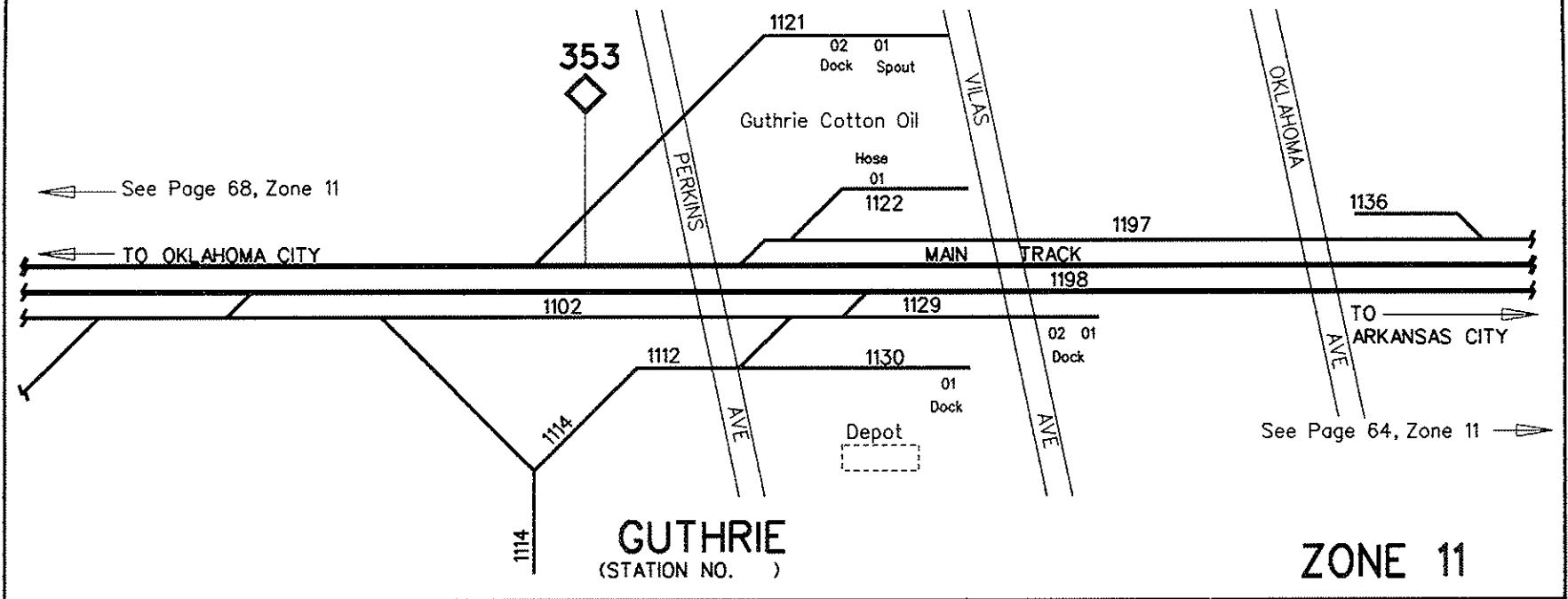

GUTHRIE
(STATION NO.)

ZONE 11

Zone 11 (Guthrie 51700) Oklahoma Subdivision

- 11 01 00 Trk 1102 Extension
- 11 02 00 Yard Track
- 11 03 00 Yard Track
- 11 04 00 Yard Track
- 11 05 00 Yard Track
- 11 06 00 Yard Track
- 11 07 00 Yard Track
- 11 09 00 East Coach Track
- 11 98 00 Guthrie Siding
- 11 99 00 Oklahoma Subdivision Main Track

Page 67

C.E. NO. 11804-SK Engineering & Technology Development 4/92

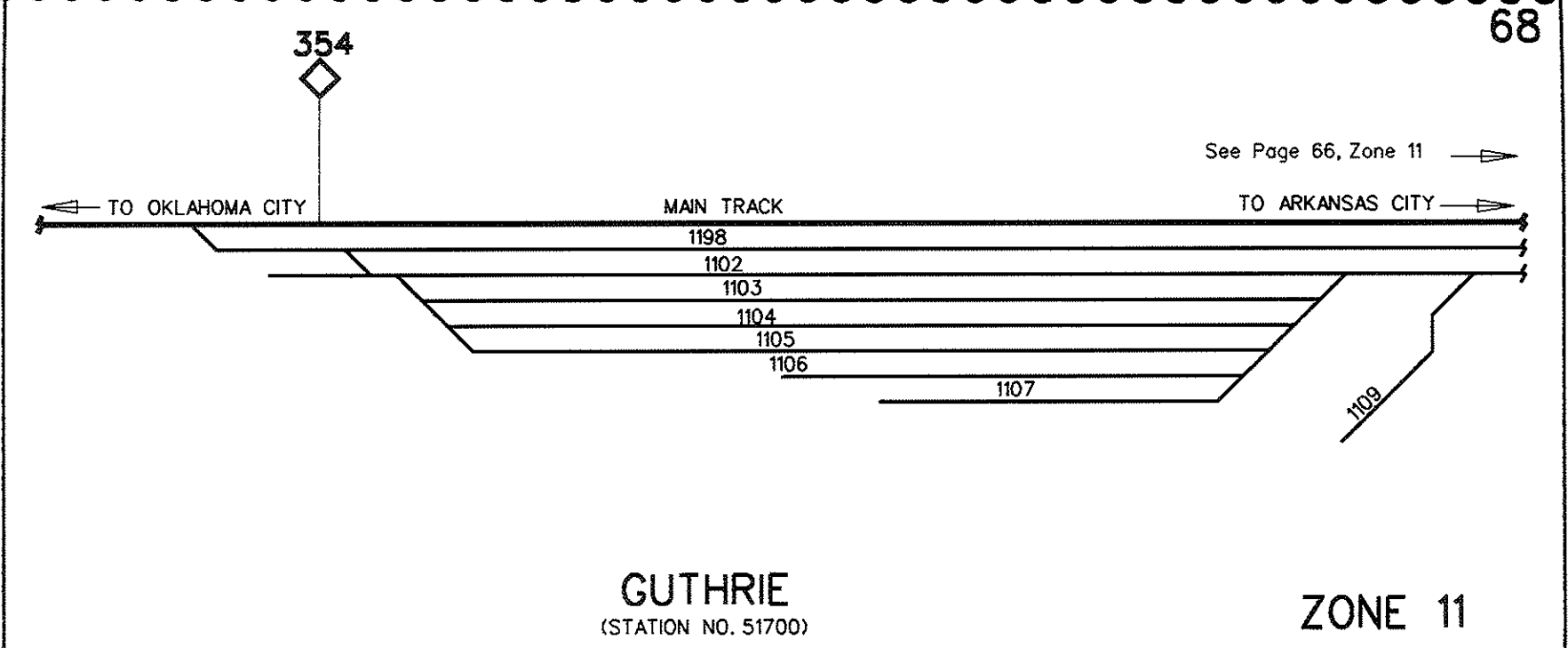

68

68

GUTHRIE
(STATION NO. 51700)

ZONE 11

Zone 04 (Edmond 51690) Oklahoma Subdivision

04 42 00	Edmond Team Track	
04 42 01	Team Track Patrons	(open)
04 43 00	International Paper	
04 43 01	Long Bell Lumber Co	(open)
thru 05		
04 50 00	Pipe Yard Team Track (MP 367)	
04 50 01	Team Track Patrons	(open)
thru 13		
04 97 00	Edmond Siding	
04 99 00	Main Track	

Page 69

C.E. NO. 1804-SK Engineering & Technology Development 4/92

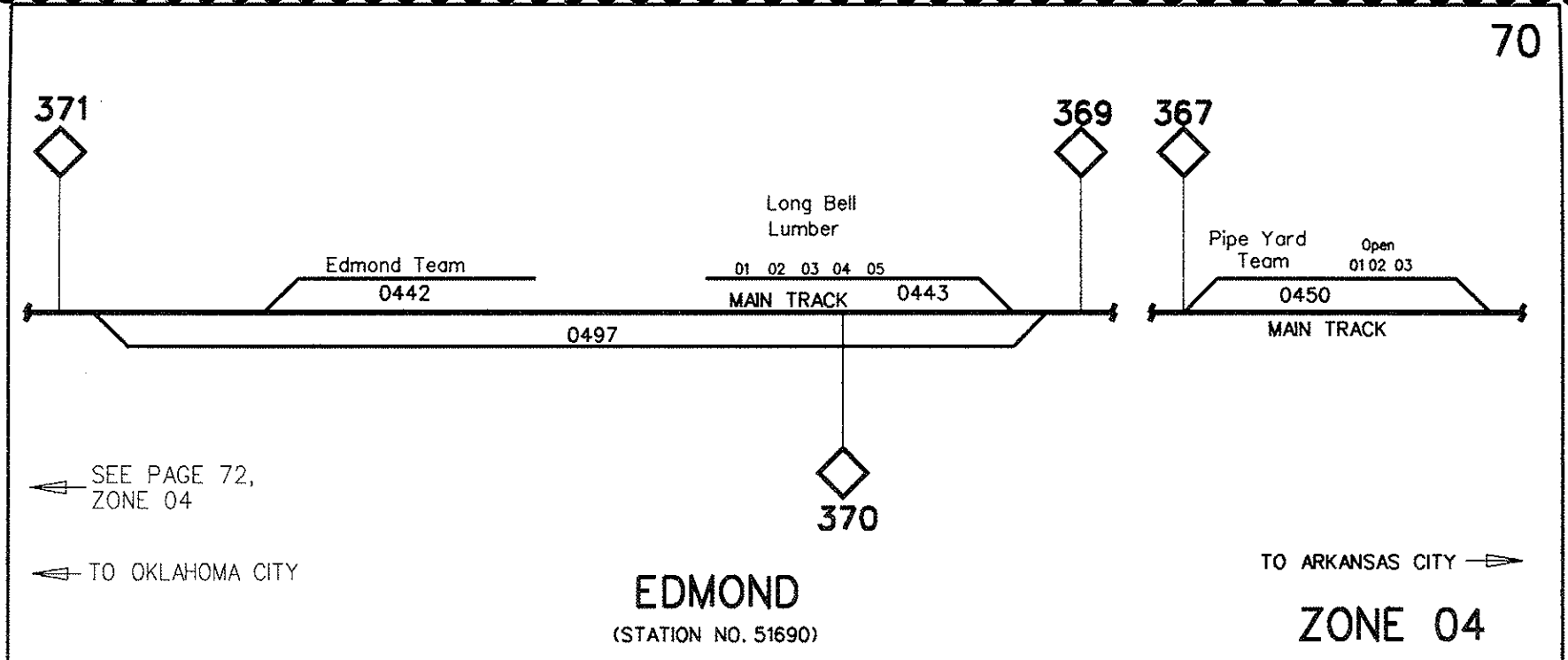

70

70

Zone 04 (Edmond 51690) Oklahoma Subdivision

04 24 00	Murphy Perkins				
04 24 01	Murphy Perkins	(open)			
thru 05					
04 26 00	Old TG&Y Tail Track		04 32 00	Hope Lumber	
04 27 00	Box Crow Cement		04 32 01	Hope Lumber	(open)
04 27 01	Box Crow Cement	(open)	thru 03		
thru 20			04 94 00	Ralston Siding (by Murphy Perkins)	
04 28 00	Box Crow Cement		04 95 00	Ralston Siding (by TG&Y)	
04 28 01	Box Crow Cement (open)		04 99 00	Main Track	
thru 09					

C.E. NO. 11804-SK Engineering & Technology Development 4/92

72

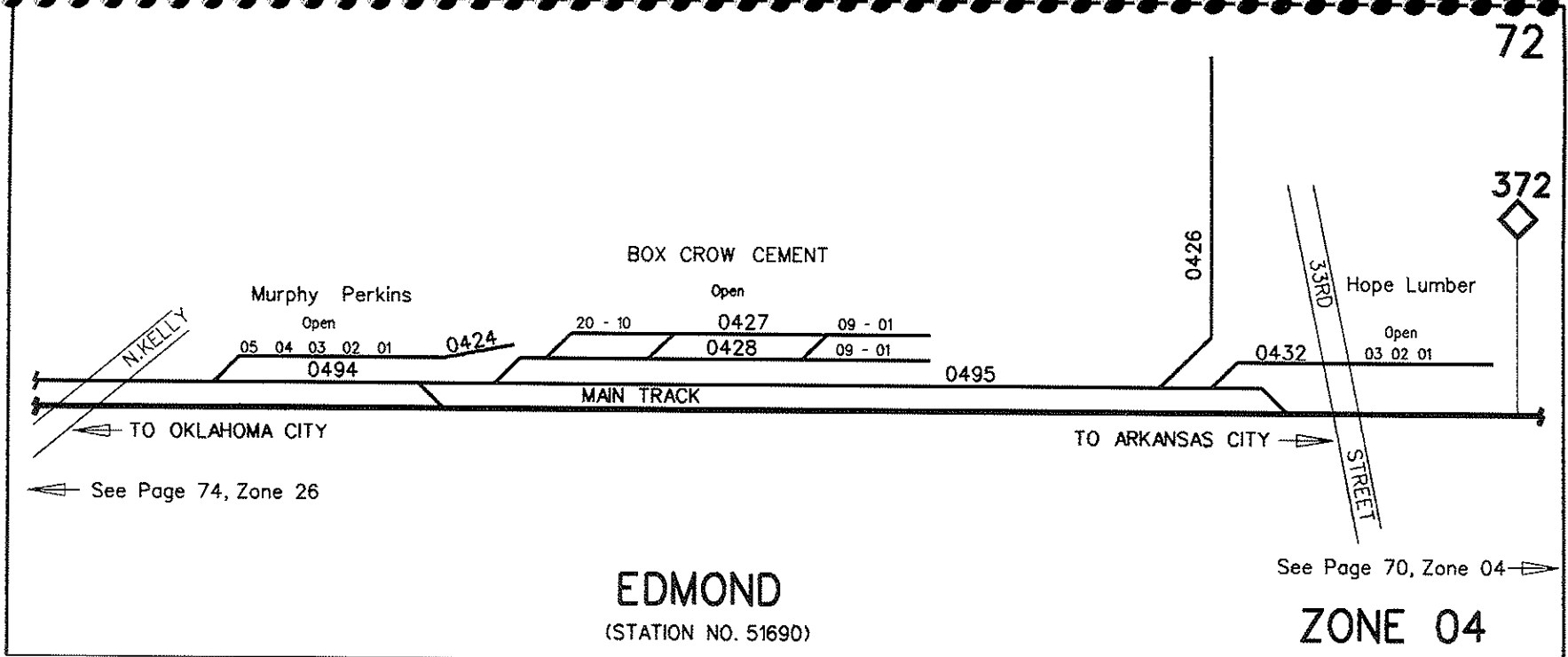

ZONE 04

Zone 04 (Edmond 51690) Oklahoma Subdivision

04 17 00	Ralston Purina Stub Track	
04 18 00	Ralston Purina No 2	
04 18 01	Ralston No 2	(inside)
thru 08		
04 19 00	Ralston Purina No 3 Track	
04 19 01	Ralston No 3	(open)
thru 12		
04 20 00	Ralston Scale Track	
04 30 00	North Memorial Road Lead	
04 31 00	Fleming	
04 31 00		(door)
thru 05		
04 93 00	Ralston Siding (by Ralston)	
04 99 00	Main Track	

Page 73

C.E. NO. 11804-SK Engineering & Technology Development 4/92

74

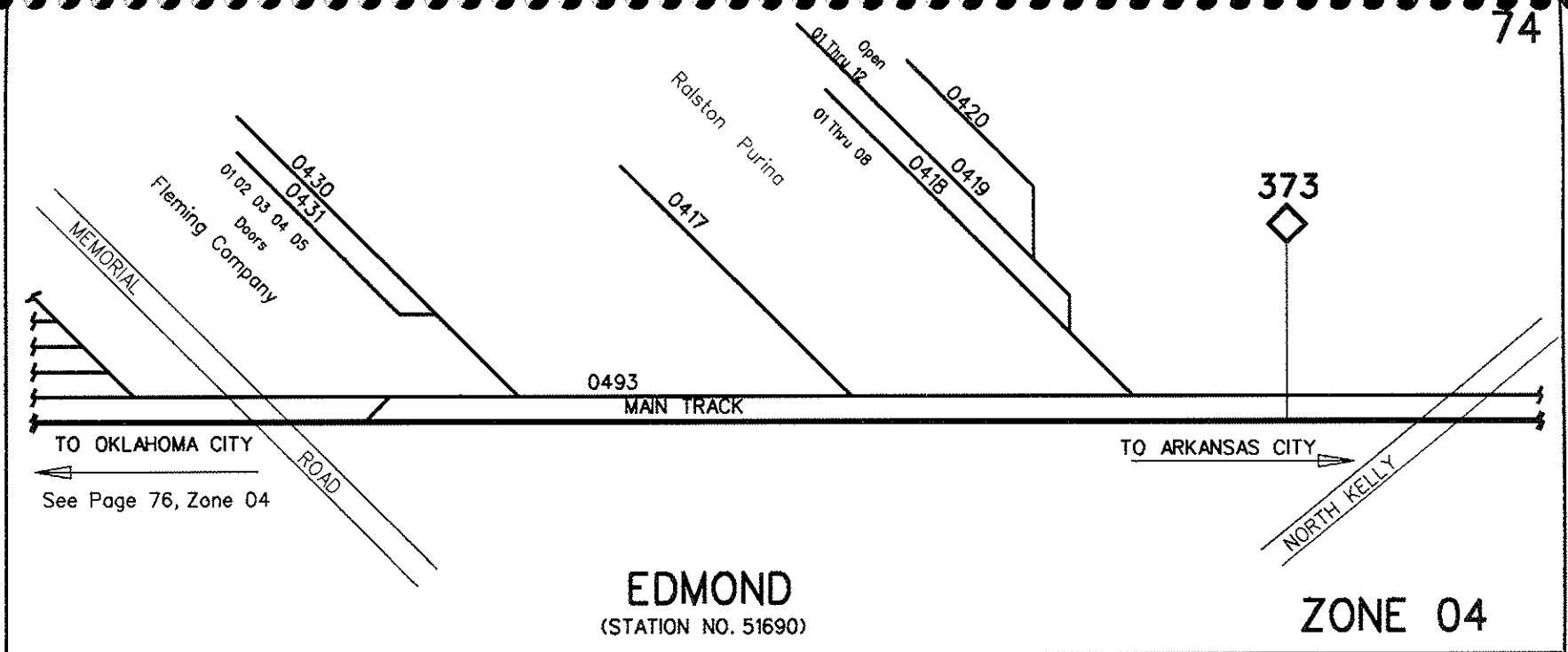

74

Zone 04 (Britton 51680) Oklahoma Subdivision

04 01 00	Britton Team		04 11 00	Cain Coffee Track	
04 01 01	Team Track Patrons	(open)	04 11 01	Cain Coffee Co	(door)
thru 10			thru 04		
04 06 00	Acme Brick Track		04 12 00	Dereco Lead Track	
04 06 01	Acme Brick Co	(hose)	04 13 00	Dereco Yard Track	
04 06 02	Acme Brick Co	(dock)	04 14 00	Dereco Yard Track	
thru 06			04 15 00	Dereco Yard Track	
04 07 00	South Memorial Road Lead		04 16 00	Dereco Yard Track	
04 08 00	Fleming		04 91 00	Ralston Siding (by Acme Brick)	
04 08 01	Fleming Co	(inside)	04 92 00	Ralston Siding (by Dereco Yard)	
thru 03			04 98 00	Britton Siding	
			04 99 00	Main Track	

Page 75

C.E. NO. 11804-SK Engineering & Technology Development 4/92

76

76

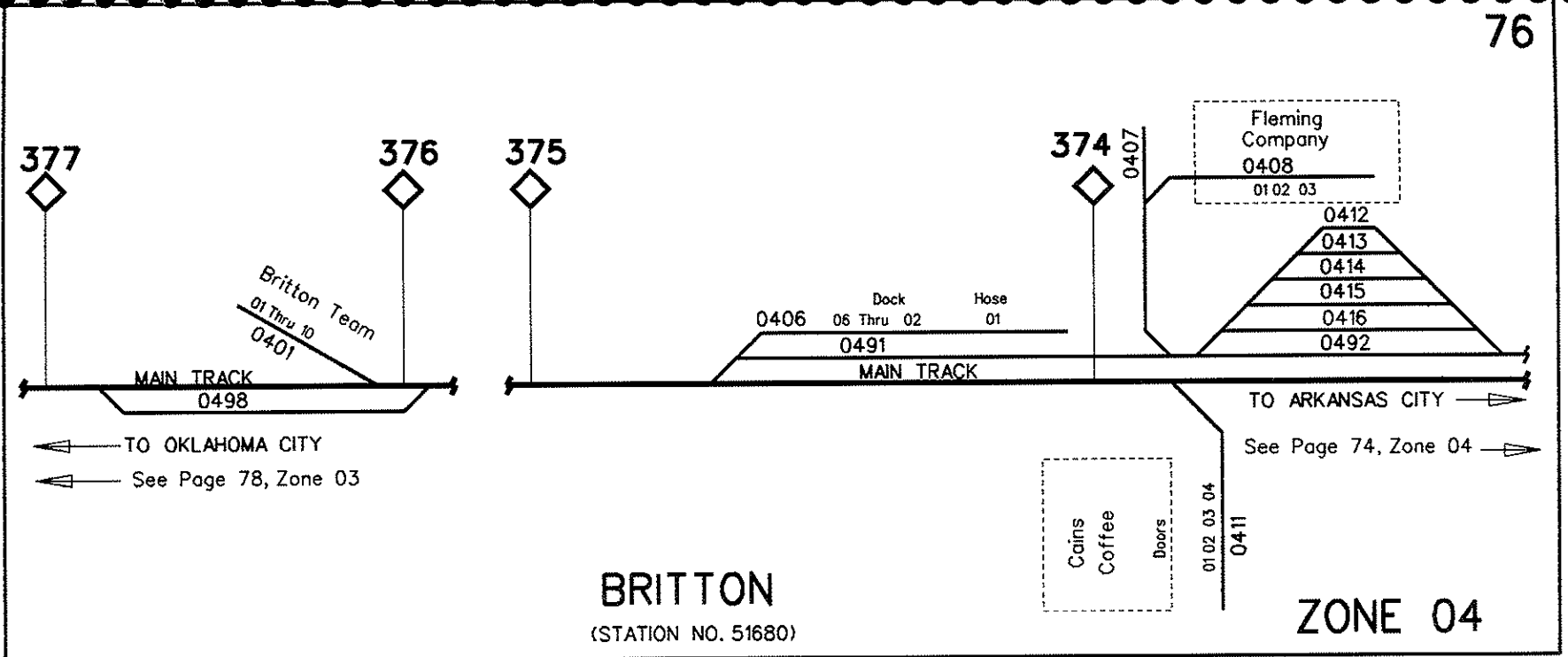

Zone 03 (Oklahoma City 51500) Oklahoma Subdivision

- 03 24 00 Clements Foods Vacant
- 03 24 01 Clements Foods (door)
- thru 03
- 03 25 00 Clements Foods
- 03 25 01 Clements Foods
- thru 05
- 03 27 00 Whilshire Siding
- 03 28 00 Kraft Foods Div.
- 03 28 01 Kraft Foods Div.
- thru 08
- 03 99 00 Oklahoma City Main Track

Page 77

C.E.NO.11804-SK Engineering & Technology Development 4/92

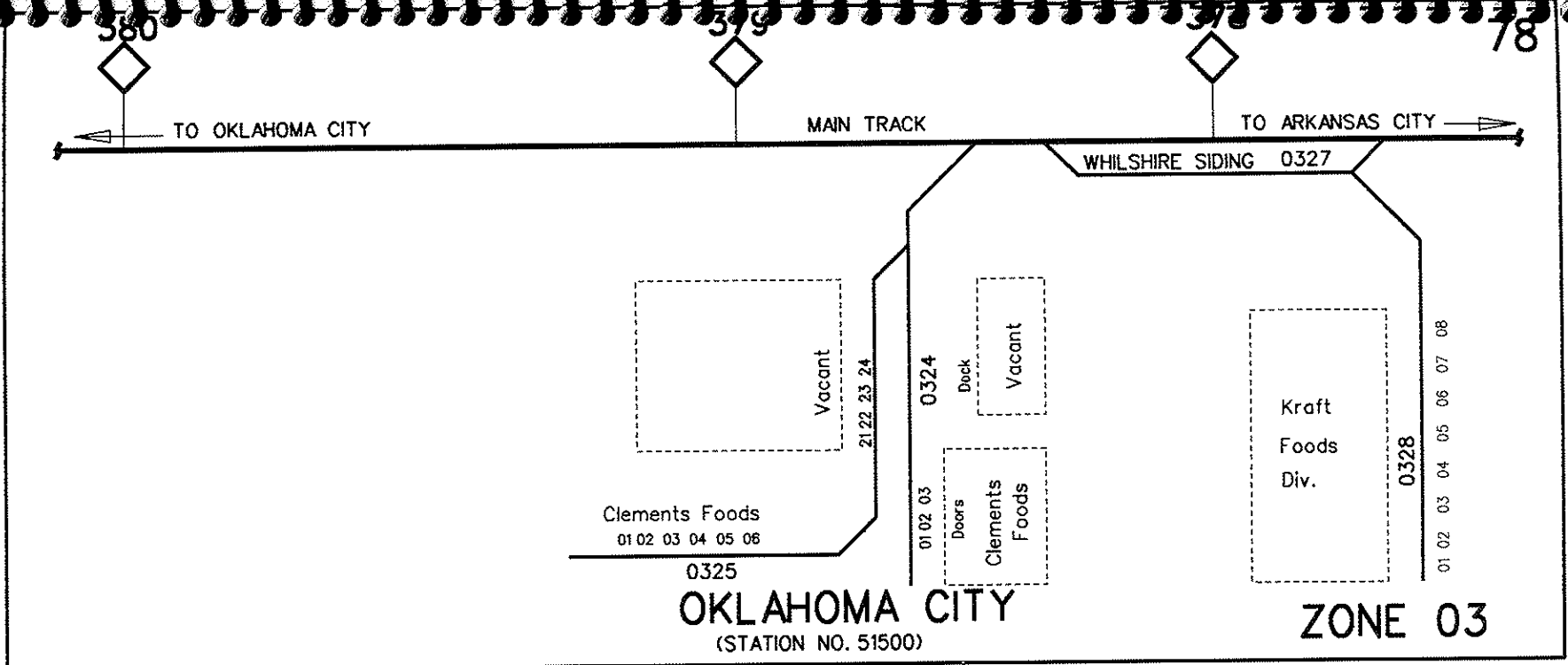

78

Zone 03 (Oklahoma City 51500) Oklahoma Subdivision

03 01 00 Macklanburg Duncan
 03 01 01 Macklanburg Duncan (open)
 thru 03
 03 02 00 T G & Y Central Mdse
 03 02 01 Vacant (door)
 thru 07
 03 03 00 Macklanburg Duncan
 03 03 01 Macklanburg Duncan (door)
 thru 03
 03 50 00 Pass Track
 03 98 00 South Main Track
 03 99 00 North Main Track

Page 79

C.E.NO. 11804-SK Engineering & Technology Development 4/92

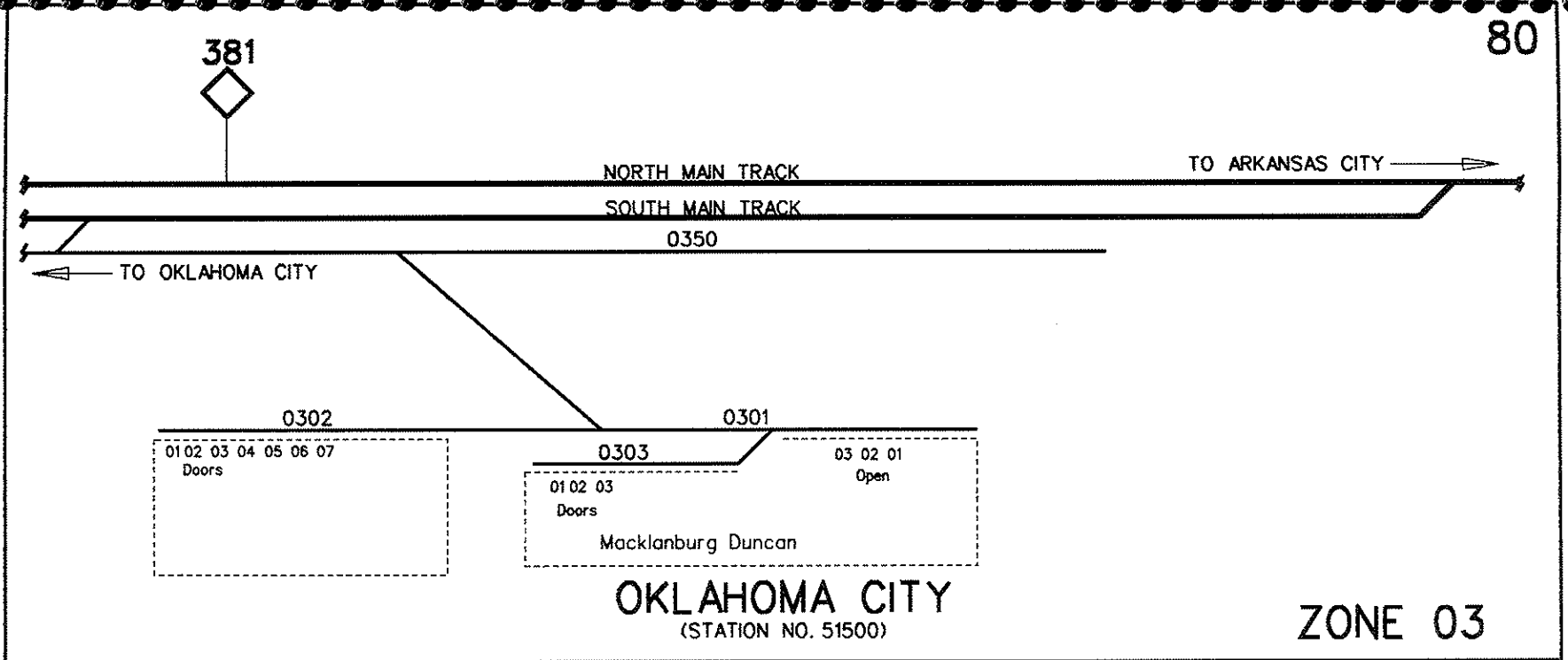

80

80

Zone 01 (Oklahoma City 51500) Oklahoma Subdivision

01 11 00	Commercial Whse Track		01 13 11	Vacant	(dock)
01 11 01	Commercial Whse	(inside)	thru 12		
thru 07			01 50 00	Pass	
01 12 00	Commercial Whse Track		01 51 00	Trk No. 1	
01 12 01	Commercial Whse	(dock)	01 52 00	Trk No. 2	
thru 08			01 53 00	OKC-Nowers Trk No. 3	
01 13 00	SWStationary-Santa Fe Sales		01 54 00	Trk No. 4	
01 13 01	SWStationary	(dock)	01 55 00	Trk No. 5	
01 13 02	Vacant	(dock)	01 56 00	Trk No. 6	
thru 03			01 57 00	Trk No. 7	
01 13 04	Santa Fe Sales	(dock)	01 58 00	Nowers Yard Lead	
thru 06			01 98 00	South Main Trk (EBML)	
			01 99 00	North Main Trk (WBML)	

Page 81

C.E. NO. 11804-SK Engineering & Technology Development 4/92

82

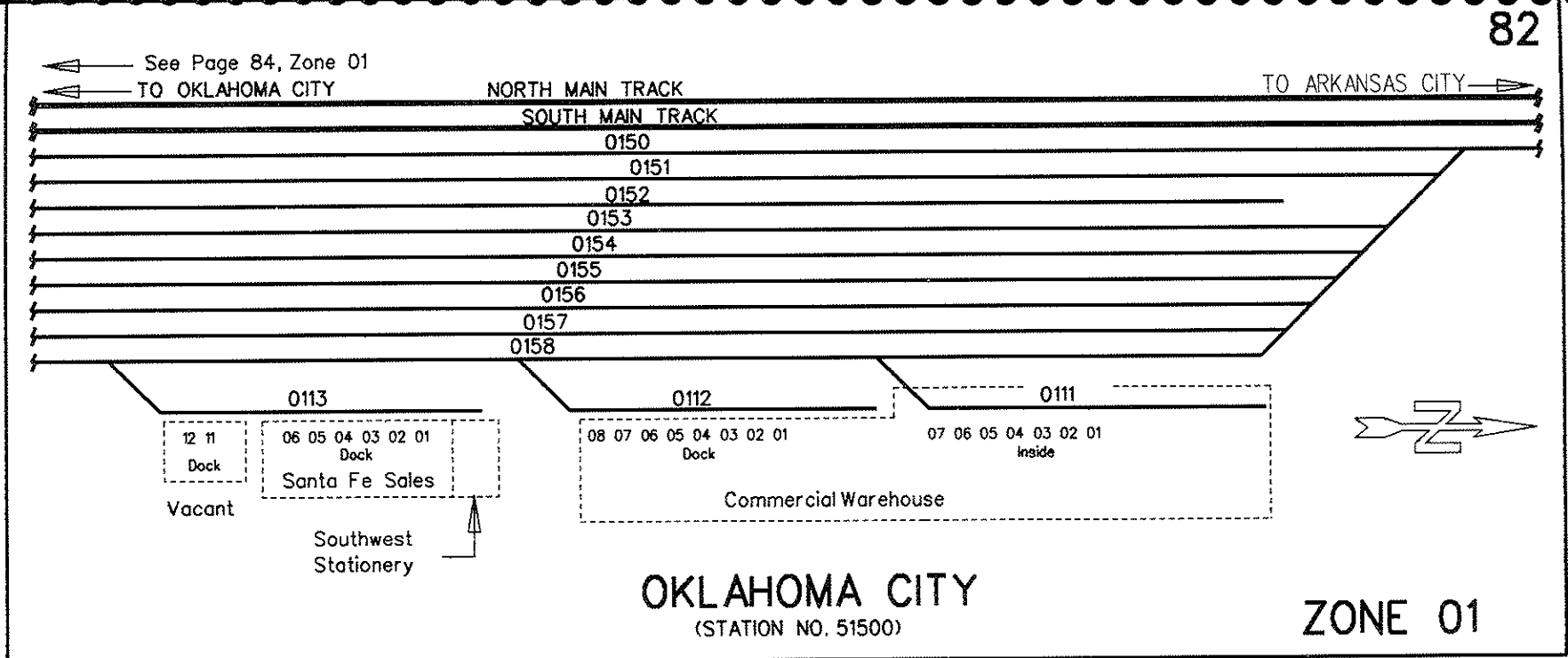

Zone 01 (Oklahoma City 51500) Oklahoma Subdivision

01 50 00 Pass
 01 51 00 Trk No. 1
 01 52 00 Trk No. 2
 01 53 00 OKC-Nowers Trk No. 3
 01 54 00 Trk No. 4
 01 55 00 Trk No. 5
 01 56 00 Trk No. 6
 01 57 00 Trk No. 7
 01 58 00 Nowers Yard Lead
 01 98 00 South Main Trk (EBML)
 01 99 00 North Main Trk (WBML)
 02 74 00 Lincoln Lead

C.E. NO. 11804-SK Engineering & Technology Development 4/92

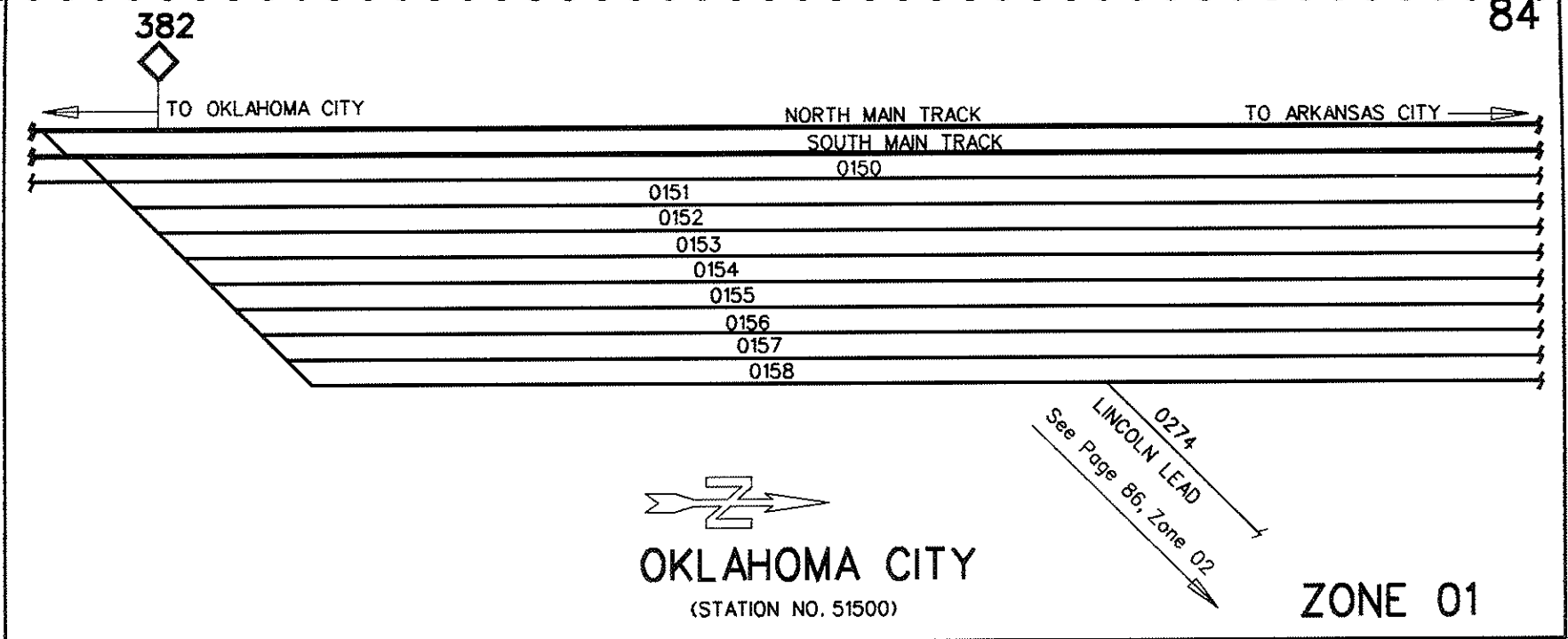

Zone 02 (Oklahoma City 51500) Oklahoma Subdivision

02 01 00	Warren-Waugh Bros-Pritchard	02 06 00	Huttig Sash & Door	02 12 00	Bradford Industrial Supply
02 01 00	Warren Transfer (door)	02 06 01	Huttig Sash & Door (door)	02 12 01	Bradford Industrial Supply (door)
thru 02		thru 04		02 13 00	Pro Tread Corp
02 01 10	Waugh Brothers (door)	02 07 00	Medallion Chemical	02 13 01	Pro Tread Corp (door)
02 01 20	Pritchard Warehouse (door)	02 07 01	Medallion Chemical (door)	thru 04	
02 02 00	G E Whse	02 08 00	Otasco	02 14 00	Champion Bldrs
02 02 01	General Electric Whse (door)	02 08 01	Otasco (door)	02 14 01	Champion Bldrs (door)
thru 04		thru 02		thru 03	
02 03 00	Dupont	02 09 00	Modern Distributors	02 74 00	Lincoln Lead
02 03 01	Dupont Co (door)	02 09 01	Modern Distributors (door)		
thru 04		thru 02			
02 04 00	200 Zone North Lead	02 10 00	Far Eastern Imports		
02 05 00	Jim Walter-Data Documents	02 10 01	Far Eastern Imports (door)		
02 05 01	Jim Walters Paper (door)	thru 02			
thru 03		02 11 00	Coors Central-OKC		
02 05 10	Data Documents (dock)	02 11 01	Coors Central (door)		
thru 11		thru 05			

C.E. NO. 11804-SK Engineering & Technology Development 4/92

86

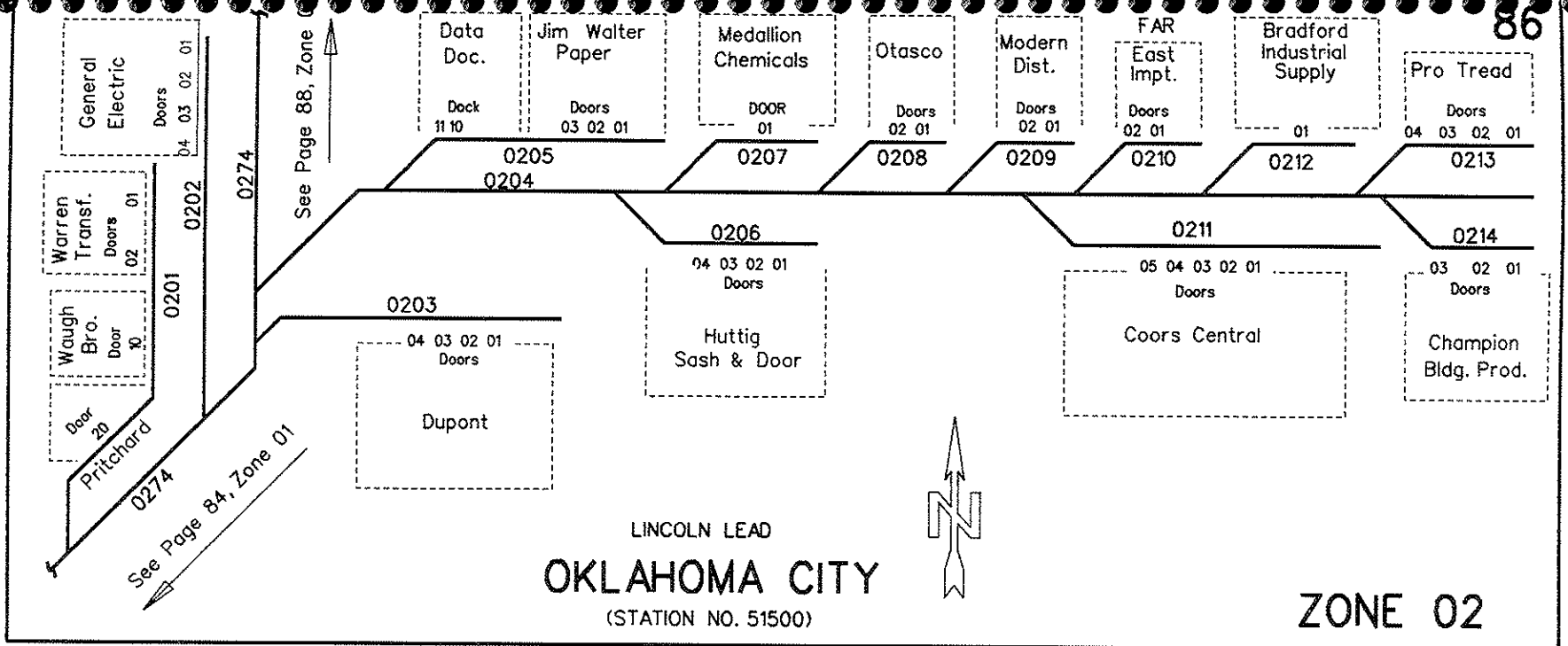

Zone 02 (Oklahoma City 51500) Oklahoma Subdivision

02 15 00	Safeway Tail Track	02 22 00	Gas & Elec Equip-Western Ppr	02 25 00	Nabisco Spur
02 16 00	J & M Cartage	02 22 01	Gas & Elec Equip (door)	02 25 01	Nabisco (door)
02 16 01	J & M Cartage (door)	thru 02		thru 03	
thru 02		02 22 10	Western Paper (door)	02 26 00	Corrugated Packaging Spur
02 17 00	200 Zone South Lead	thru 11		02 26 01	Corrugated Packaging (dock)
02 18 00	Comfort Inc	02 23 00	Sysco Mid-Central-B&L Ctge	02 26 02	Corrugated Design (dock)
02 18 01	Comfort Inc (door)	02 23 01	Sysco Mid-Central (door)	02 27 00	Kraft Foods
thru 02		thru 02		02 27 01	Kraft Foods (door)
02 19 00	A-K News	02 23 10	B & L Cartage (door)	thru 02	
02 19 01	A-K News	thru 11		02 74 00	Lincoln Lead
02 20 00	Ballenger and/or John Thomas	02 23 20	Vacant Whse (door)		
02 20 01	Ballenger and/or (door)	thru 21			
thru 02	John Thomas Furniture	02 24 00	Continental Plastics		
02 21 00	Standard Asbestos	02 24 01	Continental Plastics (door)		
02 21 01	Std Asbestos/Roofing (door)	thru 03			
02 21 02	Std Asbestos/Roofing (gate)	02 24 04	Continental Plastics (door)		

Page 87

C.E. NO. 11804-SK Engineering & Technology Development 4/92

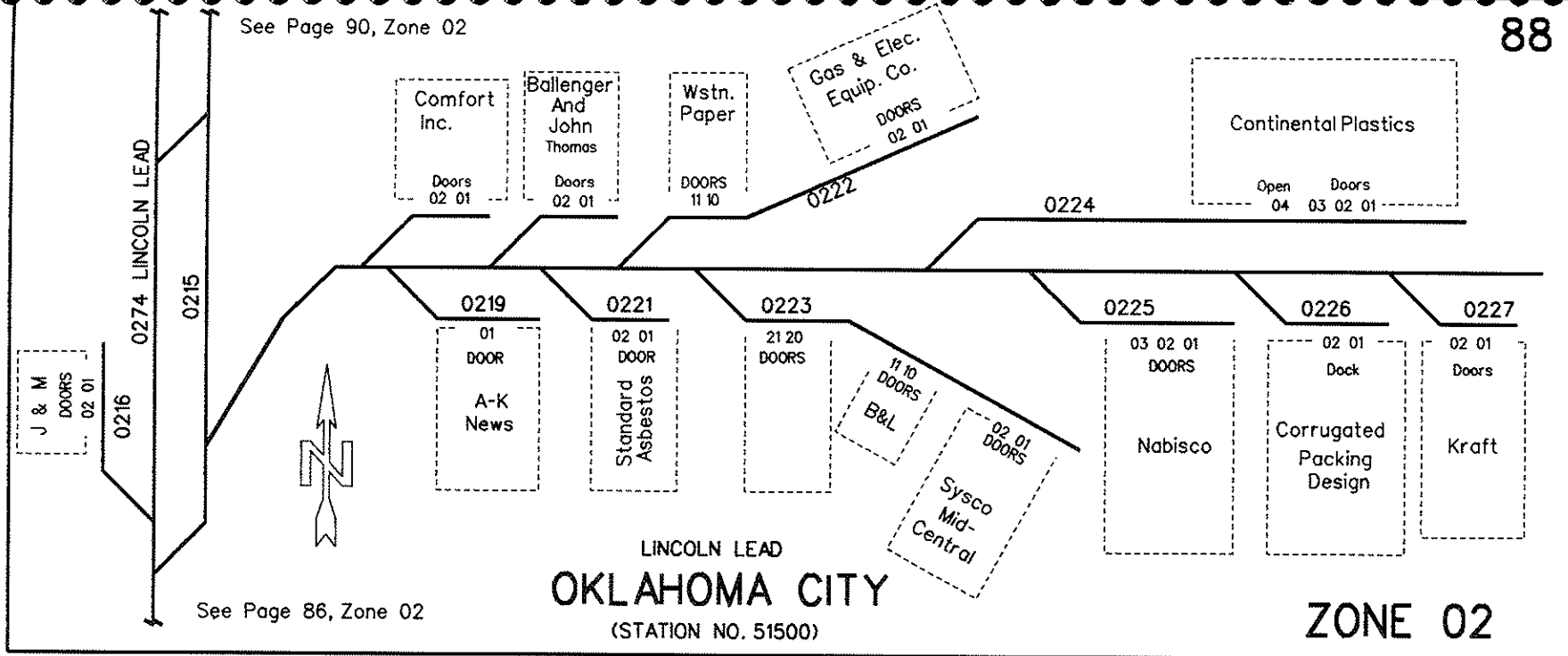

See Page 86, Zone 02

See Page 90, Zone 02

88

88

LINCOLN LEAD
OKLAHOMA CITY
(STATION NO. 51500)

ZONE 02

Zone 02 (Oklahoma City 51500) Oklahoma Subdivision

02 15 00 Safeway Tail Track
 02 28 00 Vacant
 02 28 01 Vacant Whse (inside)
 thru 04
 02 29 00 Pig Ramp No. 1 (dock)
 02 30 00 Pig Ramp No. 2 (dock)
 02 31 00 Pig Ramp No. 3 (dock)
 02 32 00 House-Team Track (door)
 02 32 01 Vacant
 thru 03
 02 33 00 Safeway Grocery Whse (inside)
 02 33 01 Safeway (grocery)

02 34 00 Safeway Frozen Food Whse (inside)
 02 34 01 Safeway (frozen food) (dock)
 02 35 00 Pig Ramp No. 5
 02 36 00 Safeway Storage
 02 37 00 Safeway Produce Whse (door)
 02 37 01 Safeway (produce)
 thru 05
 02 38 00 Safeway Ice Cream-Blk Plastic (door)
 02 38 01 Safeways (ice cream) (door)
 02 38 02 Safeway (bulk plastic) (door)
 02 74 00 Lincoln Lead Track

06

C.E. NO. 11805-SK Engineering & Technology Development 4/92

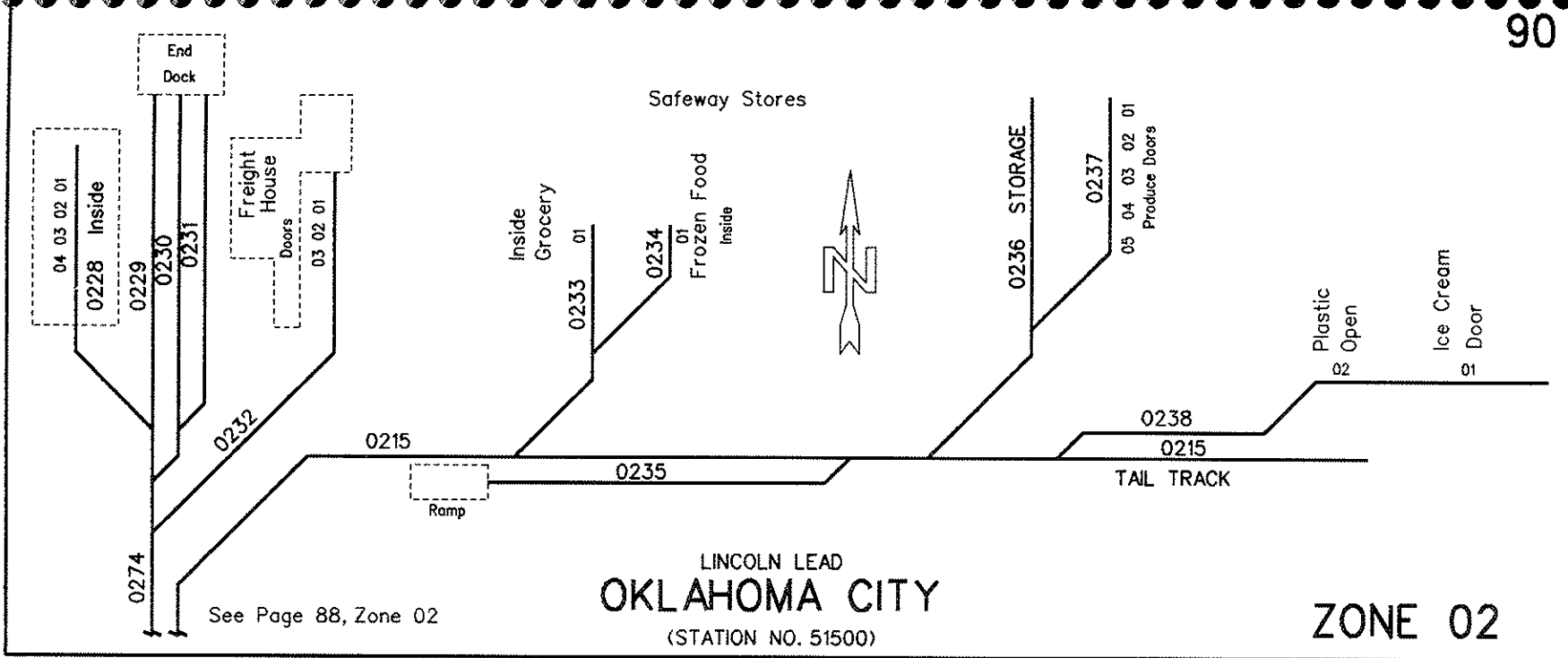

Zone 06 (Oklahoma City 51500) Oklahoma Subdivision

06 48 00 Wall Track
06 98 00 South Main Track (EBML)
06 99 00 North Main Track (WBML)

Page 91

C.E. NO. 11805-SK Engineering & Technology Development 4/92

92

92

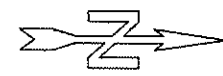
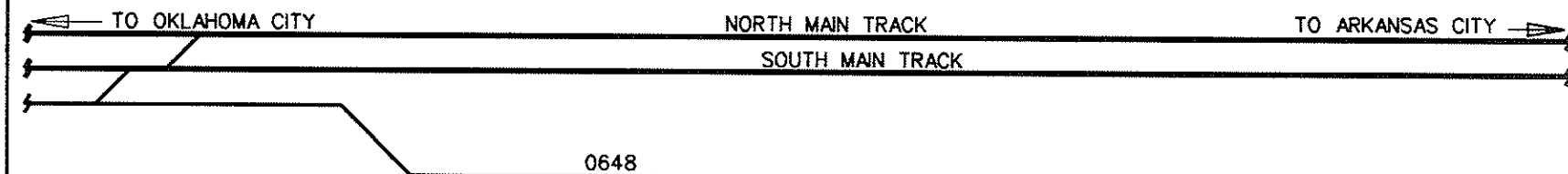

DOWNTOWN
OKLAHOMA CITY
(STATION NO. 51500)

ZONE 06

Zone 06 (Oklahoma City 51500) Oklahoma Subdivision

- 06 04 00 Dwtm Trk No. 4
- 06 05 00 Dwtm No. 5 (MKT-OKKT Recvg)
- 06 37 00 Bunte Candy
- 06 37 01 Bunte Candy (open)
- thru 02
- 06 37 10
- 06 60 00 MP Connection
- 06 61 00 MP Del'y Track
- 06 98 00 South Main Track (EBML)

Page 93

C.E.NO.11805-SK Engineering & Technology Development 4/92

94

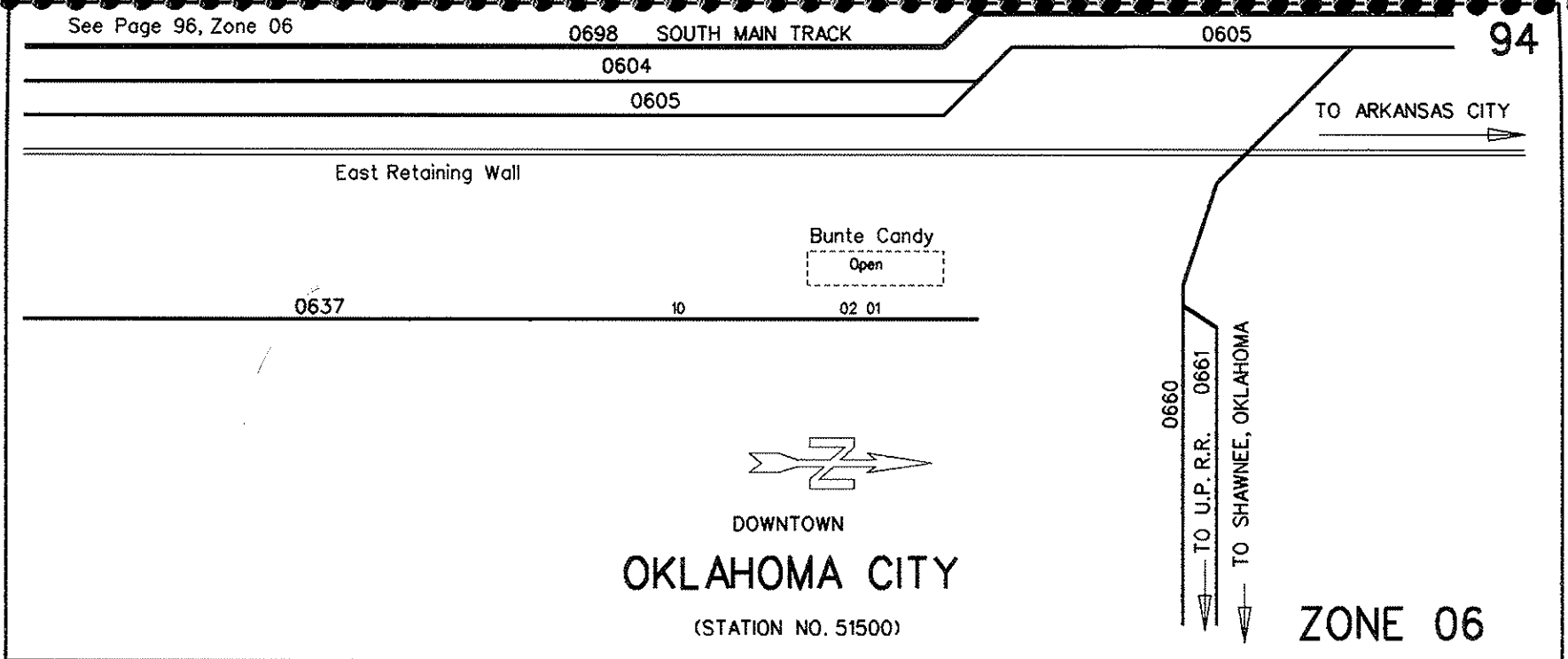

Zone 06 (Oklahoma City 51500) Oklahoma Subdivision

- 06 04 00 Dwtm Trk No. 4
- 06 05 00 MP Recvg Track
- 06 48 00 Wall Track
- 06 60 00 MP Connection
- 06 61 00 MP Del'y Track
- 06 98 00 South Main Track (EBML)
- 06 99 00 North Main Track (WBML)

Page 95

C.E. NO. 11805-SK Engineering & Technology Development 4/92

96

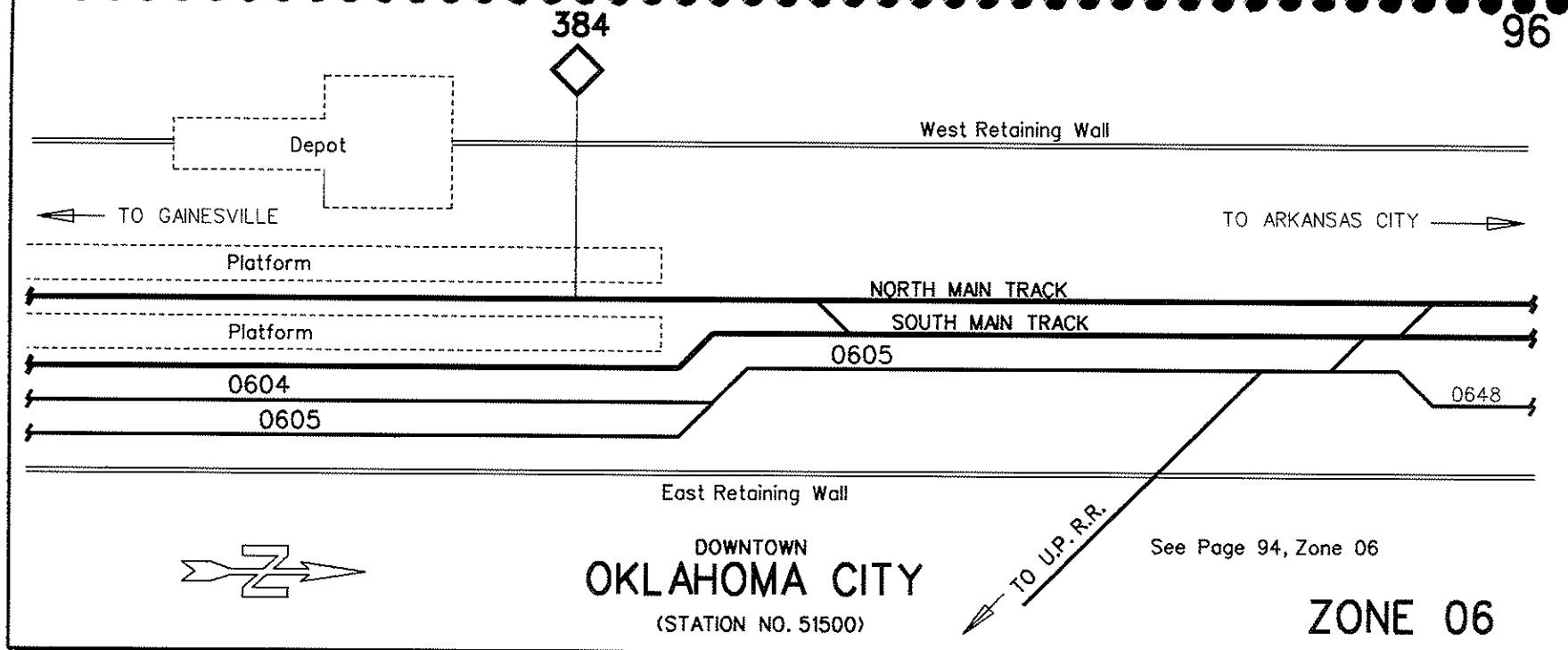

96

ZONE 06

Zone 06 (Oklahoma City 51500) Oklahoma Subdivision

- 06 04 00 Dwtm Track No. 4
- 06 05 00 Dwtm No. 5 (MKT-OKKT Recvg)
- 06 31 00 Carbo Ceramics - Team No. 2
- 06 37 00 Bunte Candy
- 06 37 00 Lumber Unloading (open)
- 06 98 00 South Main Track (EBML)
- 06 99 00 North Main Track (WBML)

Page 97

C.E.NO.11805-SK Engineering & Technology Development 4/92

98

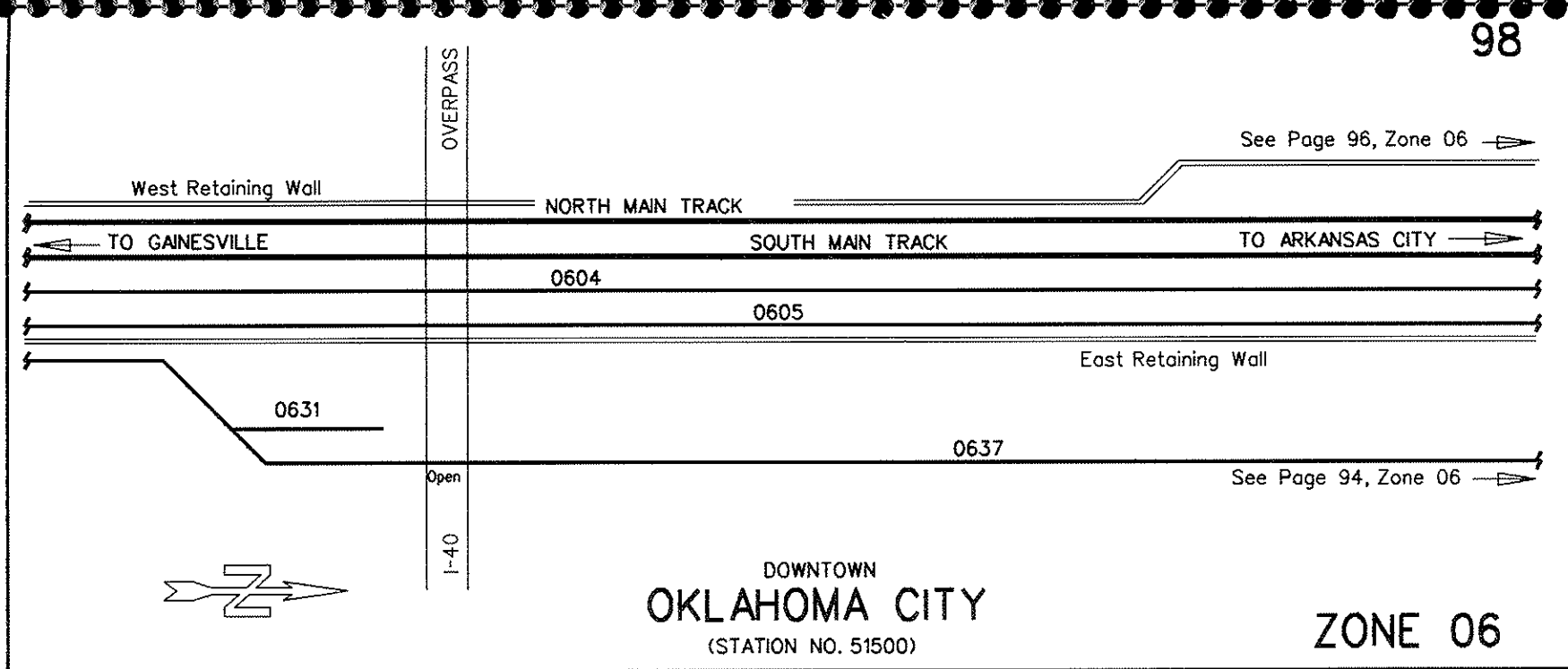

DOWNTOWN
OKLAHOMA CITY
 (STATION NO. 51500)

ZONE 06

98

Zone 08 (Oklahoma City 51500) Oklahoma Subdivision

08 01 00	Acco No. 1		08 20 00	Trinity		08 24 00	Capital Steel Track	
08 01 00	Acco Feed Mill	(door)	08 20 01	Trinity	(open)	08 24 01	Capital Steel	(open)
thru 06			thru 10			08 25 00	Capital Steel No. 1	
08 01 07	Acco Feed Mill	(open)	08 21 00	Trinity		08 25 01	Capital Steel	(open)
thru 12			08 21 01	Trinity	(open)	thru 05		
08 02 00	Acco No. 2		thru 10			08 26 00	Capital Steel No. 2	
08 02 01	Acco Feed Mill	(open)	08 22 00	Trinity		08 26 01	Capital Steel	
thru 12			08 22 01	Trinity	(open)	thru 05		
08 03 00	Acco Stge No. 1		thru 10			08 27 00	Packingtown Pass No. 1	
08 04 00	Acco Stge No. 2		08 23 00	Trinity-City Garage		08 28 00	Packingtown Pass No. 2	
08 19 00	Trinity		08 23 01	Trinity	(open)	06 98 00	South Main Trk (EBML)	
08 19 01	Trinity	(open)	thru 03			06 99 00	North Main Trk (WBML)	
thru 10			08 23 11	City Garage	(open)			

C.E. NO. 11805-SK Engineering & Technology Development 4/92

100

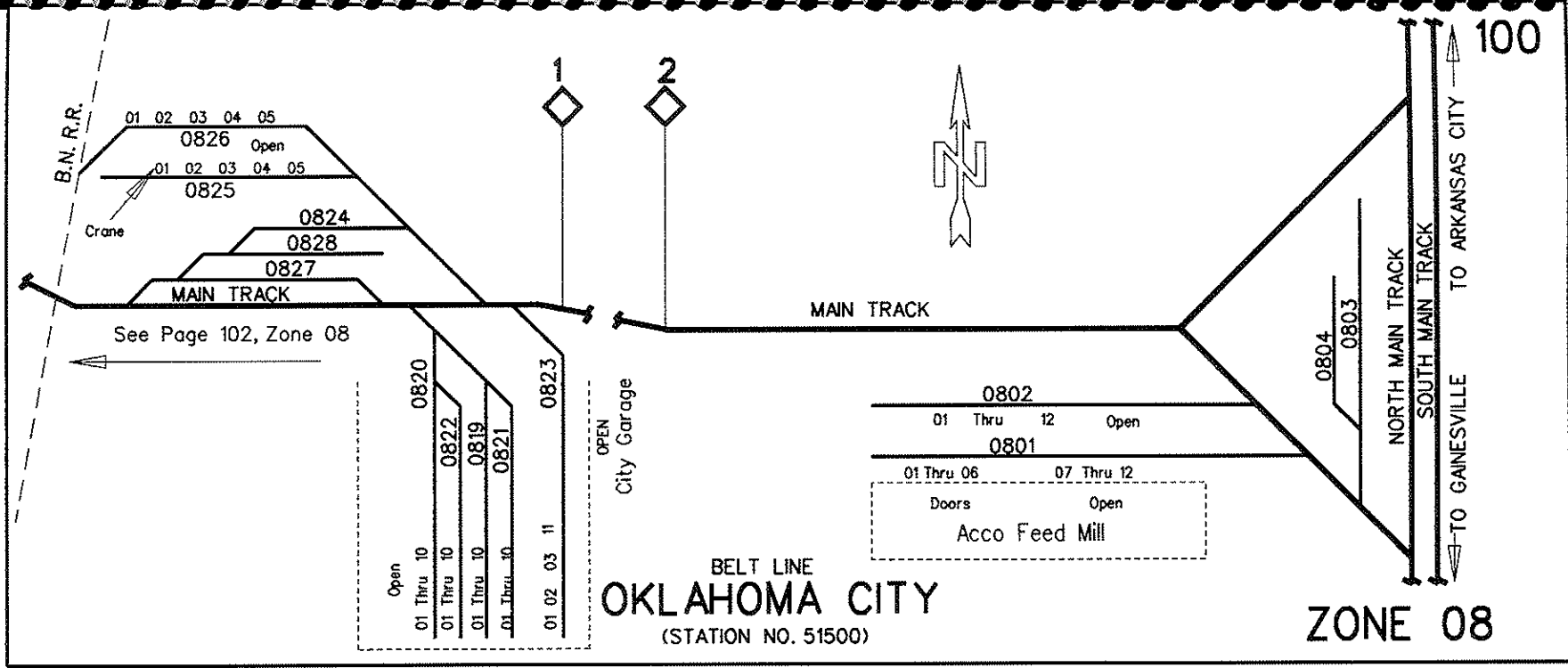

BELT LINE
OKLAHOMA CITY
 (STATION NO. 51500)

ZONE 08

Zone 08 (Oklahoma City 51500) Belt Line

08 30 00	Capital City Tsfr - Lincoln Elec		08 51 00	Wilson No. 11
08 30 01	Capital City Transfer	(door)	08 60 00	Sheffield Steel
08 30 10	Lincoln Electric Co	(door)	08 60 01	Sheffield Steel
08 31 00	Paxton Lbr			(open)
08 32 00	Team Track Patrons	(open)	thru 03	
08 43 00	Wilson No. 3		08 77 00	Packingtown Yard No. 7
08 44 00	Wilson No. 4		08 78 00	Packingtown Yard No. 8
08 45 00	Wilson No. 5		08 79 00	Packingtown Yard No. 9
			08 80 00	Packingtown Yard No. 10

C.E.NO.11805-SK Engineering & Technology Development 4/92

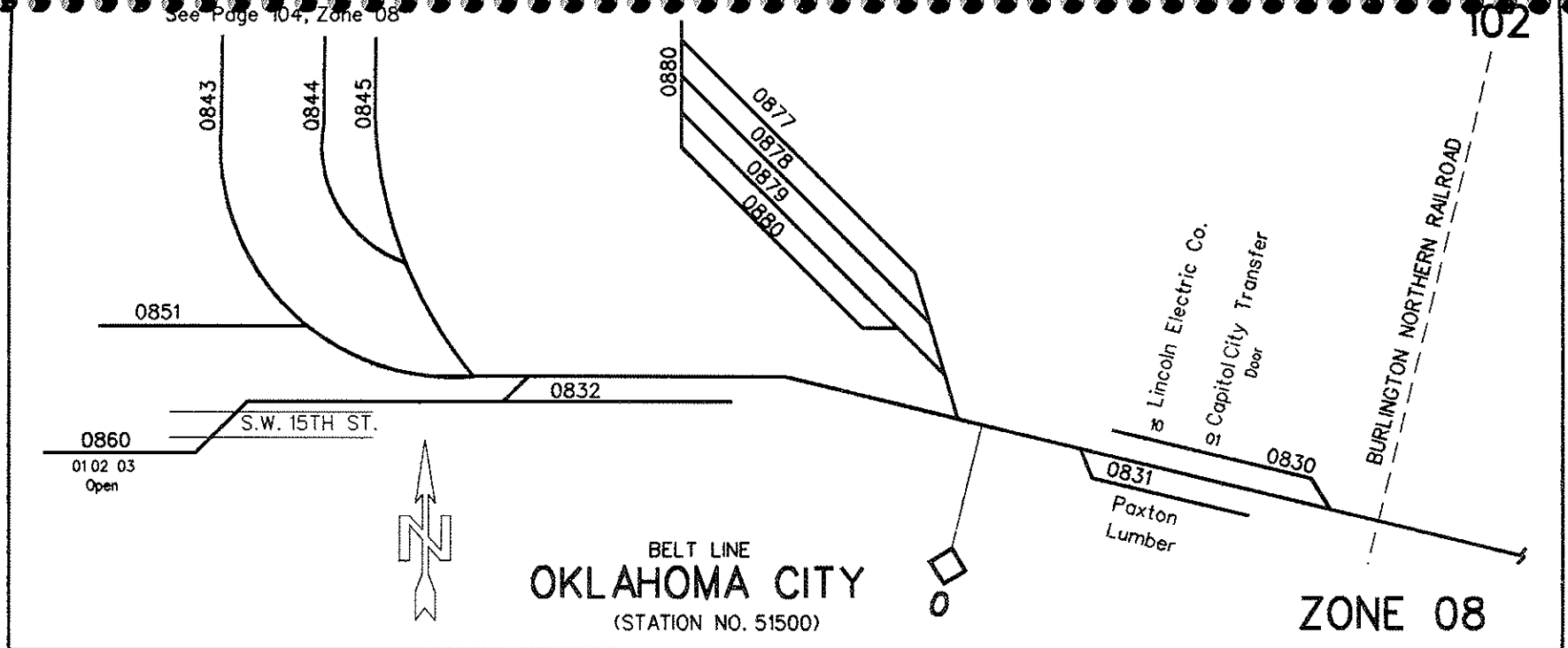

Zone 06 (Oklahoma City 51500) Oklahoma Subdivision

- 06 02 00 Dwtn Trk No. 2
- 06 03 00 Dwtn Trk No. 3
- 06 04 00 Dwtn Trk No. 4
- 06 05 00 Dwtn No. 5 (MKT-OKKT Recvg)
- 06 31 00 Carbo Ceramics - Team No. 2
- 06 31 00 Team Track Patrons (dock)
- 06 80 00 BN Receiving Track
- 06 81 00 BN Del'y Track
- 06 98 00 South Main Track (EBML)
- 06 99 00 North Main Track (WBML)

Page 103

C. ENO.11805-SK Engineering & Technology Development 4/92

104

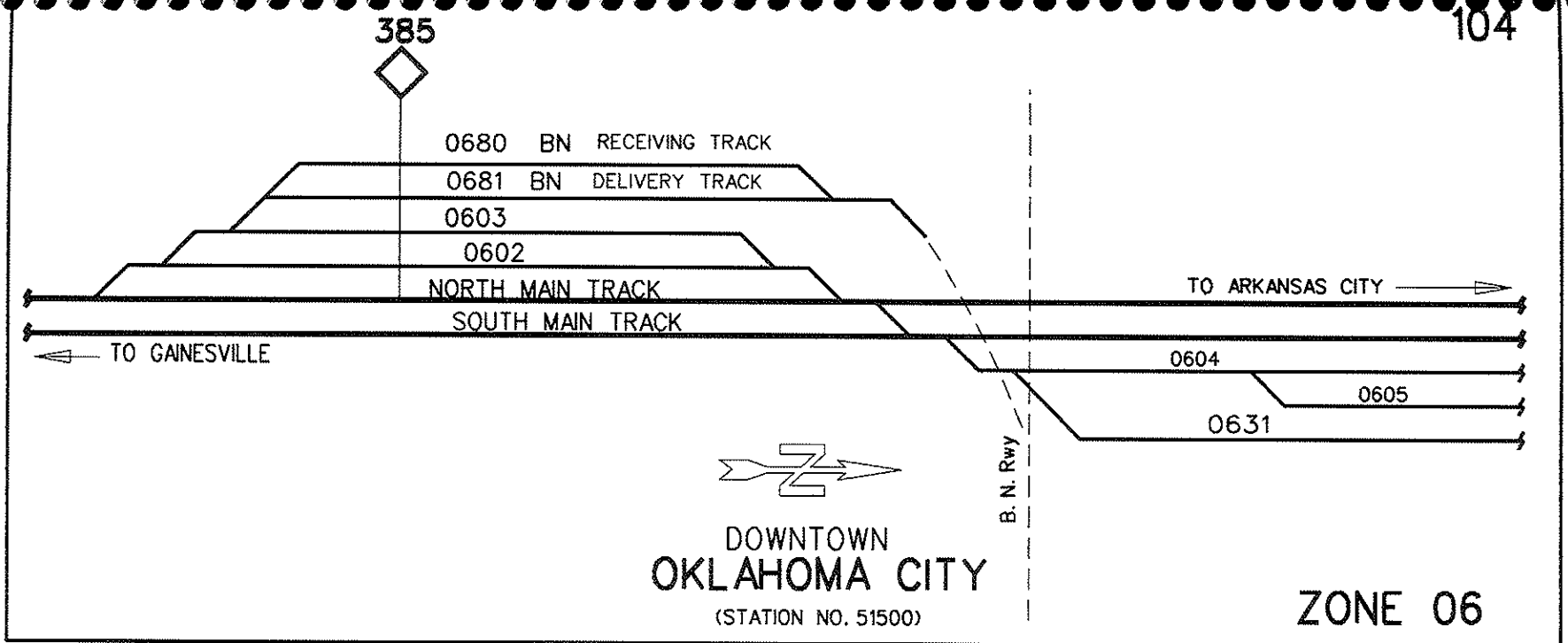

104

ZONE 06

Zone 07 (Oklahoma City 51500) Oklahoma Subdivision

07 05 00	Old Levitz Spur	
07 09 00	Scrivner	
07 09 01	Scrivner	(open)
thru 03		
07 10 00	Scrivner Lead	
07 98 00	South Main Track (EBML)	
07 99 00	North Main Track (WBML)	

Page 105

C.E. NO. 11805-SK Engineering & Technology Development 4/92

106

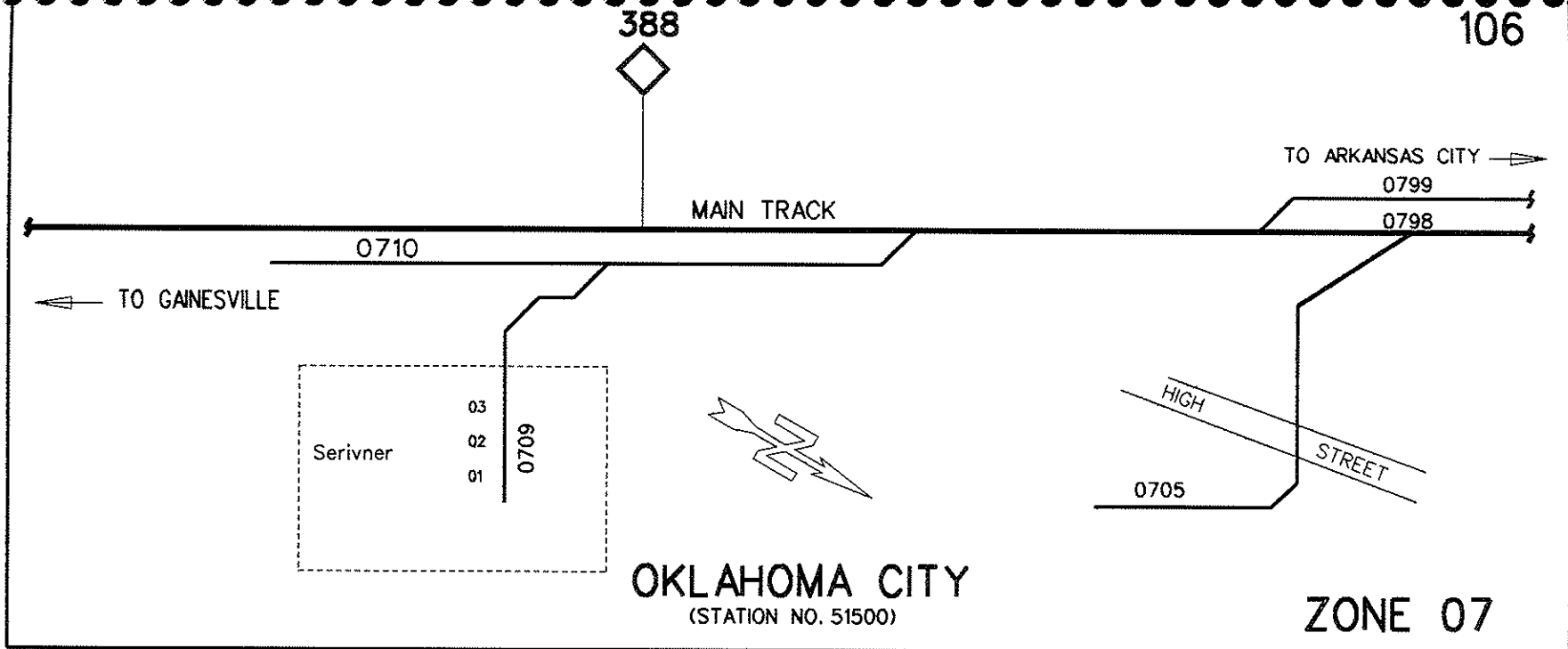

Zone 05 (Flynn 51500) Oklahoma Subdivision

05 05 00 Flynn Team - Vista Polymer
 05 05 01 Vista Polymers (open)
 05 05 30 Team Track Patrons (open)
 thru 35
 05 06 00 West Leg of Wye
 05 99 00 Main Track

C.E. NO. 11805-SK Engineering & Technology Development 4/92

108

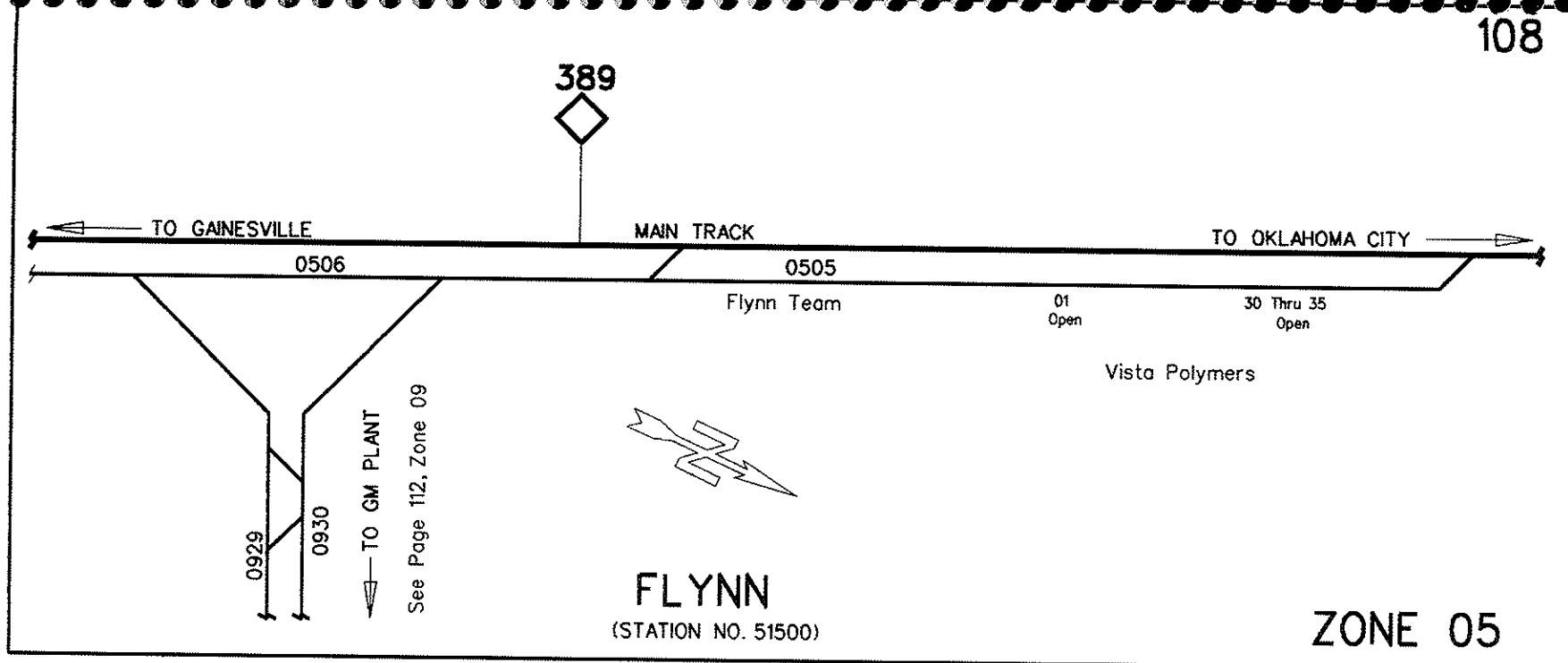

See Page 112, Zone 09

FLYNN
 (STATION NO. 51500)

ZONE 05

Zone 05 (Flynn 51500) Oklahoma Subdivision

05 20 00	OG&E (Flynn)		05 28 00	Locke Plumbing Lead	
05 20 01	OG&E Pole Yard	(open)	05 29 00	Locke Plumbing Lead	
thru 03			05 32 00	Star Mfg. Co	
05 21 00	OG&E (Flynn)		05 32 01	Star Manufacturing Co	(open)
05 21 01	OG&E	(dock)	thru 06		
thru 02			05 33 00	Star Mgf. Co.	
05 21 03	OG&E		05 33 01	Star Manufacturing Co.	(inside)
05 22 00	OG&E (Flynn)		05 33 02	Star Manufacturing Co.	(open)
05 21 00	OG&E	(open)	05 34 00	MBM Midwest	
05 25 00	Crowley Tar		05 34 01	MBM Inc	(door)
05 25 01	Crowley Tar	(rack)	thru 04		
thru 03			05 35 00	Lead	
05 25 04	Crowley Tar	(hose)	05 99 00	Main Track	
thru 07					

C.E. NO. 11805-SK Engineering & Technology Development 4/92

110

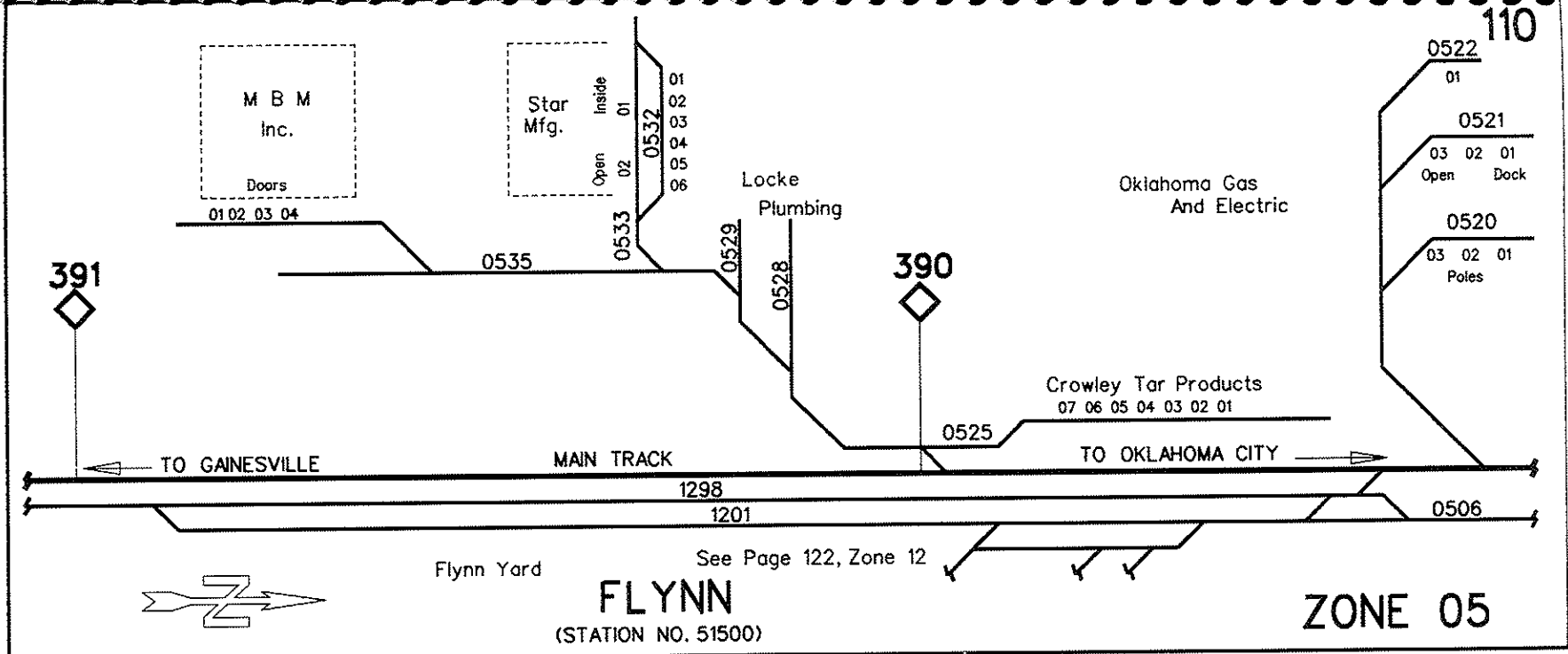

Zone 09 (Flynn 51500) Oklahoma Subdivision

09 03 00	Sooner Road Siding		09 15 00	Weyerhaeuser	
09 04 00	Dolese Siding		09 15 01	Weyerhaeuser	(door)
09 05 00	Sunnylane Team		thru 03		
09 05 01	Team Track Patrons	(open)	09 16 00	Payless OKC	
09 08 00	Carlton Div Lam Storage		09 16 01	Payless Cashway	(open)
09 12 00	International Paper		09 27 00	Eighty Four Lbr	
09 12 01	Vacant	(open)	09 27 01	Vacant	(open)
09 14 00	Weyerhaeuser Spur		09 29 00	Flynn Lead South Track	
09 14 01	Weyerhaeuser	(dock)	09 30 00	Flynn Lead North Track	
thru 02			13 01 00	Saddleback Unldg	
09 14 03	Weyerhaeuser	(open)	13 20 00	J&S Paper	
thru 04					

C.E. NO. 11805-SK Engineering & Technology Development 4/92

112

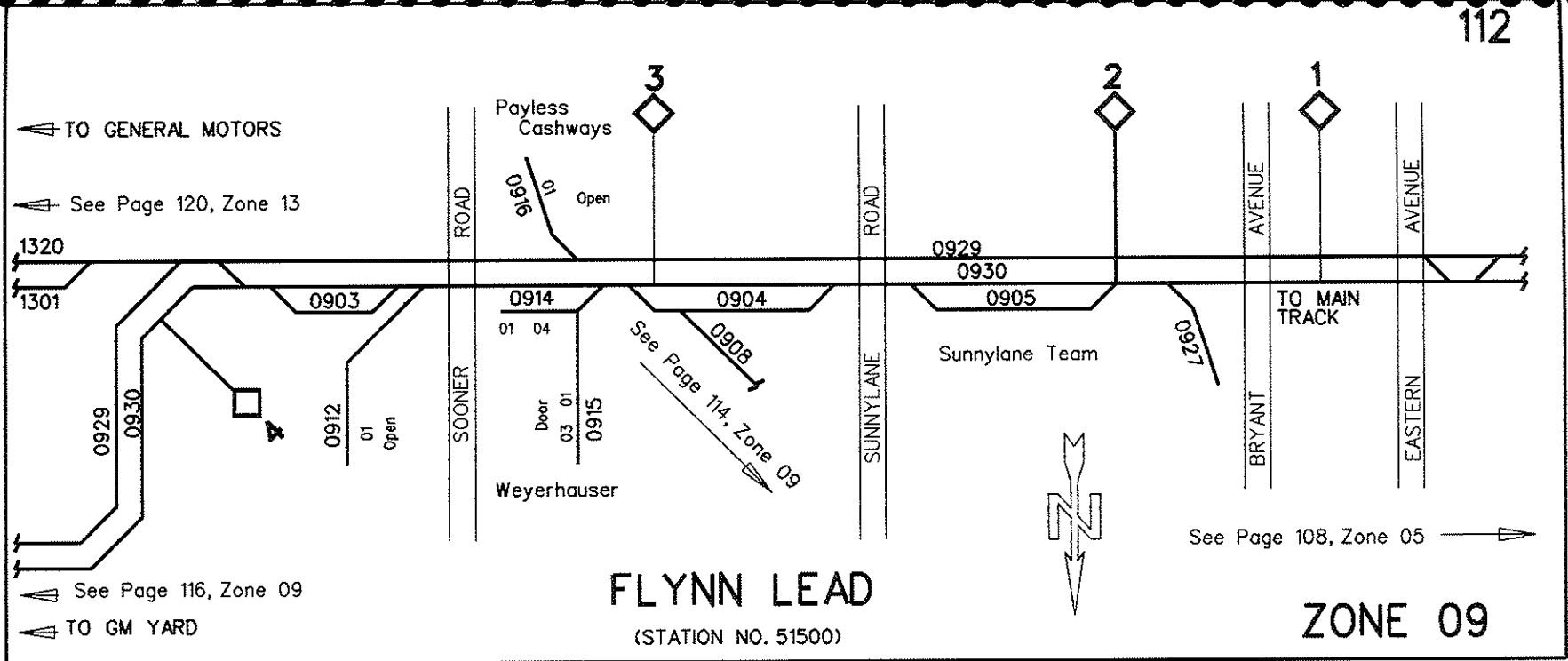

112

FLYNN LEAD
(STATION NO. 51500)

ZONE 09

Zone 09 (Flynn 51500) Oklahoma Subdivision

09 04 00	Dolese Siding		09 11 00	Vista Polymer No. 1	
09 08 00	Carlton Div Lam Storage		09 11 01	Vista Polymer	(oh rack)
09 09 00	Vista Polymer No. 3		thru 03		
09 09 01	Vista Polymer	(oh loading)	09 13 00	Carlton Div Lam	
thru 08			09 13 01	Carlton Products	(ut pit)
09 10 00	Vista Polymer No. 2		09 13 02	Carlton Products	(spout)
09 10 01	Vista Polymer		thru 03		
thru 03			09 13 04	Carlton Products	(dock)
			09 17 00	Vista Polymers Stge 1	
			09 18 00	Vista Polymers Stge 2	

See Page 112, Zone 09

C.E. NO. 11805-SK Engineering & Technology Development 4/92

114

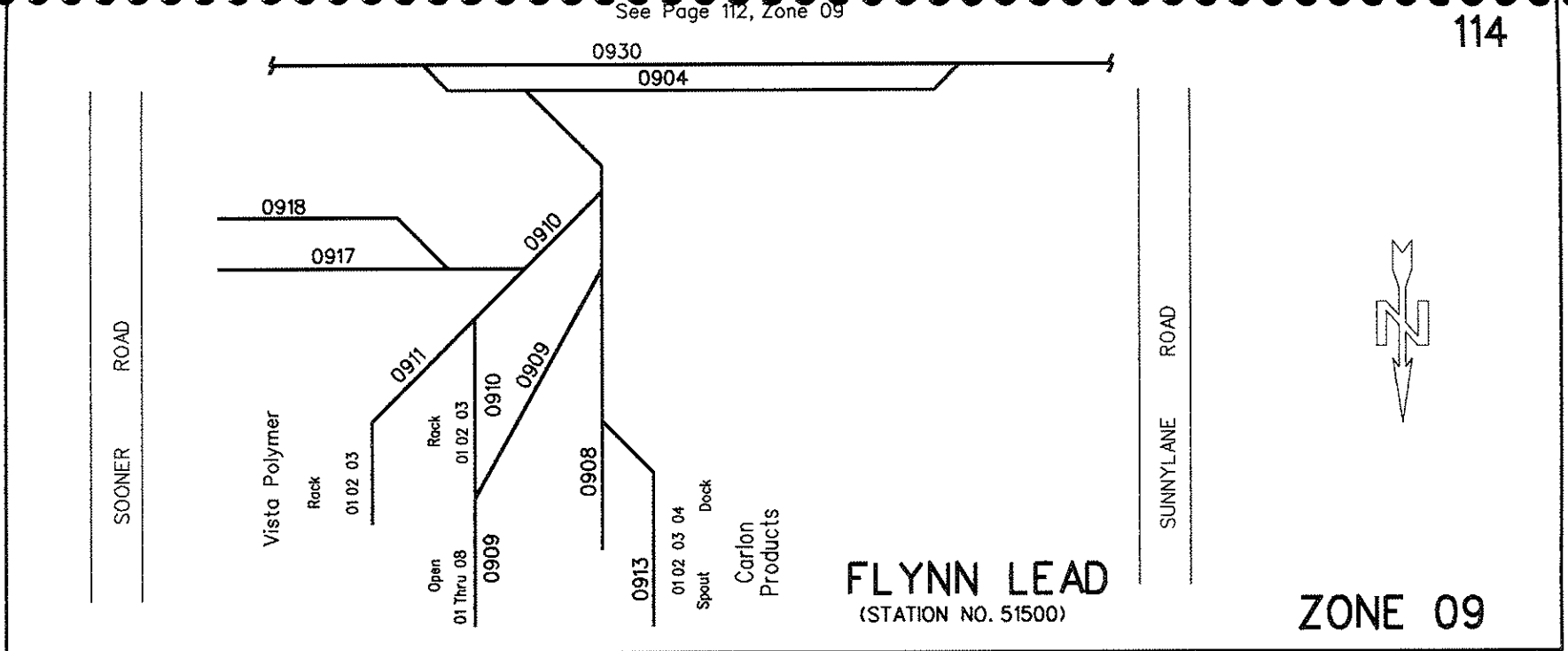

114

FLYNN LEAD
(STATION NO. 51500)

ZONE 09

Zone 90 (Flynn 51500) ATSF GM Yard

09 29 00	Flynn Lead South Track	09 40 00	South Yd No. 10	09 56 00	North Yd No. 7
09 30 00	Flynn Lead North Track	09 41 00	South Yd No. 11	09 57 00	North Yd No. 8
09 31 00	South Yd No. 1	09 42 00	South Yd No. 12	09 58 00	North Yd No. 9
09 32 00	South Yd No. 2	09 43 00	South Yd No. 13	09 59 00	North Yd No. 10
09 33 00	South Yd No. 3	09 44 00	OKC GMAD South Yd No. 14	09 60 00	North Yd No. 11
09 34 00	South Yd No. 4	09 50 00	North Yd No. 1	09 61 00	North Yd No. 12
09 35 00	South Yd No. 5	09 51 00	North Yd No. 2	09 62 00	OKC GMAD North Yd No. 13
09 36 00	South Yd No. 6	09 52 00	North Yd No. 3	09 65 00	Fuel Track No. 1
09 37 00	South Yd No. 7	09 53 00	North Yd No. 4	09 66 00	Fuel Track No. 2
09 38 00	South Yd No. 8	09 54 00	North Yd No. 5	09 67 00	GM Bad Order Track
09 39 00	South Yd No. 9	09 55 00	North Yd No. 6	09 77 00	Tri-level Ldg Trk No. 7
				09 82 00	GMAD No. 2

C.E. NO. 11805-SK Engineering & Technology Development 4/92

116

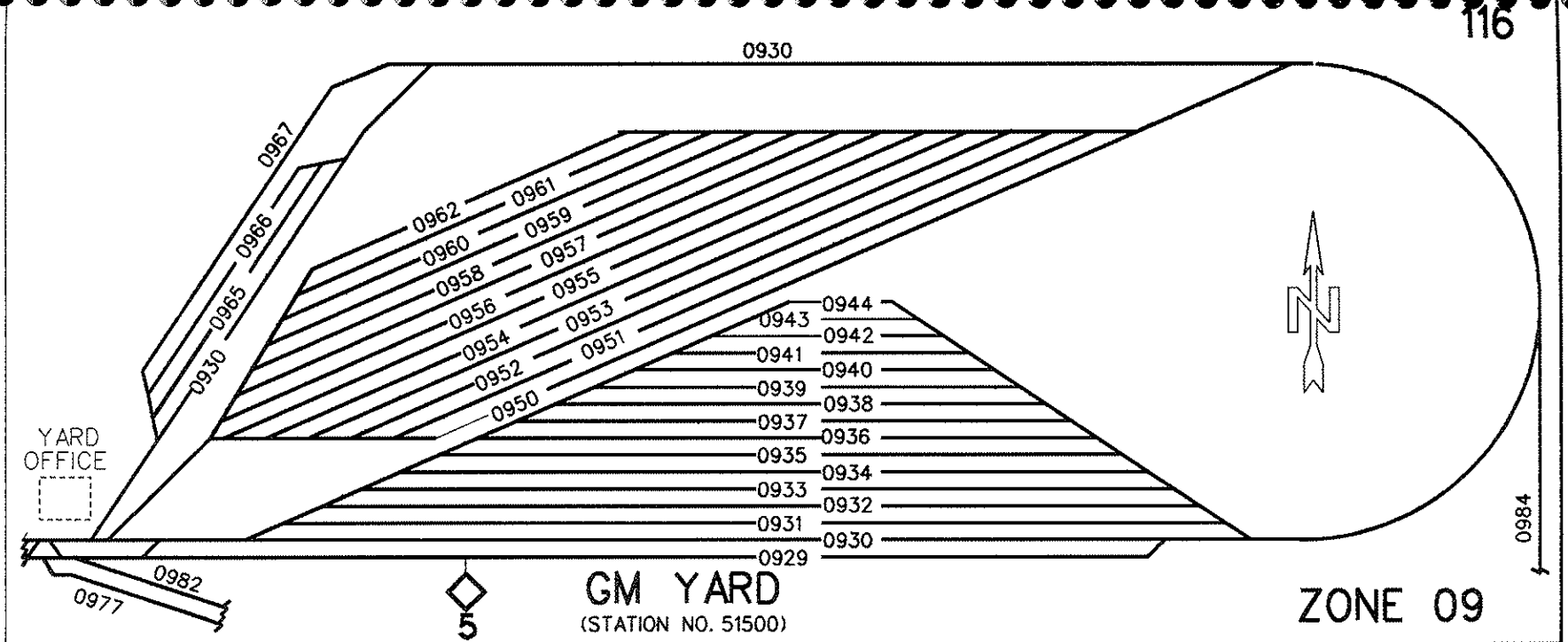

Zone 09 (Flynn 51500) Oklahoma Subdivision

09 71 00	Tri-level Ldg Track No. 1		09 82 00	GMAD No. 2 Track	(inside)
09 72 00	Tri-level Ldg Track No. 2		09 83 00	GMAD No. 3 Track	(inside)
09 73 00	Tri-level Ldg Track No. 3		09 84 00	GMAD No. 4 Track	(inside)
09 74 00	Tri-level Ldg Track No. 4		09 85 00	GMAD No. 5 Track	(inside)
09 75 00	Tri-level Ldg Track No. 5		09 86 00	GMAD No. 6 Track	(open)
09 76 00	Tri-level Ldg Track No. 6		09 87 00	GMAD No. 7 Track	(open)
09 77 00	Tri-level Ldg Track No. 7		09 88 00	GMAD No. 8 Track	(open)
09 81 00	GMAD No. 1 Track	(inside)	09 89 00	GMAD Runaround	
			09 90 00	GMAD No. 10	(coal unldg)

C.E. NO. 11805-SK Engineering & Technology Development 4/92

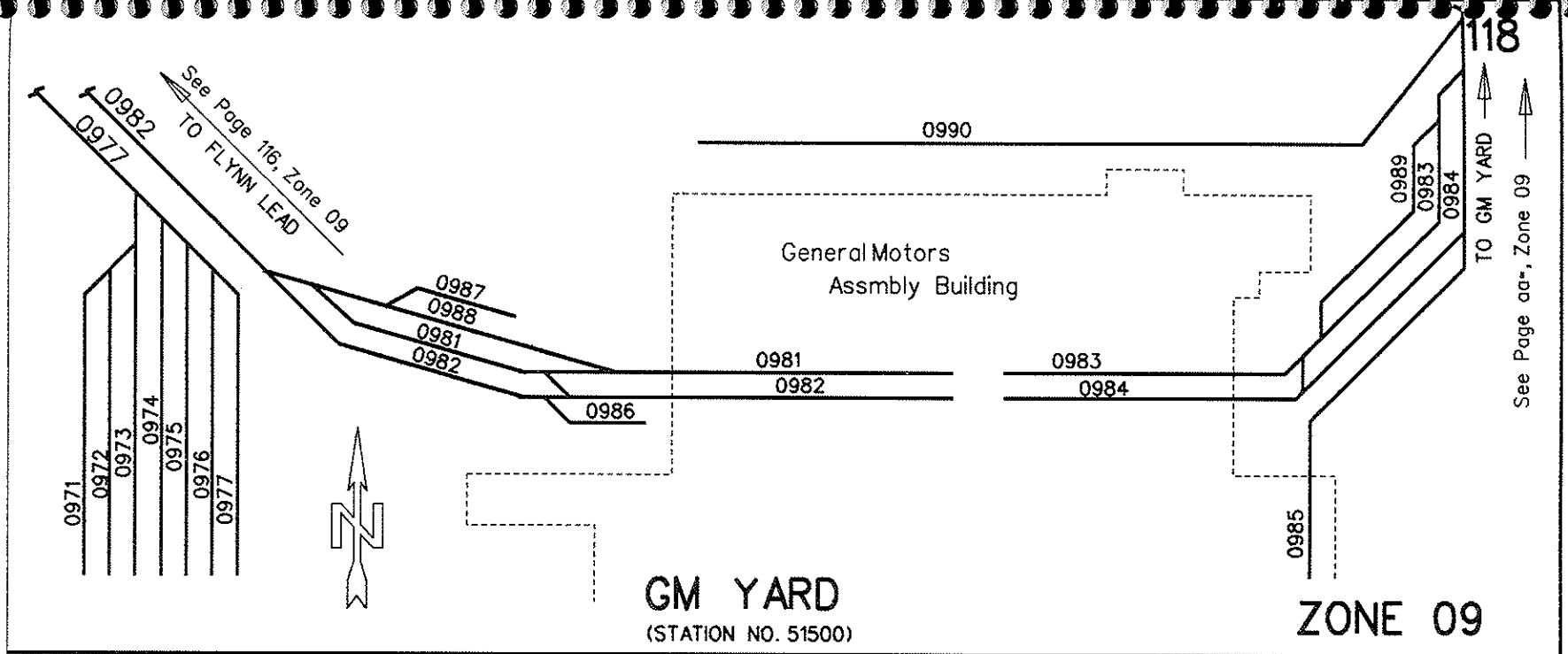

Zone 13 (Flynn 51500) Oklahoma Subdivision

09 29 00	Flynn Lead South Track	
09 30 00	Flynn Lead North Track	
13 01 00	Multi-level Unldg	
13 02 00	Multi-level Unldg	
13 03 00	Multi-level Unldg	
13 04 00	Multi-level Unldg	
13 05 00	Multi-level Unldg	
13 06 00	Multi-level Unldg	
13 20 00	J & S Paper	
13 20 01	J & S Paper Co.	(open)
13 21 00	Southwest Elec	
13 21 01	Southwest Electric Co.	(hose)
13 21 02	Southwest Electric Co.	(hoist)

Page 119

C.E. NO. 11805-SK Engineering & Technology Development 4/92

120

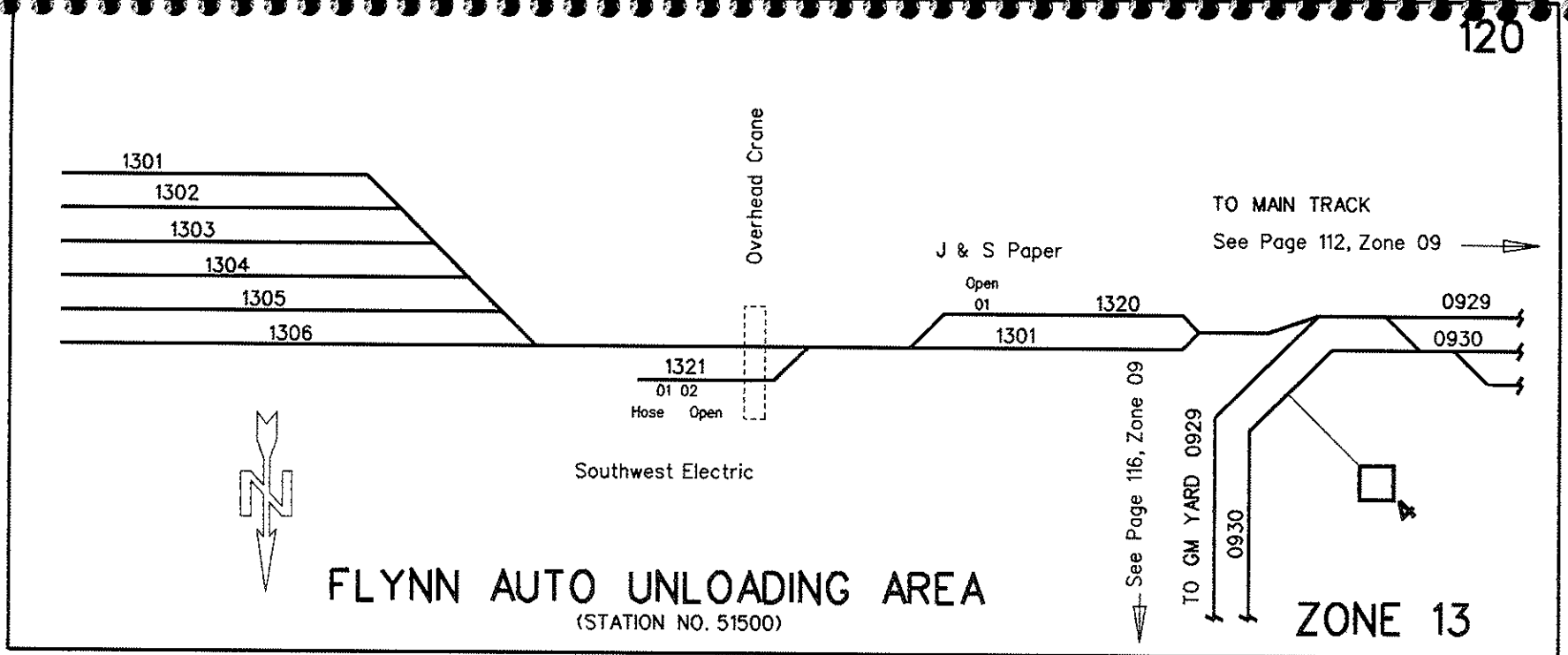

Zone 12 (Flynn 51500) Oklahoma Subdivision

12 01 00	R&D No. 1	12 33 00	Bowl No. 3
12 02 00	R&D No. 2	12 34 00	Bowl No. 4
12 03 00	R&D No. 3	12 35 00	Bowl No. 5
12 04 00	R&D No. 4	12 36 00	Bowl No. 6
12 05 00	R&D No. 5	12 37 00	Bowl No. 7
12 06 00	Eng. Service Track	12 38 00	Bowl No. 8
12 29 00	Crossover	12 60 00	North Pocket
12 31 00	Bowl No. 1	12 96 00	TOFC No. 1
12 32 00	Bowl No. 2	12 97 00	TOFC No. 2
		12 98 00	Siding
		12 99 00	Main Track

Page 121

C.E. NO. 11806-SK Engineering & Technology Development 4/92

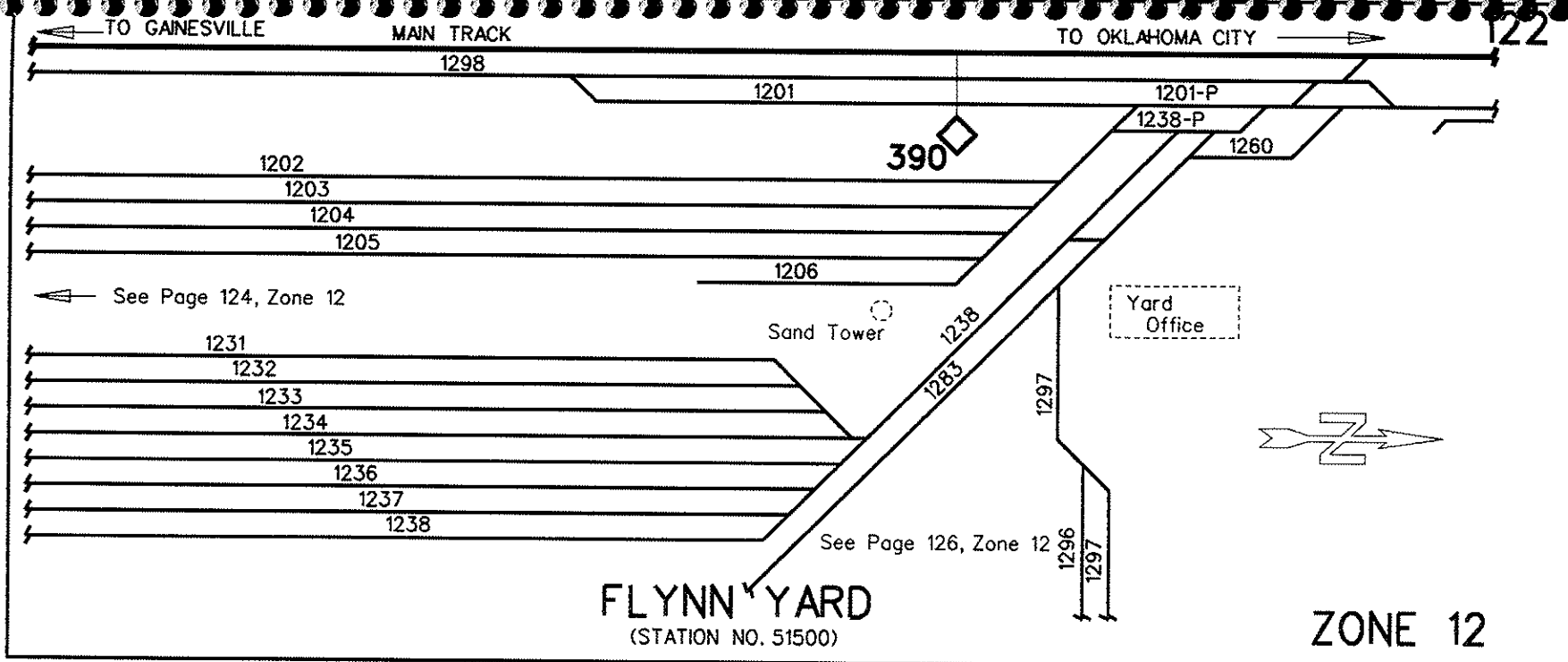

Zone 12 (Flynn 51500) Oklahoma Subdivision

12 02 00	R&D No. 2	12 33 00	Bowl No. 3
12 03 00	R&D No. 3	12 34 00	Bowl No. 4
12 04 00	R&D No. 4	12 35 00	Bowl No. 5
12 05 00	R&D No. 5	12 36 00	Bowl No. 6
12 20 00	Hump Set/Out Trk	12 37 00	Bowl No. 7
12 21 00	Scale Track	12 38 00	Bowl No. 8
12 30 00	Hump Lead	12 83 00	Rip Track Lead
12 31 00	Bowl No. 1	12 91 00	Flynn Team Track
12 32 00	Bowl No. 2	12 98 00	Siding
		12 99 00	Main Track

C.E. NO. 11806-SK Engineering & Technology Development 4/92

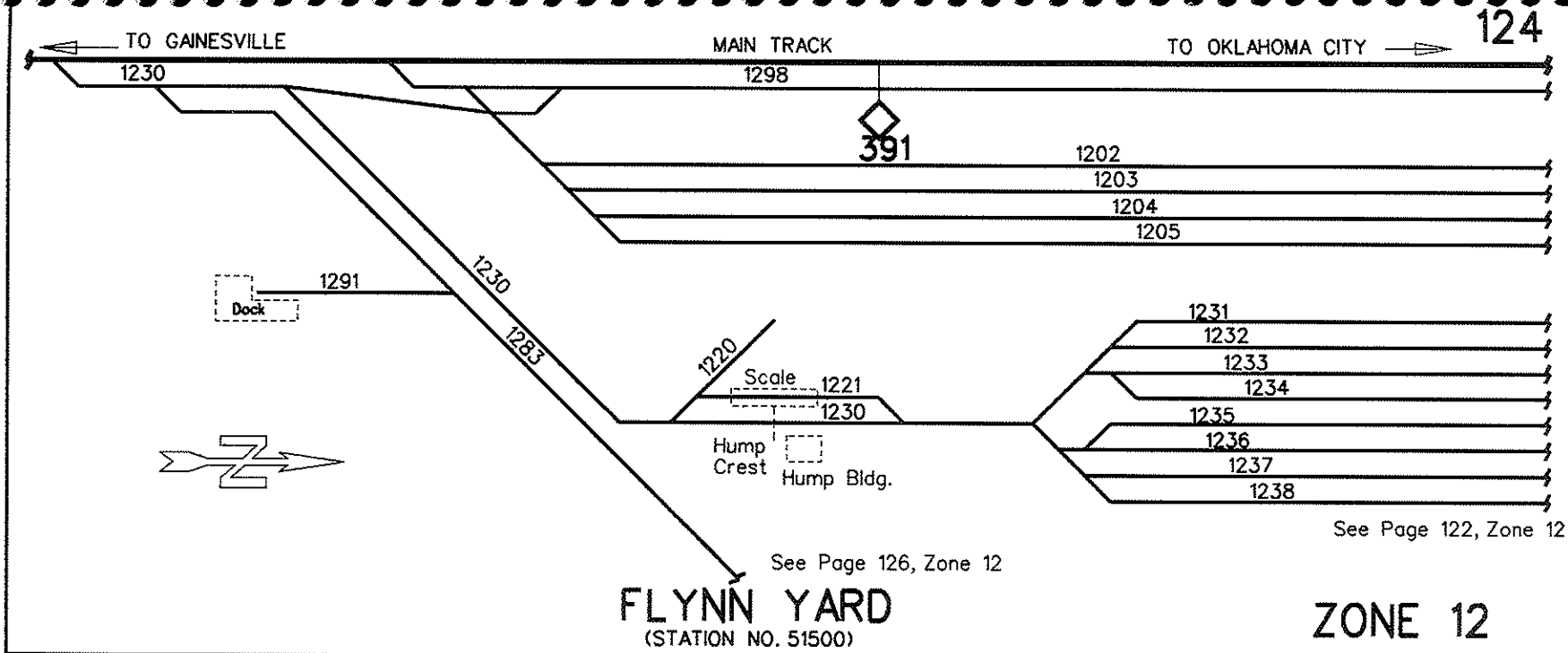

124

124

See Page 122, Zone 12

FLYNN YARD
(STATION NO. 51500)

ZONE 12

Zone 12 (Flynn 51500) Oklahoma Subdivision

- 12 77 00 Bunk Car Spur
- 12 78 00 Hvy Rpr Trk
- 12 79 00 One Spot No. 1
- 12 80 00 One Spot No. 2
- 12 81 00 Supply Track
- 12 81 01 Supplies (ramp/dock)
- 12 82 00 Conditioning Track
- 12 83 00 Rip Track Lead
- 12 91 00 Flynn Team Track
- 12 96 00 TOFC No. 1
- 12 97 00 TOFC No. 2

Page 125

C.E. NO. 11806-SK Engineering & Technology Development 4/92

126

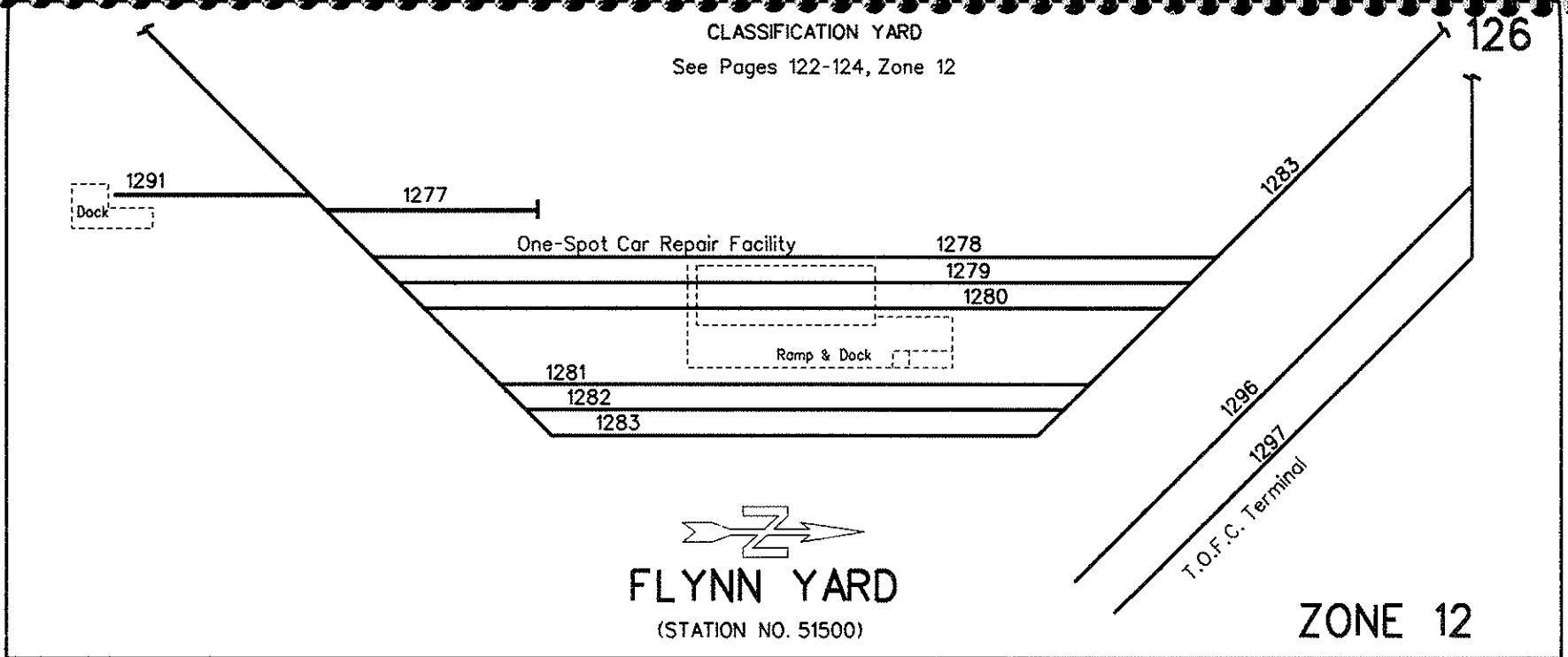

Zone 05 (Moore 51420) Oklahoma Subdivision

05 50 00	Diamond Salt - Builders Supply	
05 50 01	Diamond Salt Co.	(inside)
05 56 00	Moore Team - Hoffman Furniture	
05 58 00	Moore Siding	(dock)
05 99 00	Main Track	

Page 127

C.E. NO. 11806-SK Engineering & Technology Development 4/92

128

128

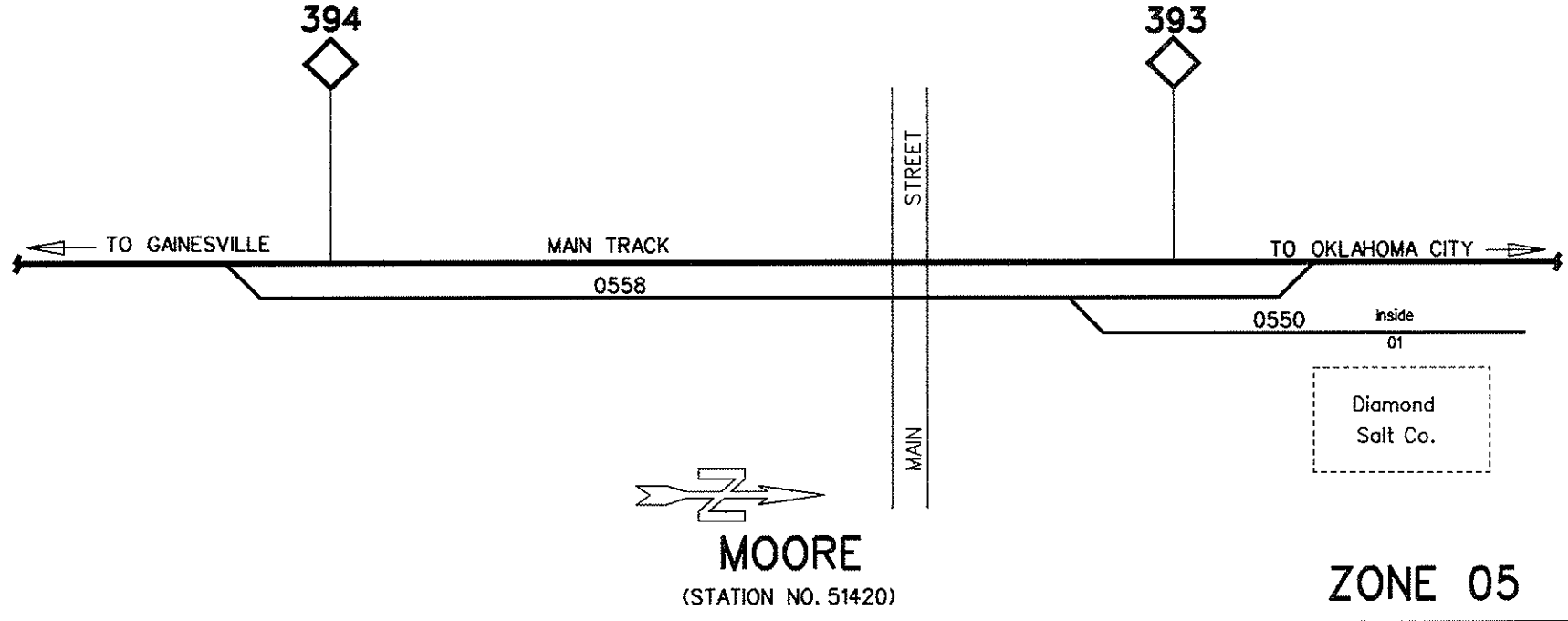

Zone 05 (Norman 51415) Oklahoma Subdivision

05 78 00	Normal Siding	
05 81 00	Coors Central	
05 81 01	Coors Central	(dock)
thru 02		
05 99 00	Main Track	

Page 129

130

C.E. NO. 11806-SK Engineering & Technology Development 4/92

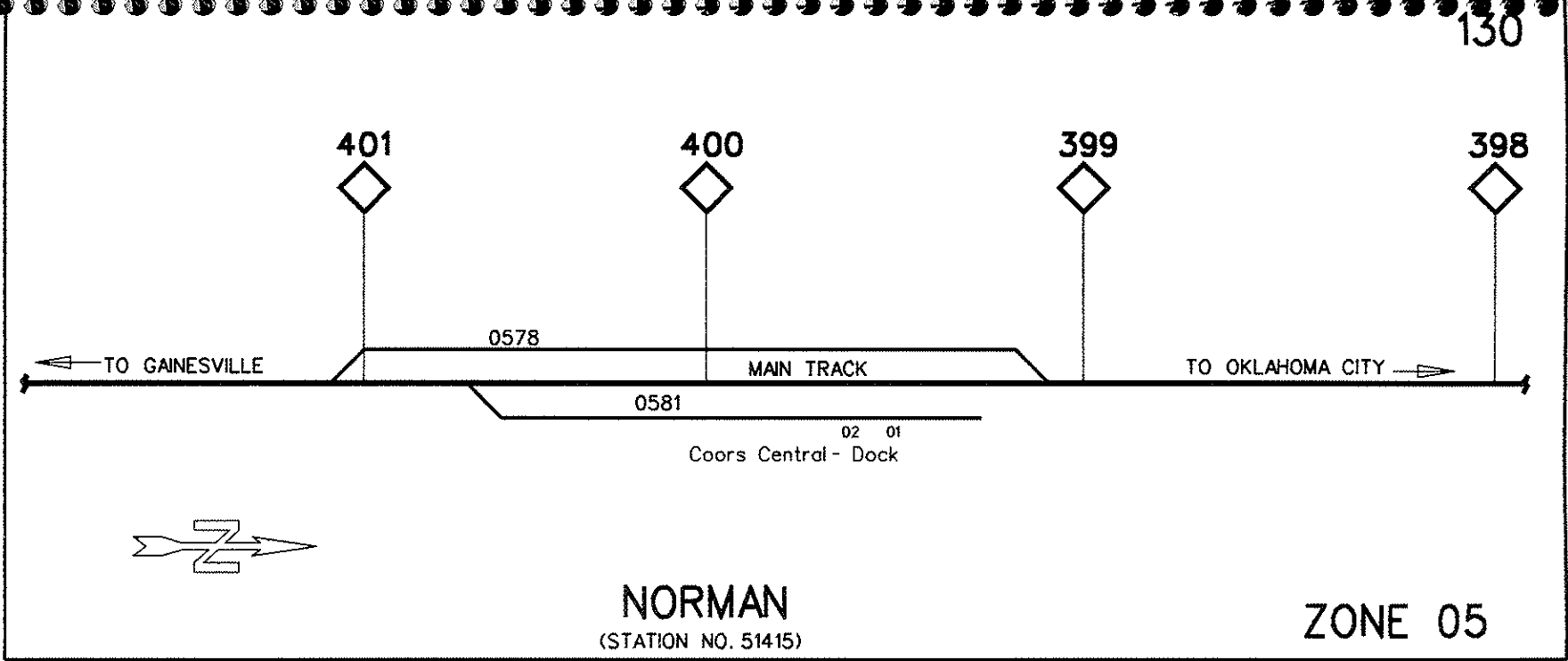

NORMAN
(STATION NO. 51415)

ZONE 05

Zone 05 (Norman 51415) Oklahoma Subdivision

05 83 00	Univ of Okla (Old West Team)	
05 83 01	University of Oklahoma	(dock)
05 88 00	Storage No. 2	
05 99 00	Main Track	(open)

Page 131

C.E. NO. 11806-SK Engineering & Technology Development 4/92

132

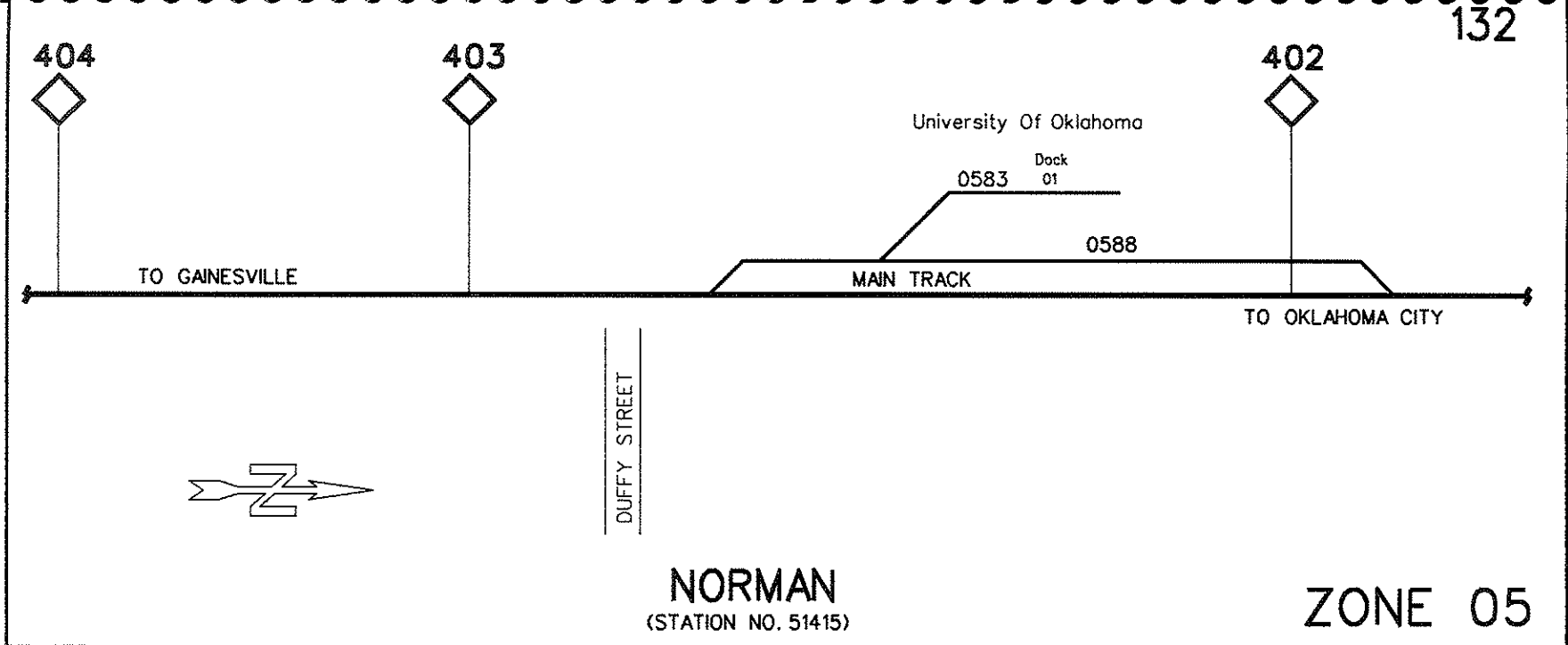

NORMAN
(STATION NO. 51415)

ZONE 05

Zone 05 (Nobel 51410) Oklahoma Subdivision

05 97 00 Noble Team
05 98 00 Noble Siding (9075 ft)
05 99 00 Main Track

Page 133

C.E. NO. 11806-SK Engineering & Technology Development 4/92

134

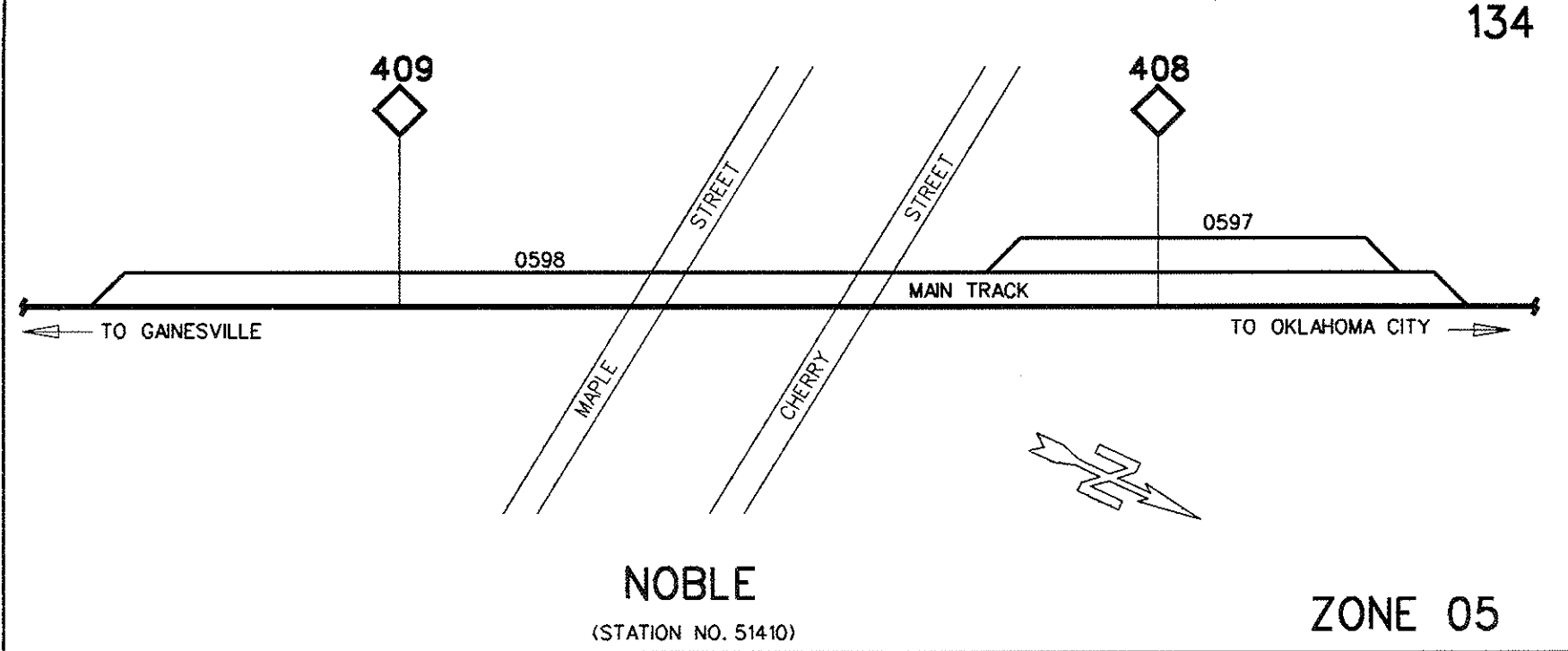

134

ZONE 05

Zone 41 (Purcell 51400) Oklahoma Subdivision

- 41 03 00 Yard Track No. 3
- 41 05 00 Yard Track No. 5
- 41 08 00 Yard Track No. 8
- 41 09 00 Yard Track No. 8 Extension
- 41 14 00 Old West Yd Lead - Purcell Feed
- 41 98 00 Purcell Siding
- 41 99 00 Main Track

Page 135

C.E. NO. 11806-SK Engineering & Technology Development 4/92

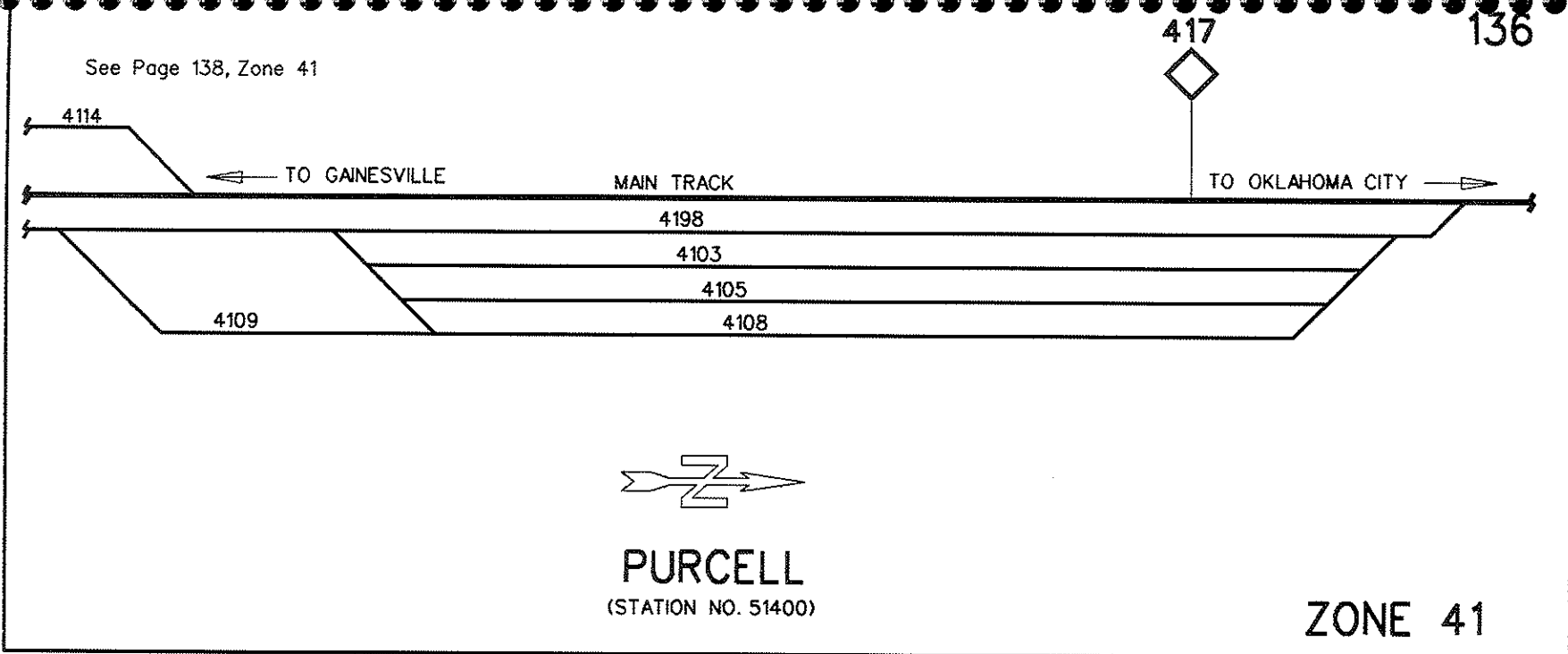

136

Zone 41 (Purcell 51400) Oklahoma Subdivision

- 41 09 00 Yard Track No. 8 Extension
- 41 14 00 Old West Yd Lead - Purcell Feed
- 41 14 01 Purcell Seed & Grain Co (spout)
- thru 02
- 41 14 03 Purcell Seed & Grain Co. (open)
- 41 98 00 Purcell Siding
- 41 99 00 Purcell Main Track

Page 137

C.E. NO. 11806-SK Engineering & Technology Development 4/92

138

138

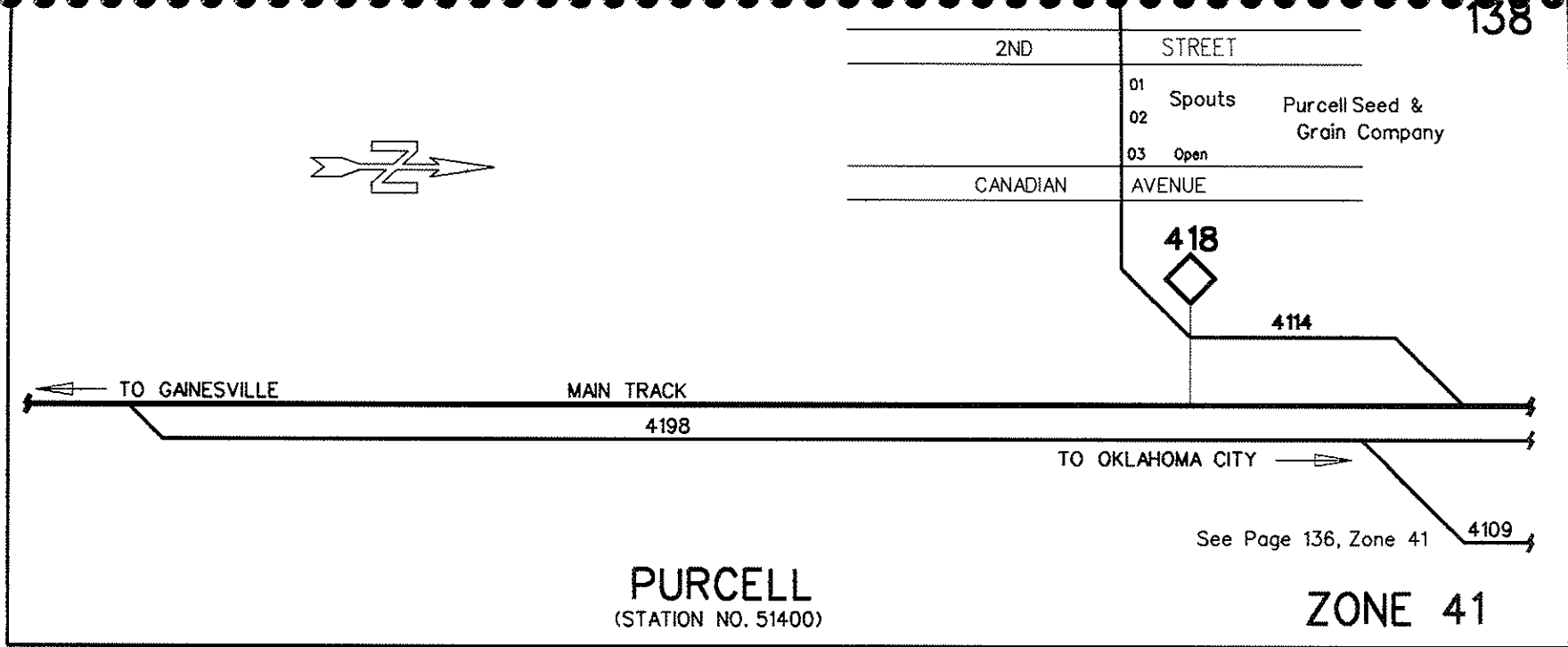

Zone 10 (Midwest City 51590) Midwest City Industrial Spur

10 01 00	Market Pre-Pak		10 05 00	Makins Cement	
10 01 01	Market Pre-Pak	(door)	10 05 01	Makins Cement Co.	(ut pit)
thru 02			10 05 02	Makins Cement Co	(dock)
10 01 03	Market Pre=Pak	(dock)	10 06 00	Vacant	
thru 04			10 06 01	Vacant	(dock)
10 01 05	Market Pre-Pak	(open)	thru 03		
10 04 00	Tinker Lead		10 06 04	Vacant	(open)
			thru 05		
			10 12 00	Tinker ATSF Rec'g Trk	
			10 13 00	Tinker ATSF Del'y Trk	
			10 14 00	Run-A-Round Track	
			10 99 00	OCAA Main Track	

Page 139

140

C.E. NO. 11806-SK Engineering & Technology Development 4/92

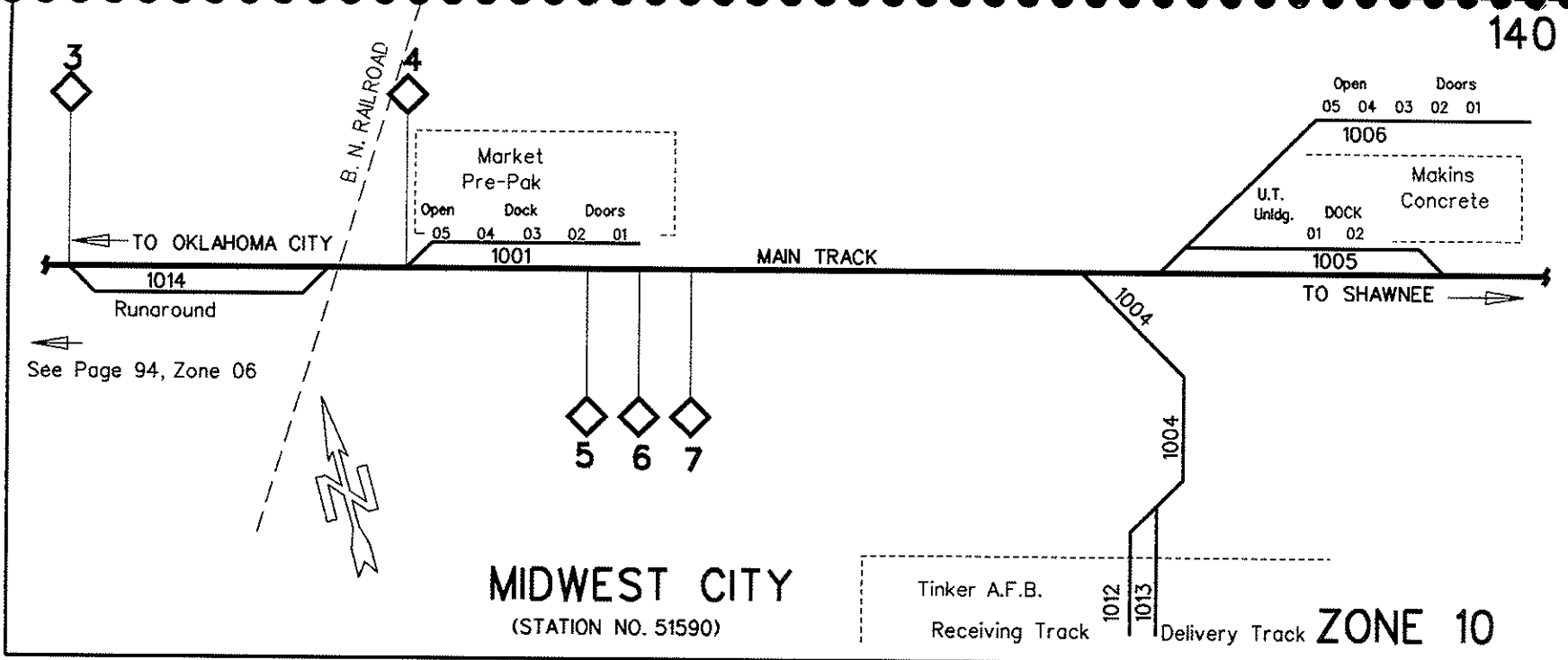

Zone 37 (Shawnee 51600) Shawnee Industrial Spur

37 01 00	Wolverine		37 03 01	Mobil Chemical Co	(hose)
37 01 01	Wolverine	(open)	thru 09		
thru 02			37 04 00	Allen-Bradley Co	
37 01 03	Wolverine	(dock)	37 04 01	Allen-Bradley	(pit)
thru 04			thru 02		
37 01 05	Wolverine	(open)	37 05 00	Allen-Bradley Co	
thru 06			37 05 01	Allen-Bradley	(dock)
37 02 00	Runaround Track		37 99 00	Main Track	
37 03 00	Mobil Chemical				

Page 141

C.E. NO. 11806-SK Engineering & Technology Development 4/92

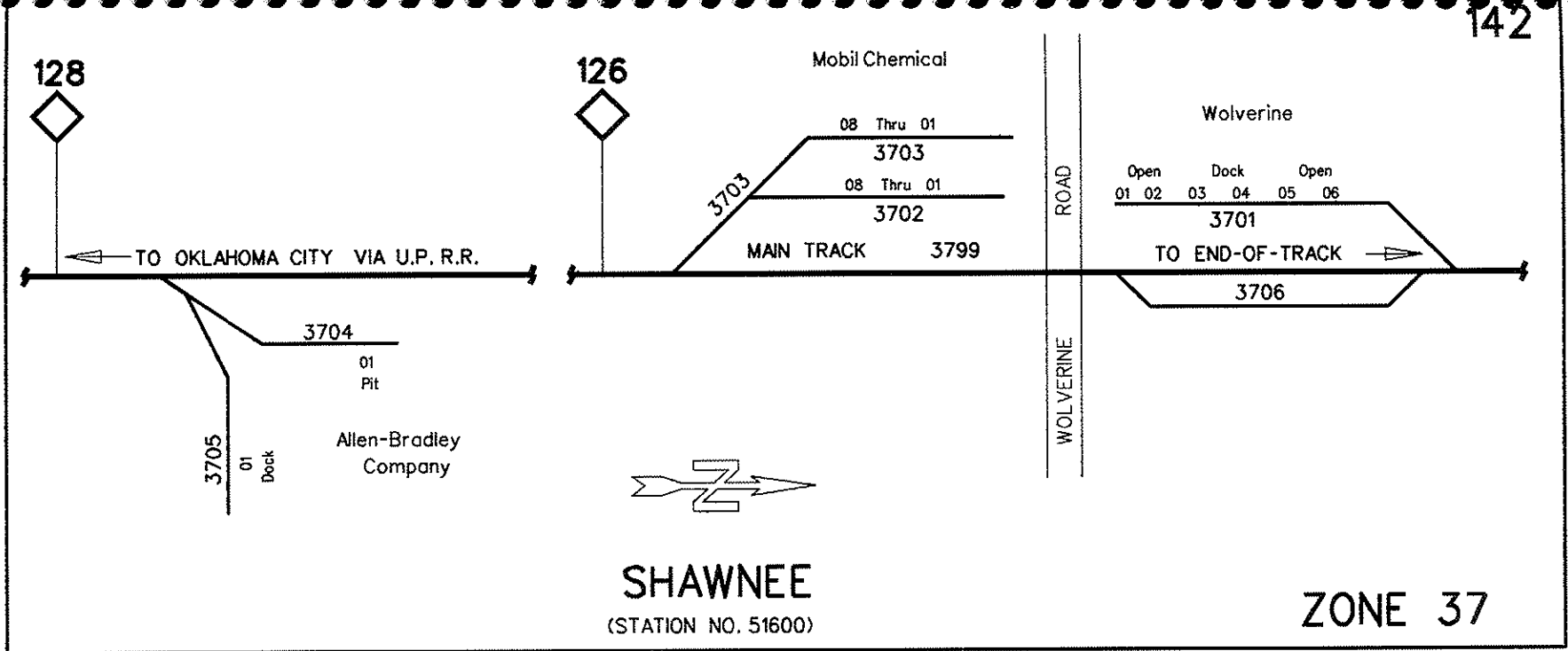

142

142

Zone 37 (Shawnee 51600) Shawnee Industrial Spur

- 37 07 00 White Building Material Center
- 37 07 01 White Building Material (dock)
- thru 06
- 37 08 00 Tie-Up Track
- 37 99 00 Main Track

C.E. NO. 11806-SK Engineering & Technology Development 4/92

144

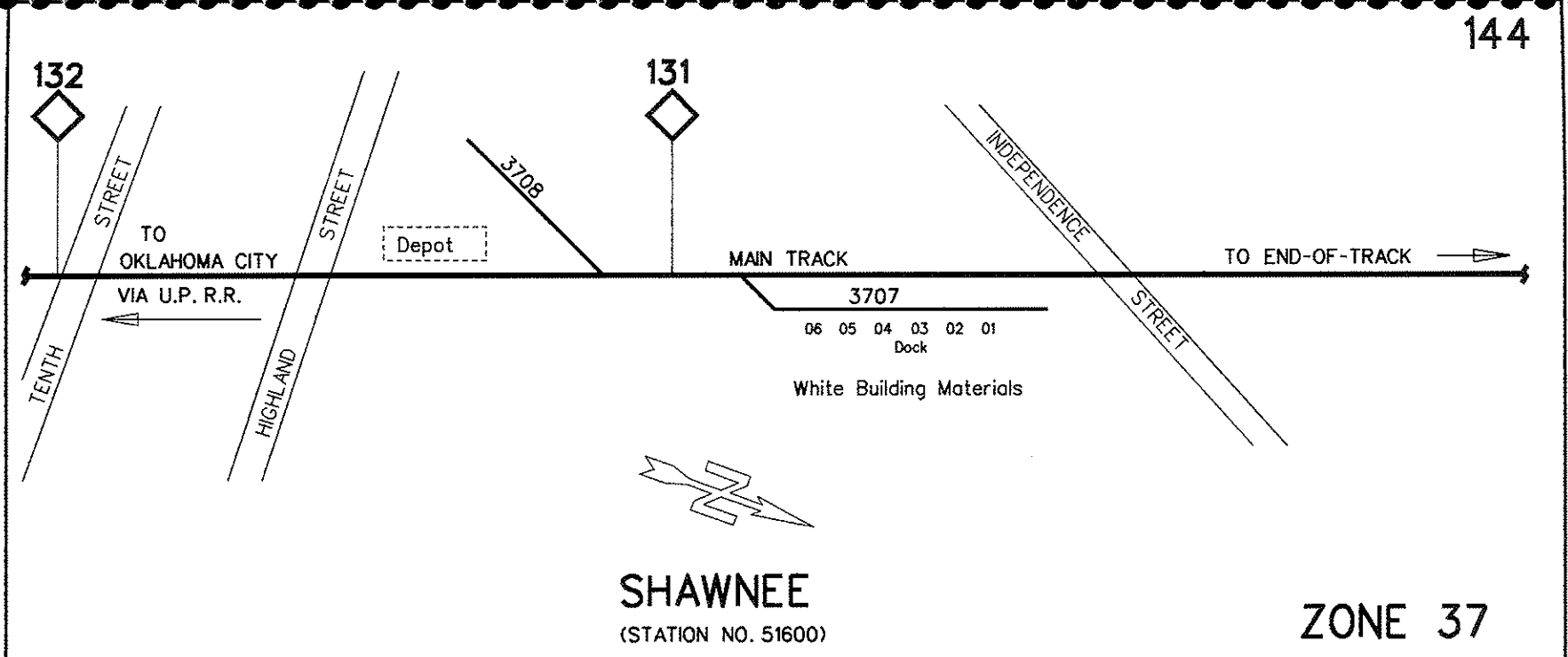

SHAWNEE
(STATION NO. 51600)

ZONE 37

Zone 37 (Shawnee 51600) Shawnee Industrial Spur

37 12 00	Dale Distributing		37 17 00	East Leg of Wye
37 12 01	Dale Distributing	(door)	37 18 00	West Leg of Wye
thru 02			37 95 00	MKT Interchange Dely Trk
37 15 00	South Pass		37 96 00	MKT Interchange Recv Trk
37 16 00	Shawnee Steel-Ball Pipe		37 97 00	Passing Track
37 16 01	Shawnee Steel	(open)	37 98 00	Siding
thru 06			37 99 00	Main Track
37 16 11	Ball Pipe & Supply Co	(open)		
thru 14				

C.E. NO. 11806-SK Engineering & Technology Development 4/92

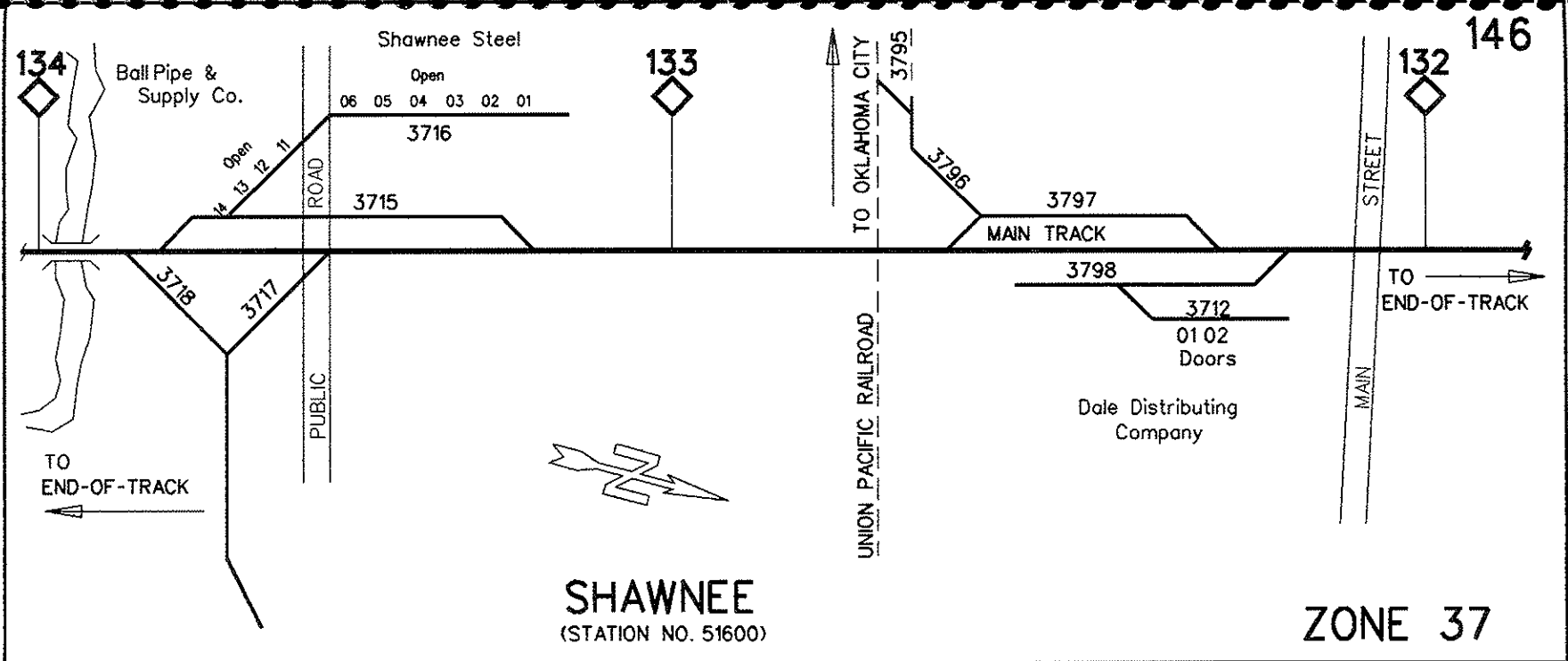

146

Zone 37 (Shawnee 51600) Shawnee Industrial Spur

37 21 00	Shawnee Milling	
37 21 01	Shawnee Milling Co	(open)
thru 05		
37 21 06	Shawnee Milling Co	(dock)
thru 09		
37 21 10	Shawnee Milling Co	(spout)
37 96 00	MKT Interchange Recv	

Page 147

C.E. NO. 11806-SK Engineering & Technology Development 4/92

148

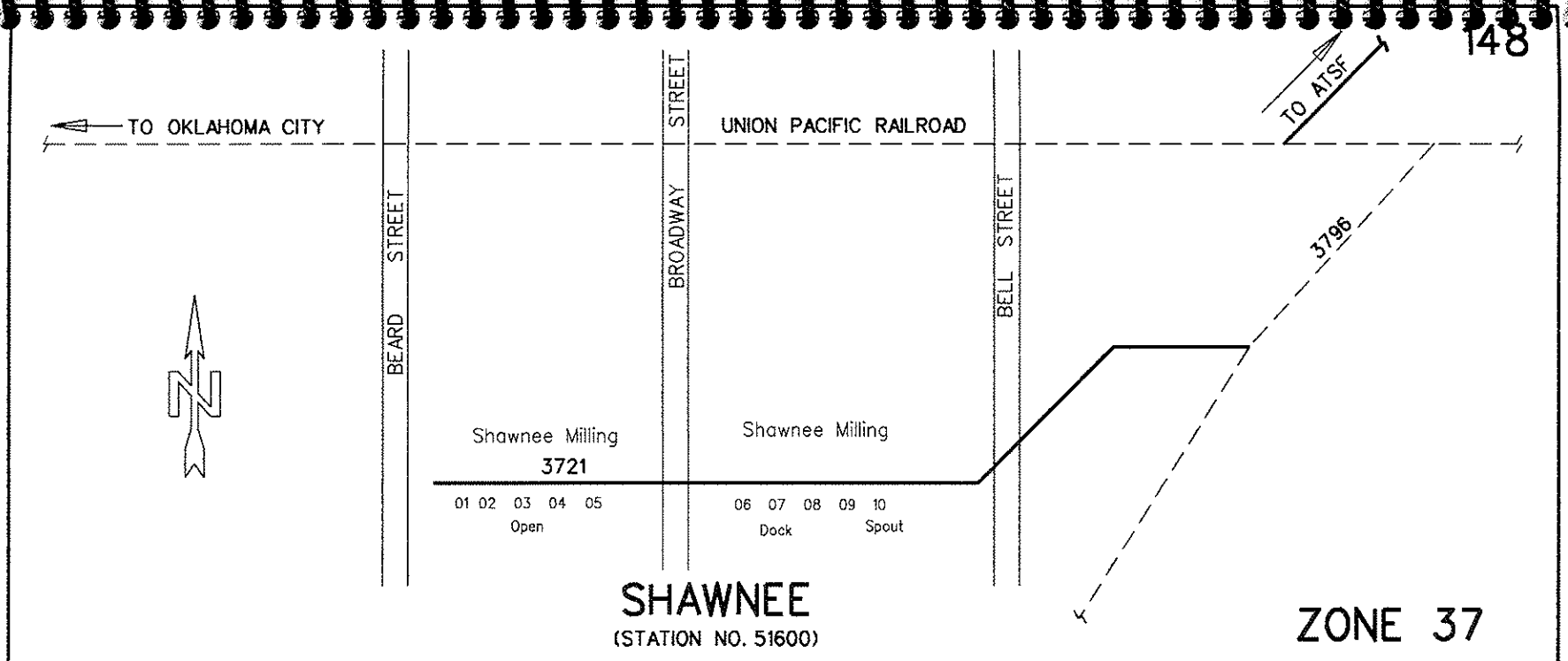

SHAWNEE
(STATION NO. 51600)

ZONE 37

Zone 61 (Wayne 51325 Oklahoma Subdivision)

- 61 01 00 Wayne Siding
- 61 03 00 Wayne House Track
- 61 99 00 Main Track

Page 149

C.E. NO. 11806-SK Engineering & Technology Development 4/92

150

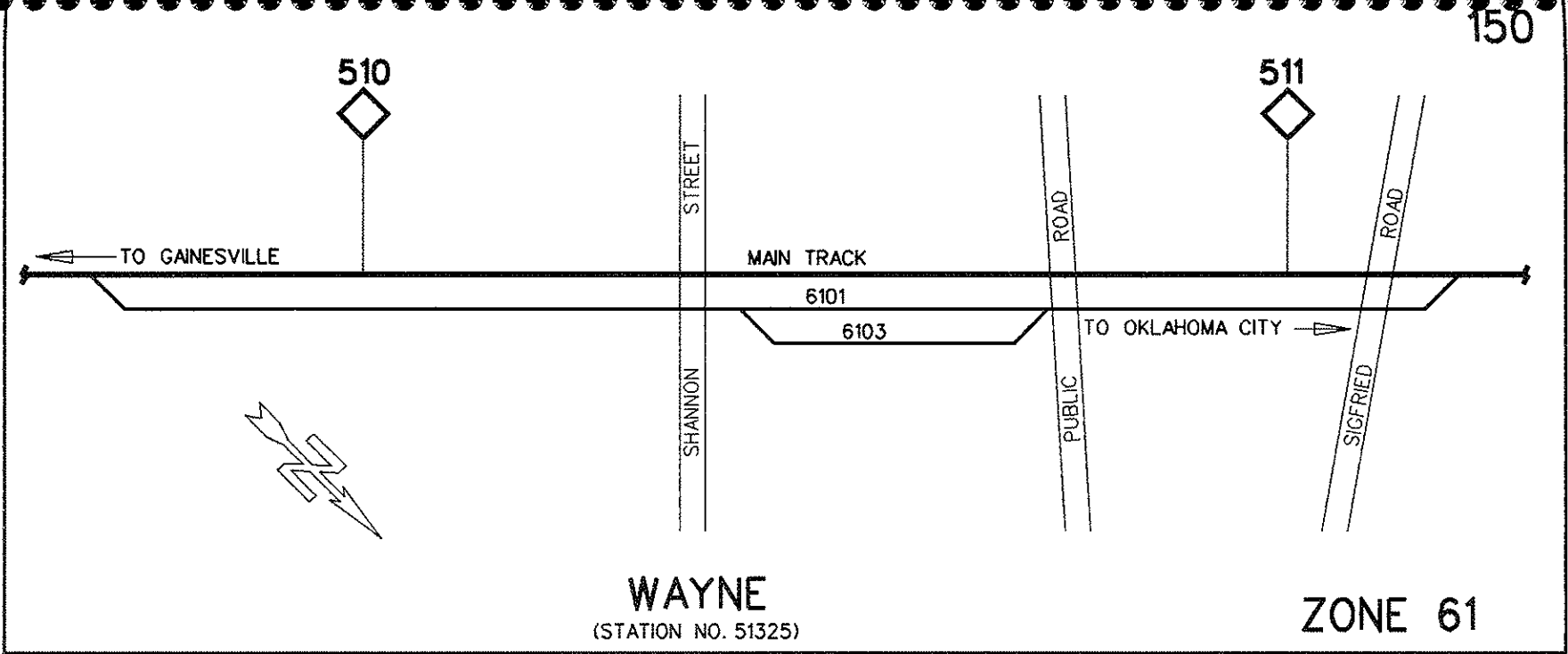

Zone 61 (Paoli 51315) Oklahoma Subdivision

61 04 00 Paoli Siding
61 99 00 Main Track

Page 151

C.E. NO. 11806-SK Engineering & Technology Development 4/92

152

152

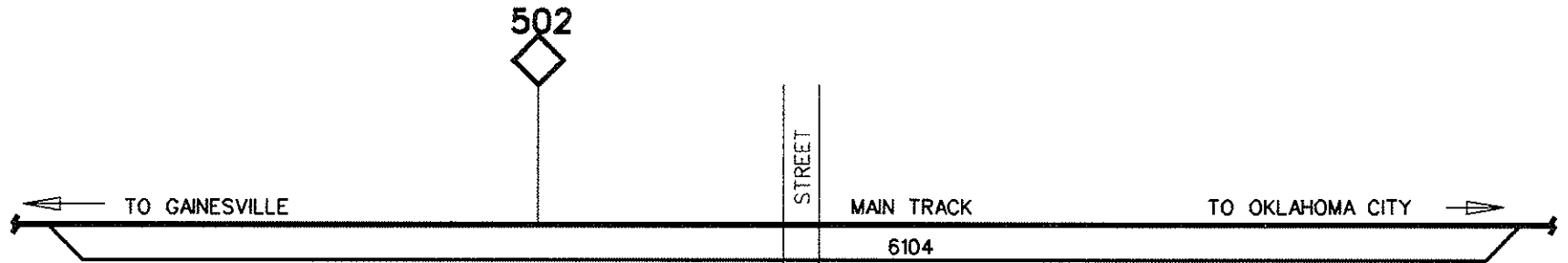

PAOLI
(STATION NO. 51315)

ZONE 61



Zone 60 (Pauls Valley 51300) Old Lindsay District

60 01 00	Martin Fertilizer Track	
60 01 01	Martin Fertilizer Co	(u.t. pit)
60 01 02	Martin Fertilizer Co	(o.h. spout)
60 02 00	Texaco Track	
60 02 01	Texaco Warehouse	(door)
60 03 00	Union Carbide Track	
60 03 01	Union Carbide	(door)
thru 06		(door)
60 99 00	Main Track Old Lindsay District	

Pagee 153

C.E.NO.11806-SK Engineering & Technology Development 4/92

154

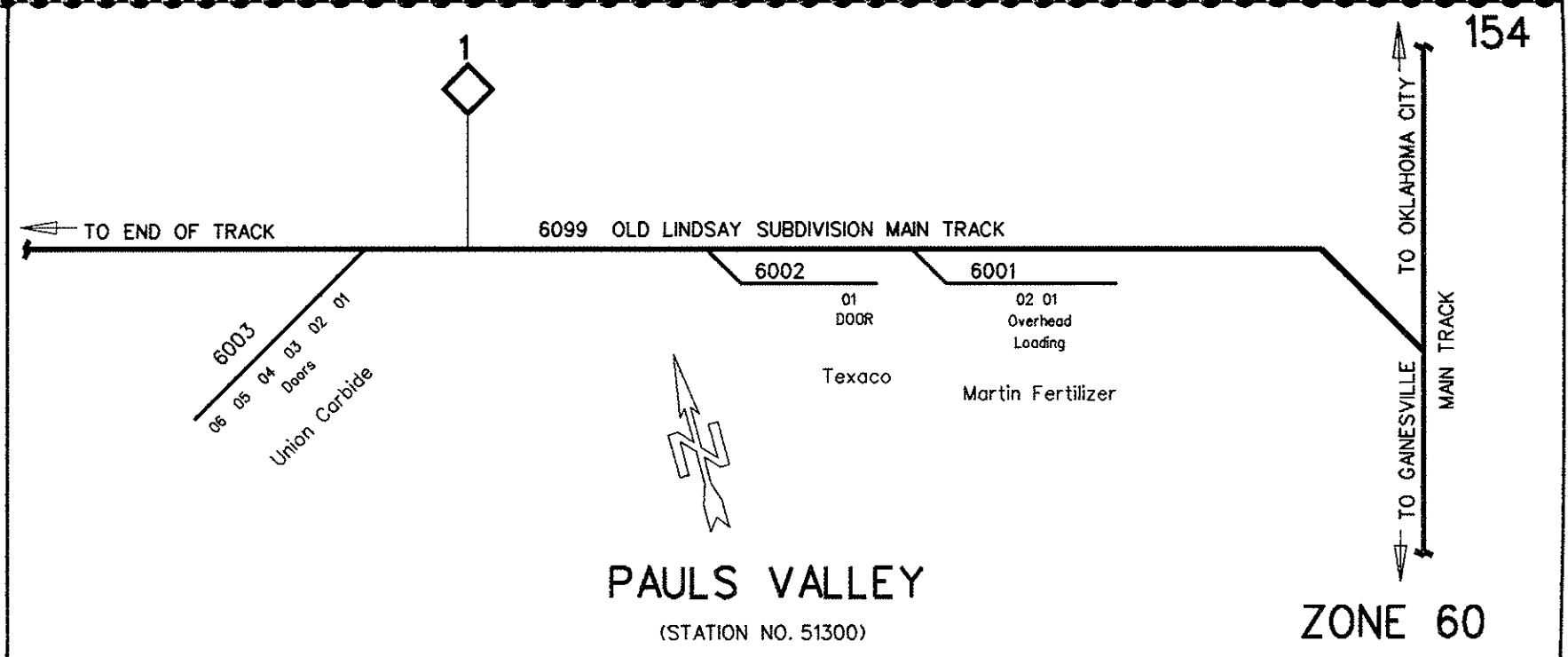

Zone 61 (Pauls Valley 51300) Oklahoma Subdivision

61 10 00	Siding		61 21 00	Compress Track
61 16 00	Mill Track		61 25 00	Pauls Valley Old Gulf Jct 1
61 16 01	Kirksey Wholesale Plywood	(dock)	61 26 00	Pauls Valley Old Gulf Jct 2
61 16 02	Farm-Ranch Grain Co	(o.h. spout)	61 99 00	Main Track
61 17 00	Tail Track			

Page 155

C.E. NO. 11806-SK Engineering & Technology Development 4/92

156

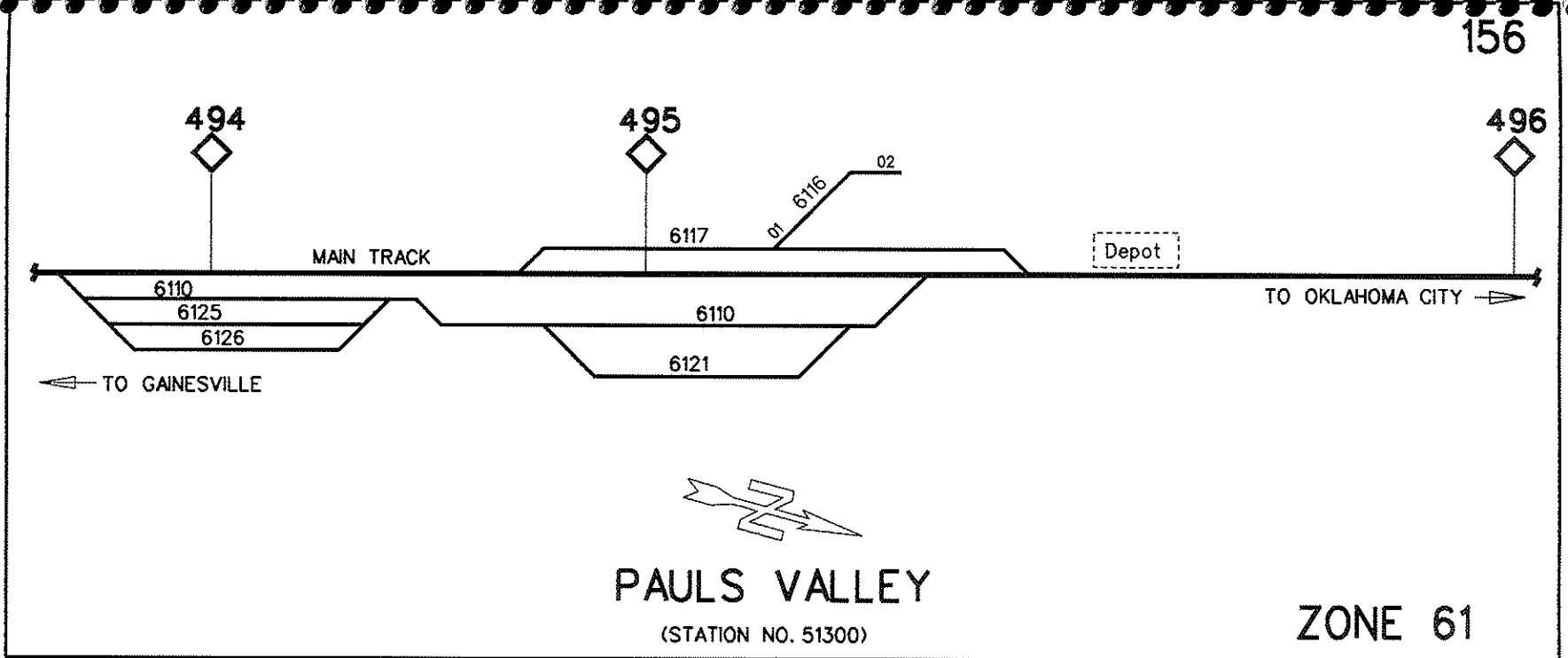

Zone 62 (Wynnewood 51255) Oklahoma Subdivision

62 01 00	House Track		62 06 00	Kerr-McGee Asphalt No. 1	
62 01 01	Martin Feed	(door)	62 06 01	Kerr-McGee	(asphalt)
thru 02			thru 12		
62 02 00	Siding Track		62 07 00	Kerr-McGee Asphalt No. 2	
62 03 00	East Pass Track		62 07 01	Kerr-McGee	(asphalt)
62 04 00	Mill Track		thru 12		
62 05 00	Seed Spur		62 08 00	Kerr-McGee Coke Spur	
62 05 01	Kerr-McGee	(rack)	62 08 01	Kerr-McGee	(dock)
thru 05			thru 02		
			62 99 00	Main Track	

C.E. NO. 11806-SK Engineering & Technology Development 4/92

158

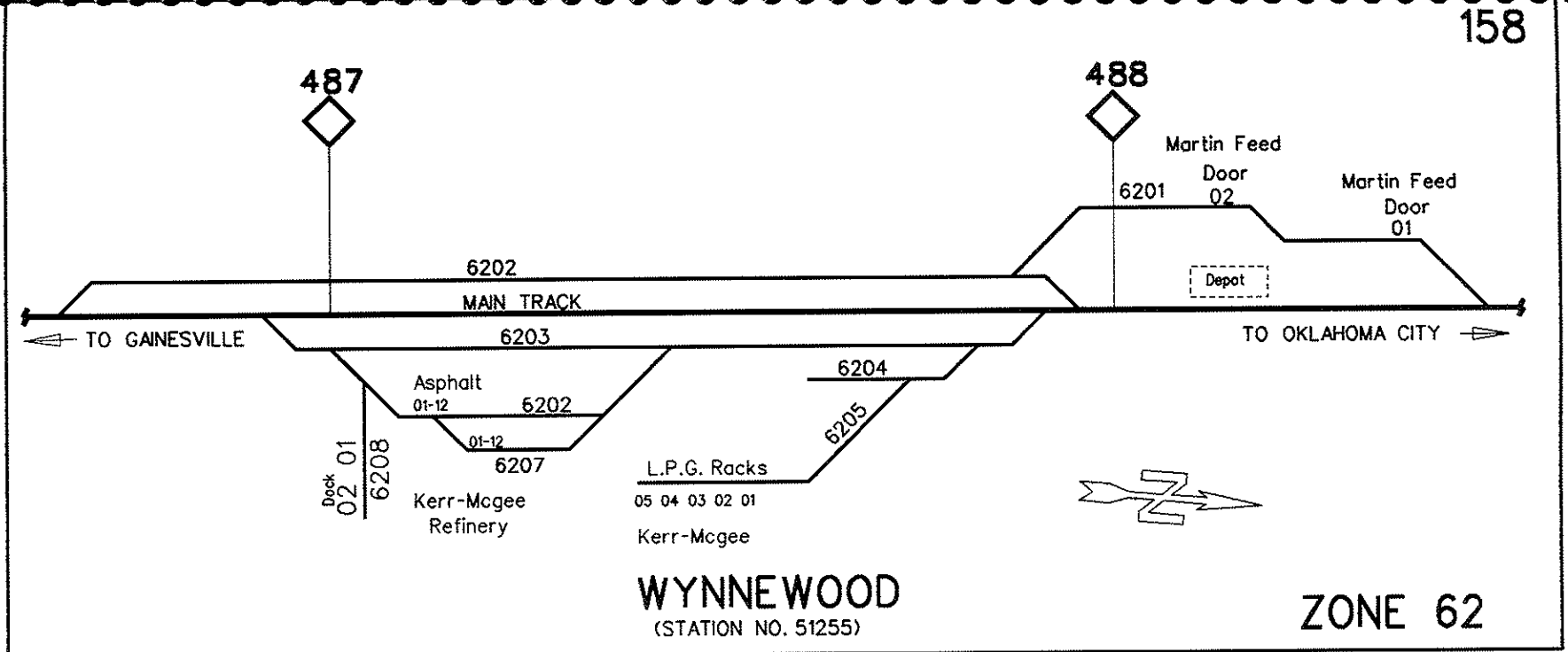

Zone 62 (Davis 51250) Oklahoma Subdivision

62 11 00	Siding		62 50 00	West Leg Wye & Western Rock
62 13 00	Track No. 1		62 51 00	No. 1 Track & Western Rock Pro
62 14 00	Track No. 2		62 52 00	No. 2 Track & Western Rock Pro
62 14 01	Stillwater Milling	(u.t.pit)	62 53 00	No. 3 Track & Western Rock Pro
61 14 02	Stillwater Milling	(door 01)	62 54 00	No. 4 Track & Western Rock Pro
62 14 03	Stillwater Milling	(door 02)	62 55 00	No. 5 Track & Western Rock Pro
62 14 04	Stillwater Milling	(door 03)	62 56 00	East Leg Wye & Western Rock Pro
62 15 00	Storage Track		62 99 00	Main Track
62 15 01	TOFC Ramp	(dock)		
62 16 00	Halliburton Spur			
62 16 01	Halliburton Co	(door)		
thru 02				

C.E.NO.11806-SK Engineering & Technology Development 4/92

160

160

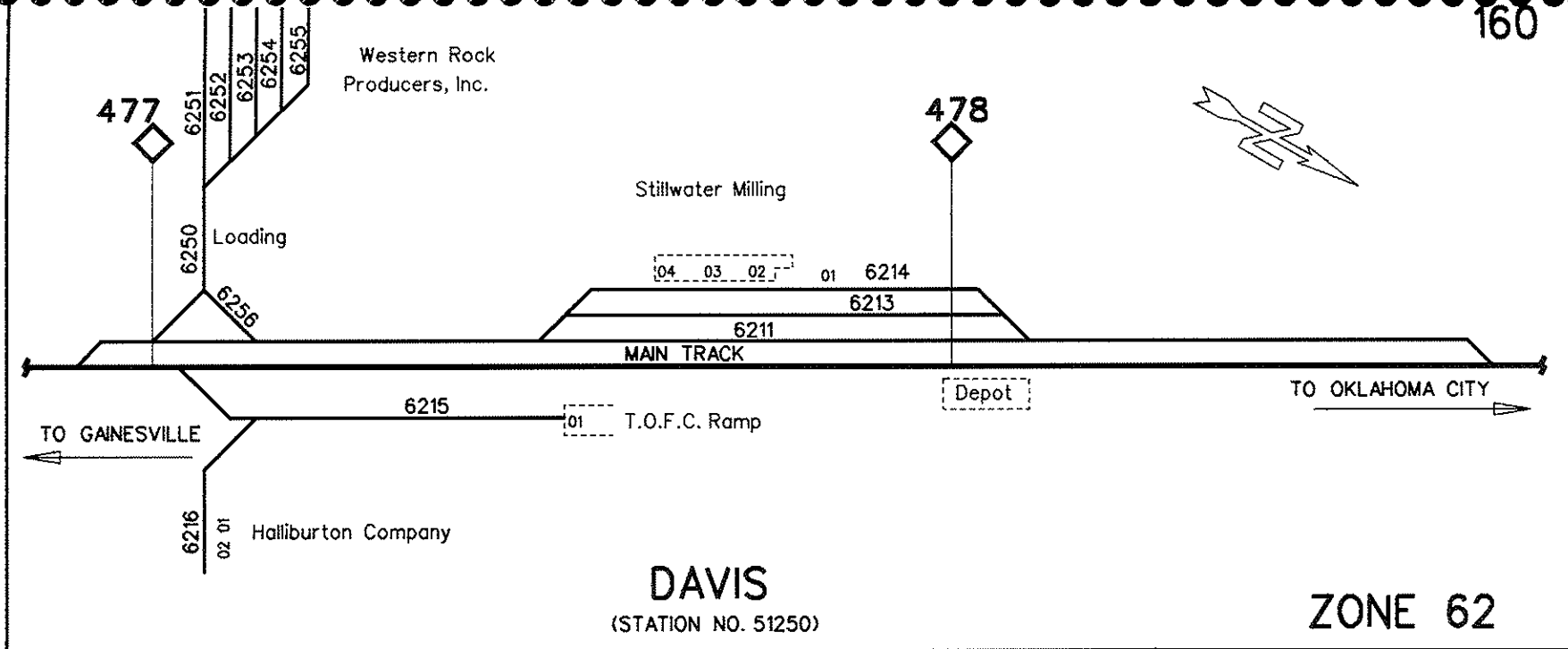

Zone 62 (Rayford (51245) Oklahoma Subdivision

62 20 00 West Storage Track
62 99 00 Main Track

162

C.E. NO. 11807-SK Engineering & Technology Development 4/92

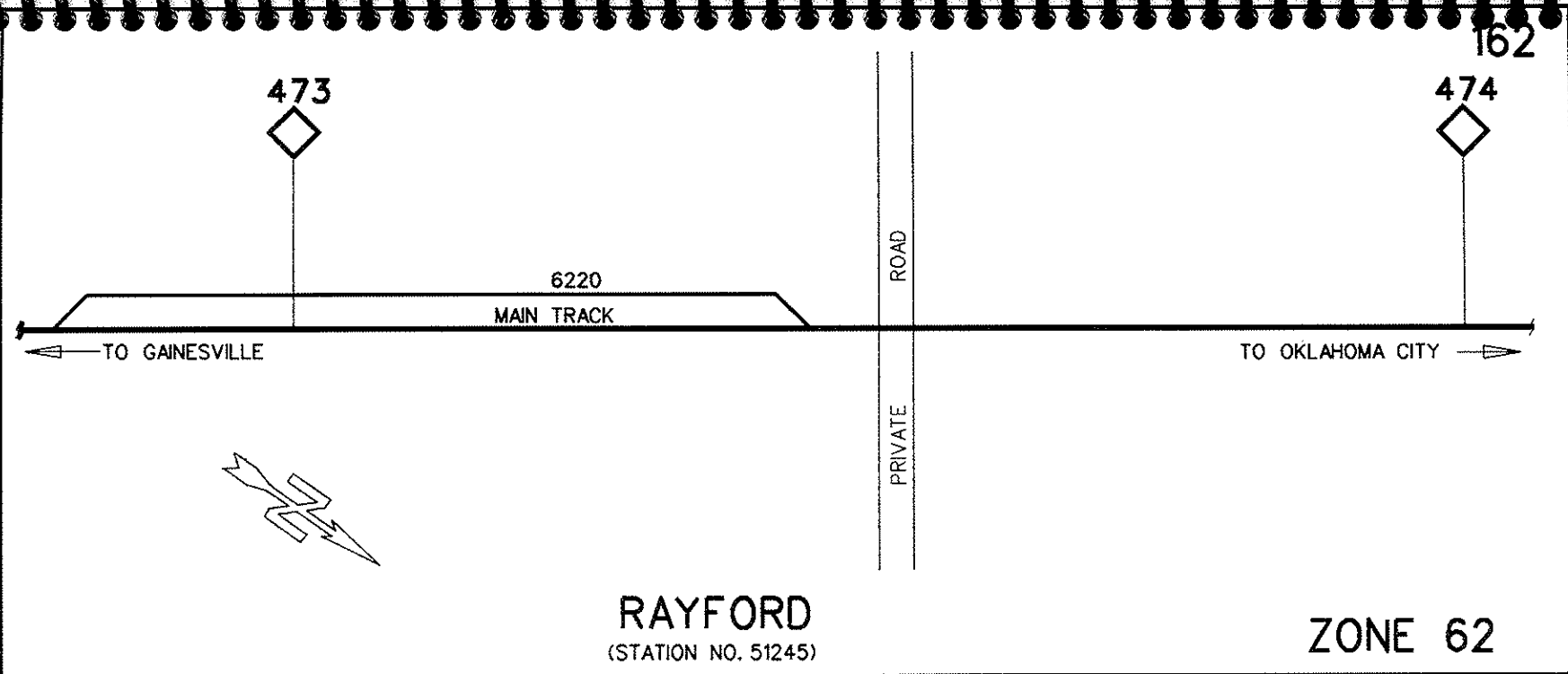

RAYFORD
(STATION NO. 51245)

ZONE 62

Zone 62 (Dougherty 51240) Oklahoma Subdivision

- 62 25 00 Dougherty Siding (8599 ft)
- 62 30 00 Dougherty GC Track 3
- 62 99 00 Main Track

164

C.E. NO. 11807-SK Engineering & Technology Development 4/92

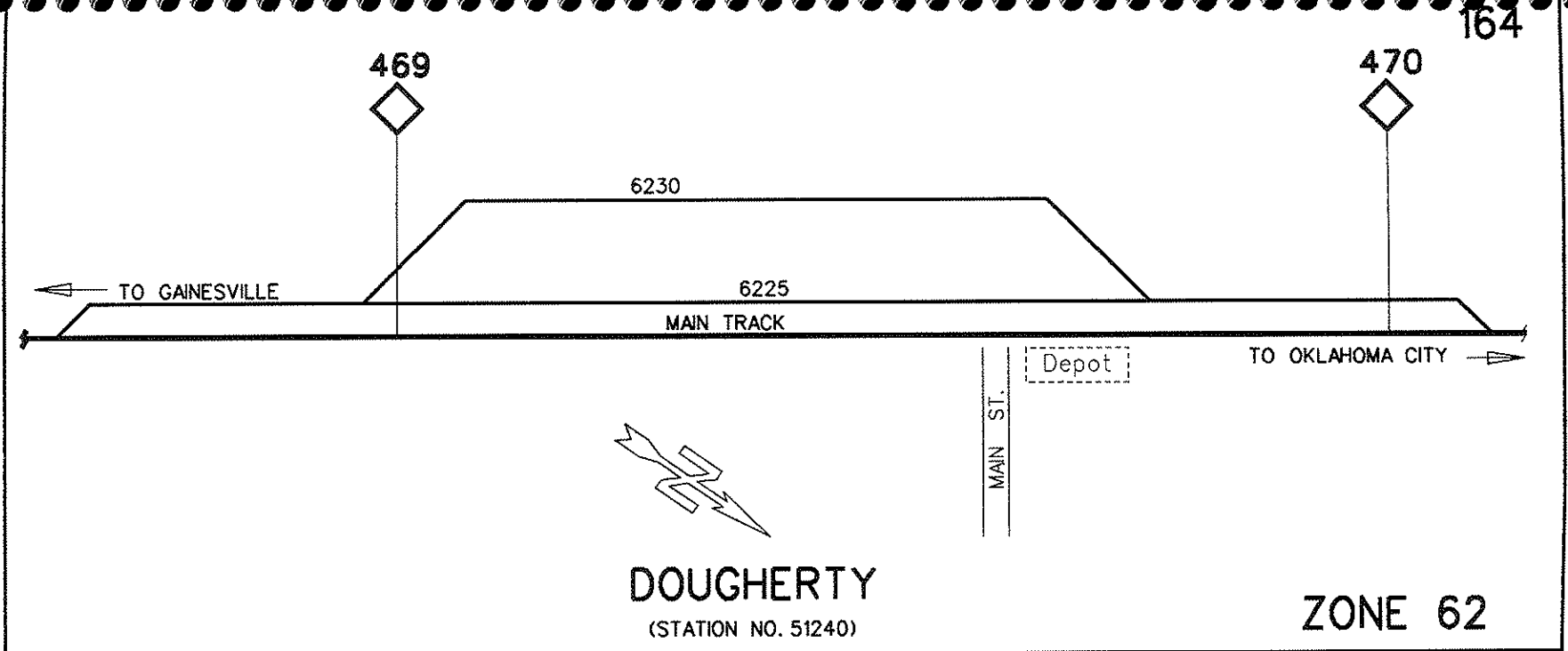

164

DOUGHERTY
(STATION NO. 51240)

ZONE 62

Zone 62 (Crusher 51230) Oklahoma Subdivision

62 40 00 Crusher Track No. 1
62 99 00 Main Track

Page 165

C.E.NO.11807-SK Engineering & Technology Development 4/92

166

166

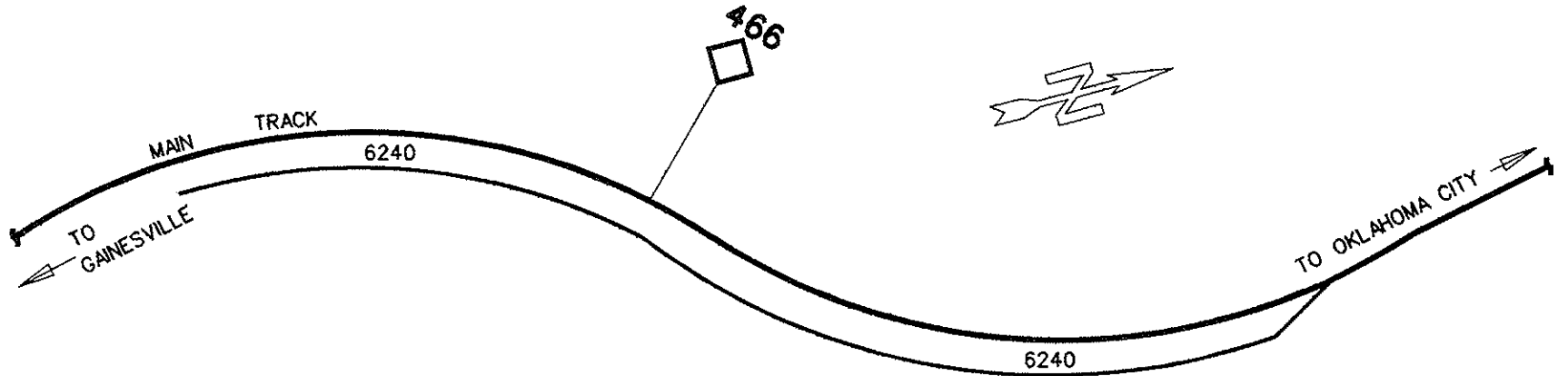

CRUSHER
(STATION NO. 51230)

ZONE 62

Zone 63 (Gene Autry 51225) Oklahoma Subdivision

63 01 00	Gene Autry Siding	
63 02 00	House Track (Merrico Grain)	
63 02 01	Merrico Grain	(spout)
63 99 00	Main Track	

Page 167

168

S.C.E. NO. 11807-SK Engineering & Technology Development 4/92

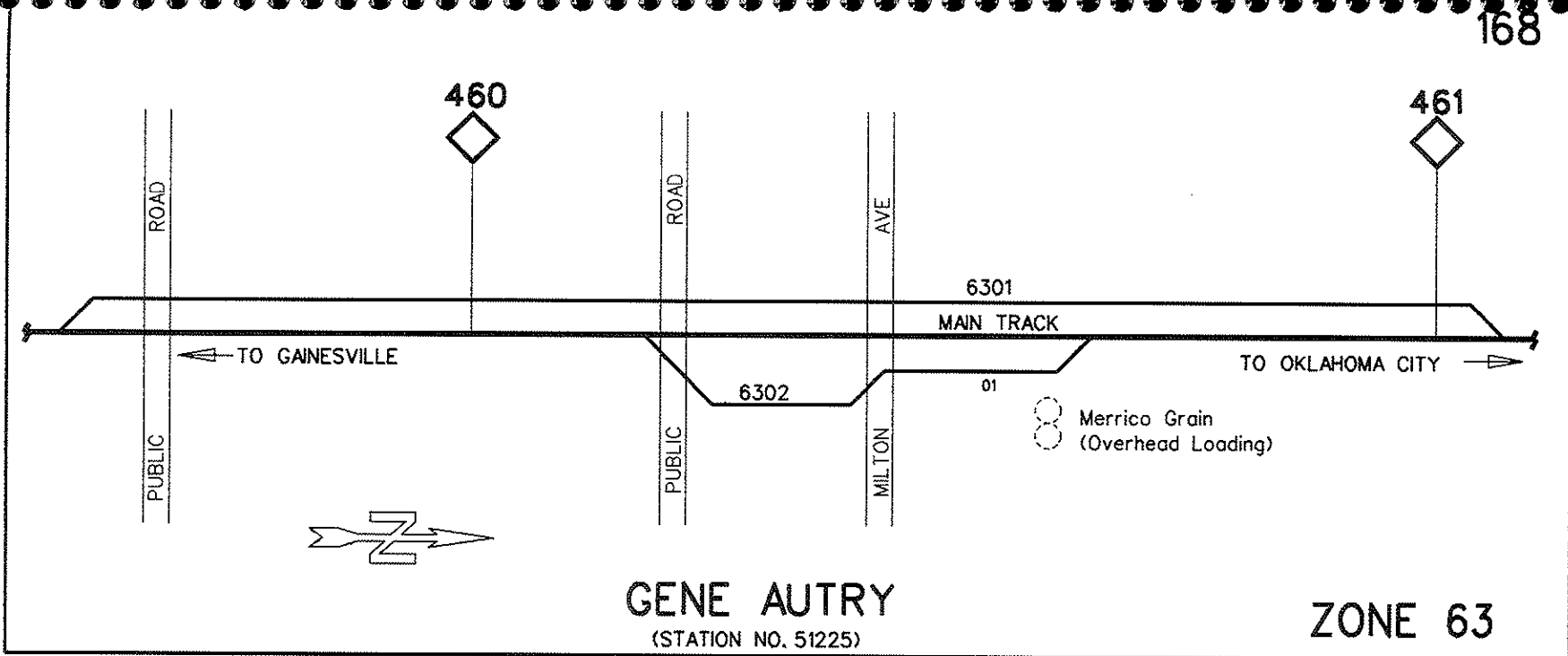

168

GENE AUTRY
(STATION NO. 51225)

ZONE 63

Zone 63 (Ardmore 51200) Oklahoma Subdivision

63 11 00	Ardmore Team Track		63 15 01	Total Petroleum	(o.h.rack)
63 12 00	Georgia Pacific Track		thru 10		
63 12 01	Georgia Pacific	(dock)	63 16 00	Total Petroleum West Rack Track	
thru 06			63 16 01	Total Petroleum	(o.h. rack)
63 12 10	Georgia Pacific	(dock)	thru 10		
thru 16			63 20 00	G E O Drilling Track	
63 13 00	Ardmore Spur (Off Team Track)		63 21 00	Coline Track No. 1	
63 14 00	Total Petroleum Asphalt O.H. Rack		63 22 00	Coline Track No. 2	
63 14 01	Total Petroleum	(asphalt o.h. rack)	63 99 00	Main Track	
thru 11					
63 15 00	Total Petroleum East Rack Track				

170

C.E.NO.11807-SK Engineering & Technology Development 4/92

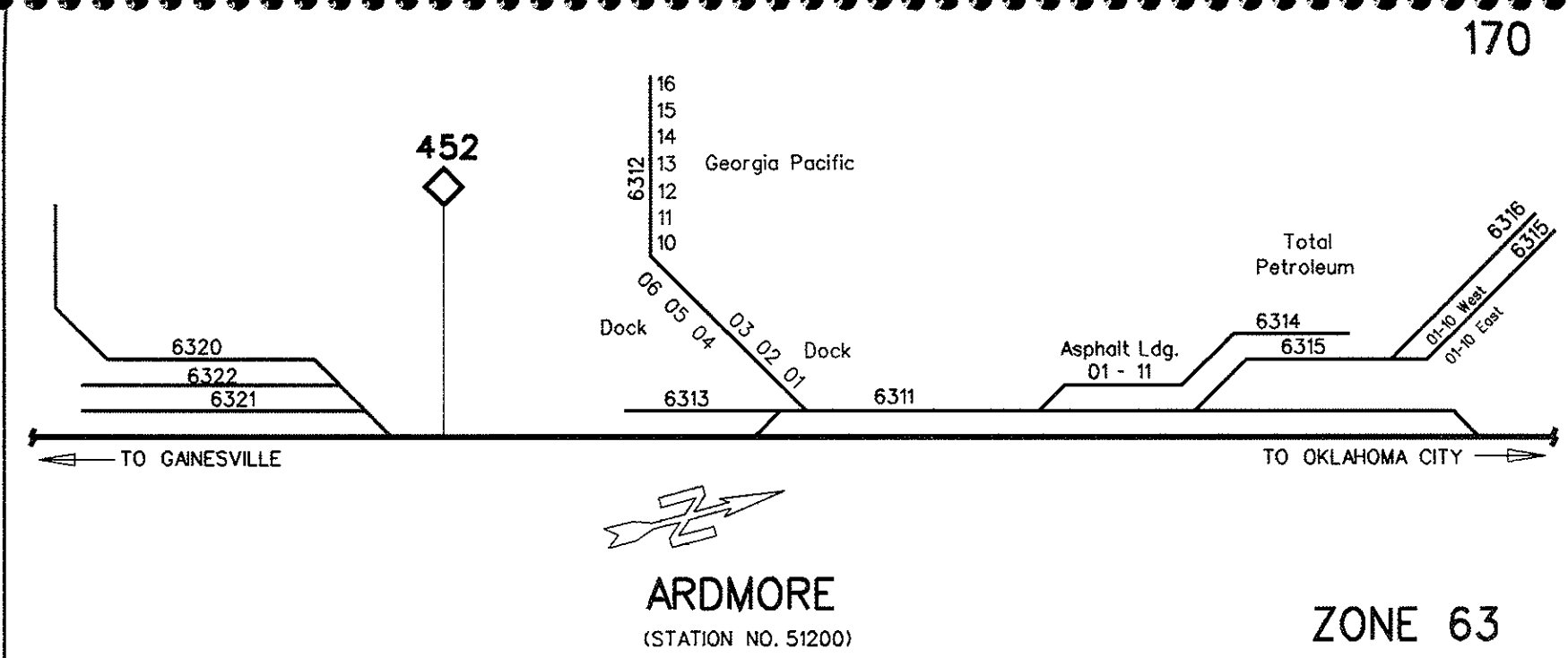

Zone 63 (Ardmore 51200) Oklahoma Subdivision

63 76 00	Switching Lead (Old BN No.1)		63 81 06	Magcobar	(ramp)
63 81 00	MP 627 Industry Lead-Drill Mud		63 81 07	Hughes Drilling Supply(u.t.device)	(pit)
63 81 01	Drilling Mud Co	(door)	63 18 08	Hughes Drilling Supply	(ramp)
63 81 02	Stanley Dx Warehouse	(door)	thru 10		
63 81 03	Agri Products	(ramp)	63 82 00	Oklahoma Iron Track	
63 81 04	Agri Products (u.t.device)	(pit)	63 82 01	Oklahoma Iron Co	(open)
63 81 05	Magcobar (u.t.device)	(pit)	thru 03		

Page 171

172

C.E.NO.11807-SK Engineering & Technology Development 4/92

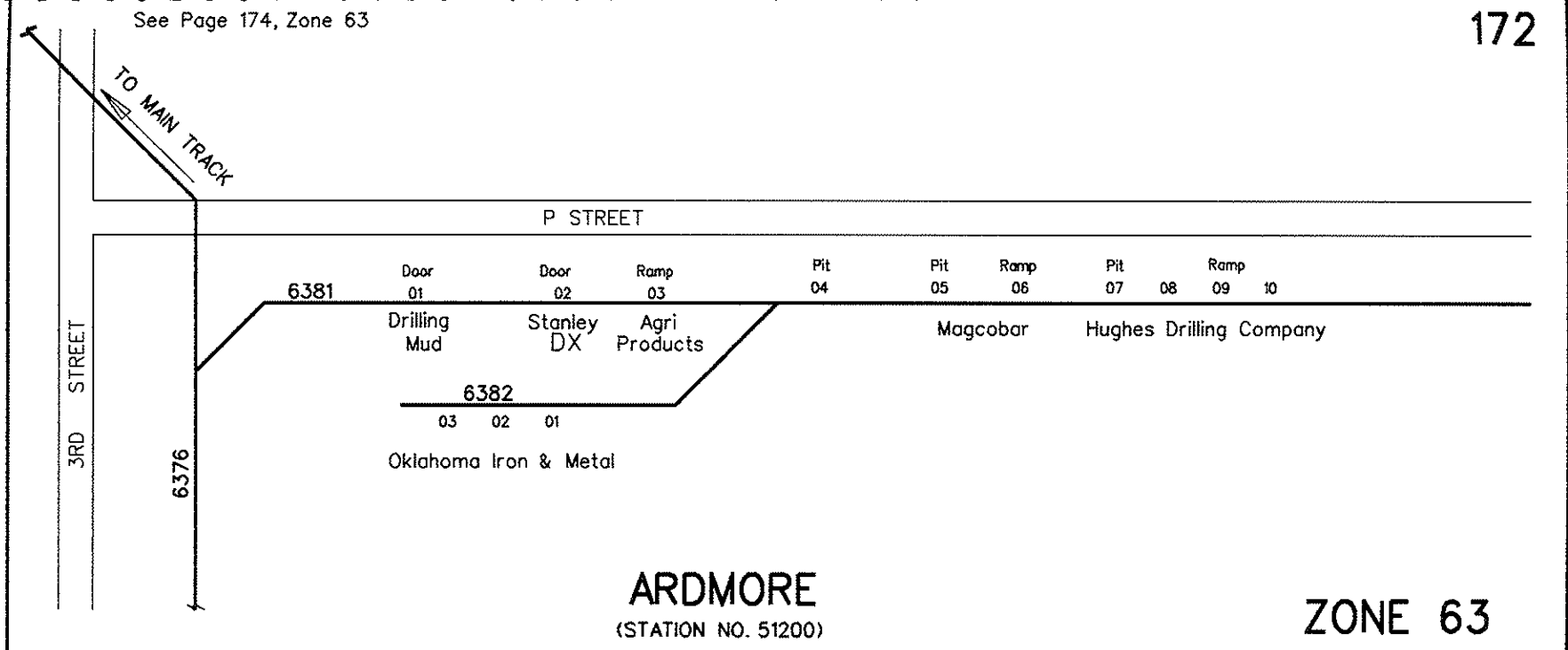

Zone 63 (Ardmore 51200) Oklahoma Subdivision

63 26 00	BN Lead Track	
63 75 00	Lumbermans Millwork Track	
63 75 01	Lumbermans Millwork	(door)
thru 07		
63 76 00	Switching Lead (Old BN No. 1)	
63 76 01	Imco Drilling & Fed Ore & Chem	(door)
63 76 02	Imco Drilling	(auger)
63 98 00	Passenger Main	

Page 173

C.E. NO. 11807-SK Engineering & Technology Development 4/92

174

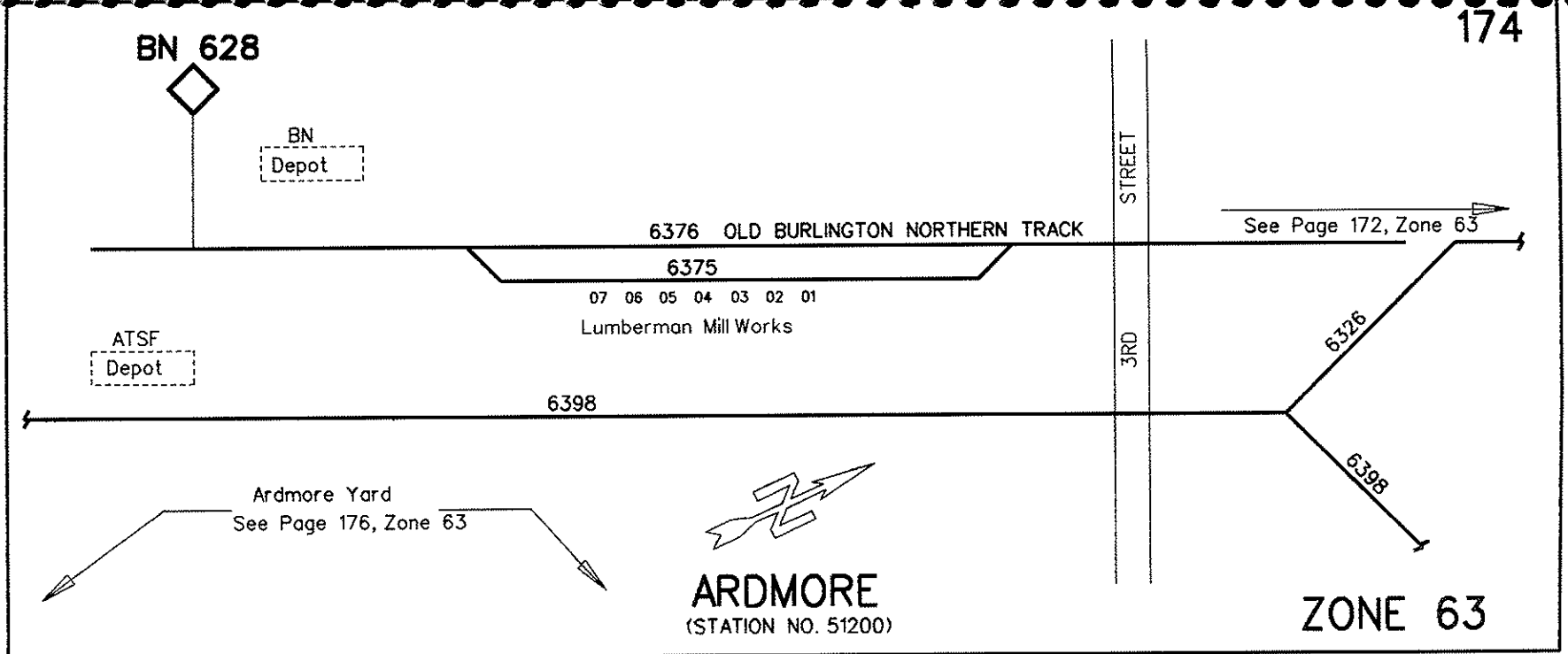

Zone 63 (Ardmore 51200) Oklahoma Subdivision

63 26 00	BN Lead Track	63 46 00	Freight House No. 1
63 27 00	East Ramp	63 47 00	Freight House No. 2
63 28 00	West Ramp	63 48 00	West Dock
63 31 00	Yard Track No. 1	63 49 00	Tyler Simpson
63 32 00	Yard Track No. 2	63 49 01	Comet Mills Store (door)
63 33 00	Yard Track No. 3	63 98 00	Passenger Main
63 34 00	Yard Track No. 4	63 99 00	Main Track
63 35 00	Yard Track No. 5		
63 36 00	Yard Track No. 6		
63 37 00	Yard Track No. 7		
63 38 00	Old House Track		
63 40 00	Short Pass Track		
63 42 00	TOFC Ramp Track		
63 42 01	Ardmore Dock (dock)		

Page 175

C.E. NO. 11807-SK Engineering & Technology Development 4/92

176

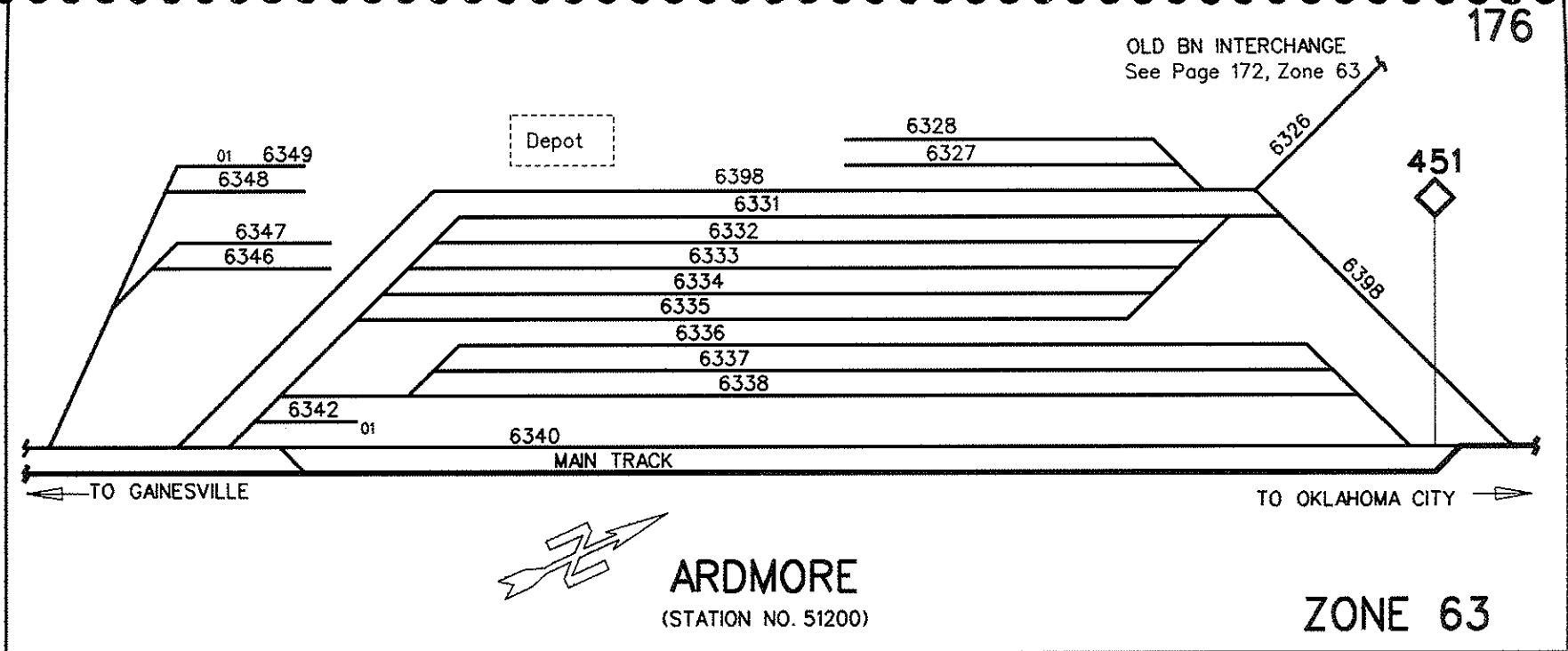

176

ZONE 63

ARDMORE
(STATION NO. 51200)

Zone 63 (Ardmore 51200) Oklahoma Subdivision

65 53 00	Blue Bonnet Mills Track No. 1		63 63 00	Milpark Track	
65 53 01	Blue Bonnet Milling	(u.t.pit)	63 63 01	Milpark Whse	(door)
thru 02			63 63 02	Milpark Whse	(pad)
63 54 00	Blue Bonnet Mills Track No. 2		63 63 03	Vacant Whse	(door)
63 54 01	Blue Bonnet Milling	(door)	63 64 00	Campbell Oil Co	
63 54 02	Blue Bonnet Milling	(u.t.pit)	63 64 01	Campbell	(dock)
63 56 00	Ice House Trk (H and H Co)		thru 02		
63 56 01	H and H Co	(door)	63 98 00	Passenger Main	
63 60 00	North Leg Wye (Uniroyal Lead)		63 99 00	Main Track	
63 61 00	South Leg Wye				
63 62 00	G Street Team Track				

C.E. NO. 11807-SK Engineering & Technology Development 4/92

178

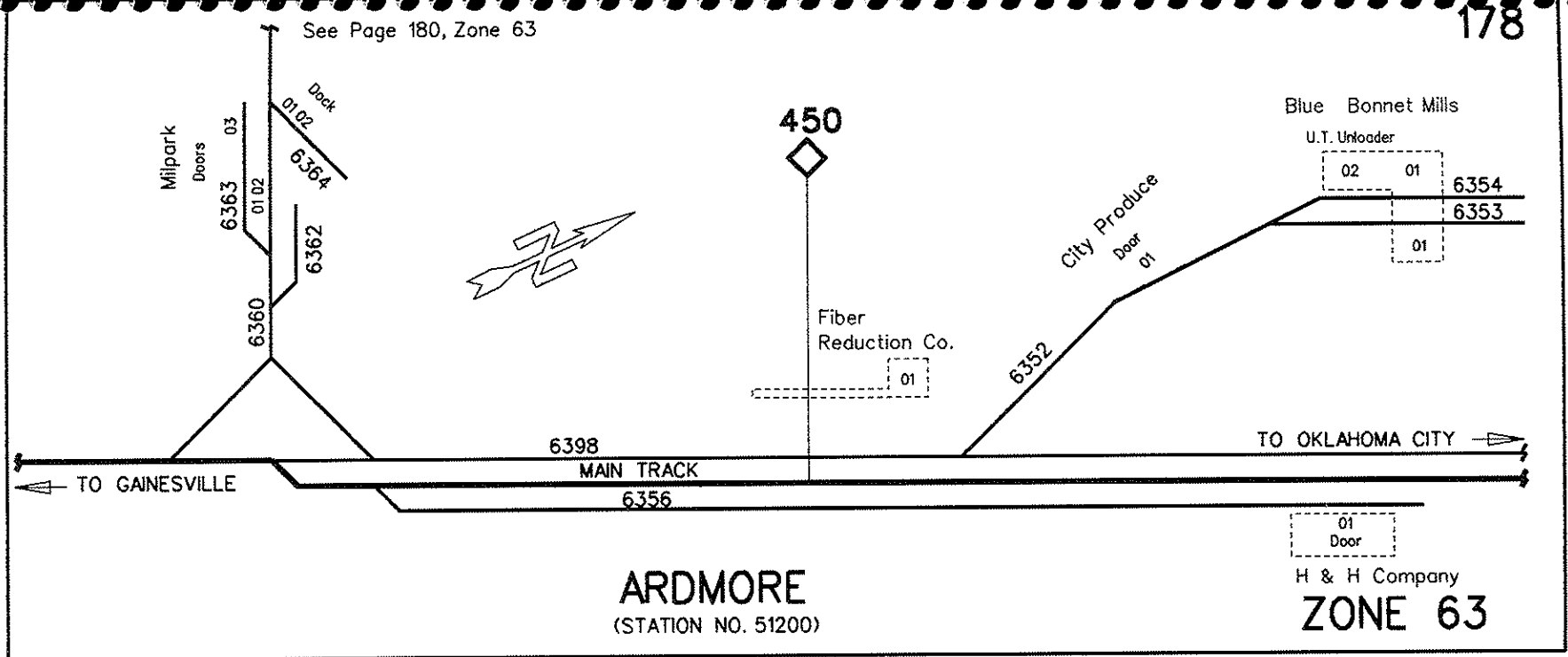

Zone 63 (Ardmore 51200) Uni-Royal

63 60 00	North Leg Wye (Uniroyal Lead)		63 67 25	Uni-Royal Spot 25-2	(door)
63 65 00	O G & E Track/Pole Yard		63 67 26	Uni-Royal Spot 26-2	(door)
63 65 01	O G & E Pole Yard	(open)	63 67 27	Uni-Royal Spot 27-2	(door)
thru 04			63 67 28	Uni-Royal Spot 28-2	(door)
63 66 00	Uni-Royal Track No. 1		63 67 29	Uni-Royal Spot 29-2	(door)
63 66 23	Uni-Royal Spot 23-1	(door)	63 67 30	Uni-Royal Spot 30-2	(door)
63 66 24	Uni-Royal Spot 24-1	(door)	63 68 00	Uni-Royal Storage-Cleaning Track	
63 66 25	Uni-Royal Spot 25-1	(door)	63 69 00	Uni-Royal Lead Track	
63 66 26	Uni-Royal Spot 26-1	(door)	63 70 00	Uni-Royal Whse Track	
63 66 27	Uni-Royal Spot 27-1	(door)	63 70 01	Uni-Royal	(pad)
63 66 28	Uni-Royal Spot 28-1	(door)	thru 03		
63 66 29	Uni-Royal Spot 29-1	(door)	63 70 04	Uni-Royal Whse	(door)
63 66 30	Uni-Royal Spot 30-1	(door)	thru 10		
63 67 00	Uni-Royal Track No. 2		63 71 00	Uni-Royal Tank Track	
63 67 23	Uni-Royal Spot 23-2	(door)	63 71 06	Uni-Royal Tank Unloading	(hose)
63 67 24	Uni-Royal Spot 24-2	(door)	thru 10		

Page 179

C.E.NO.11807-SK Engineering & Technology Development 4/92

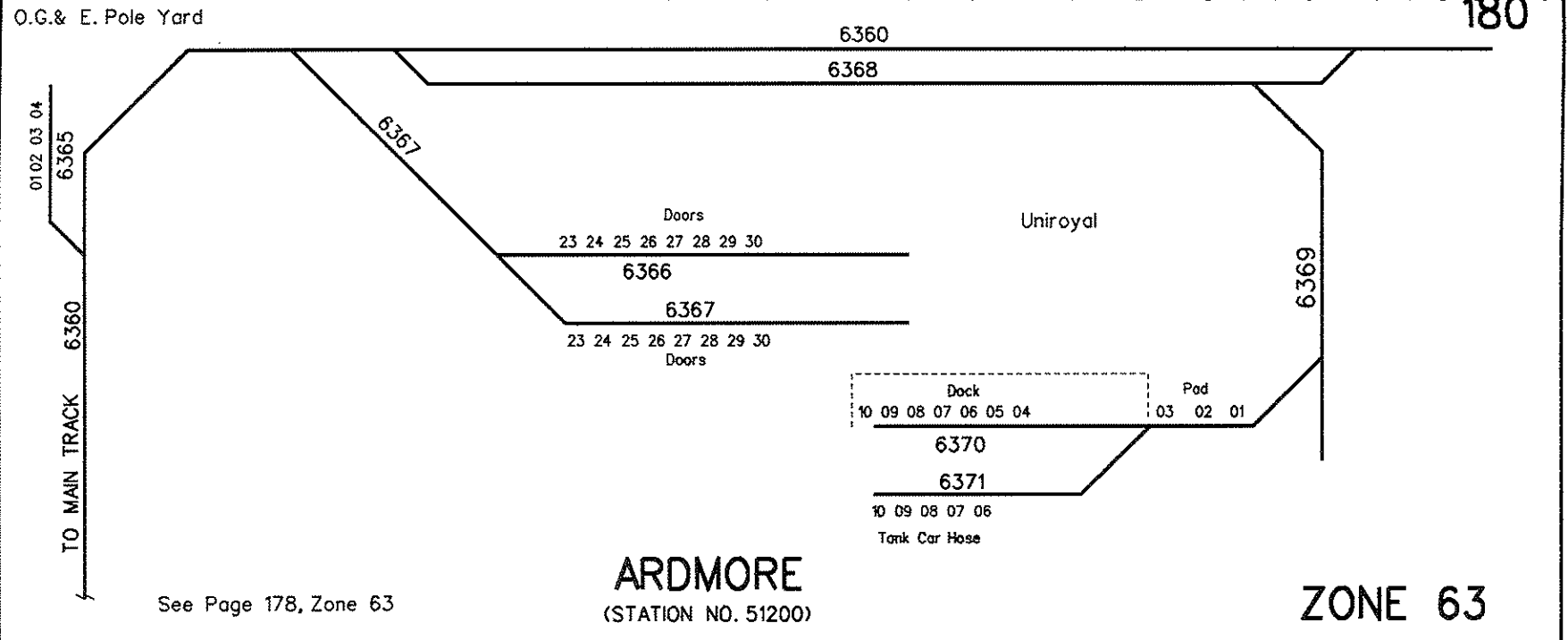

Zone 63 (Ardmore 51200) Oklahoma Subdivision

63 95 00	Western Co Track 1	
63 96 00	Western Co Track 2	
63 96 01	Western Co (Stge Bin)	(u.t.pit)
63 96 02	Western Co	(open)
63 99 00	Main Track	

Page 181

182

C.E. NO. 11807-SK Engineering & Technology Development 4/92

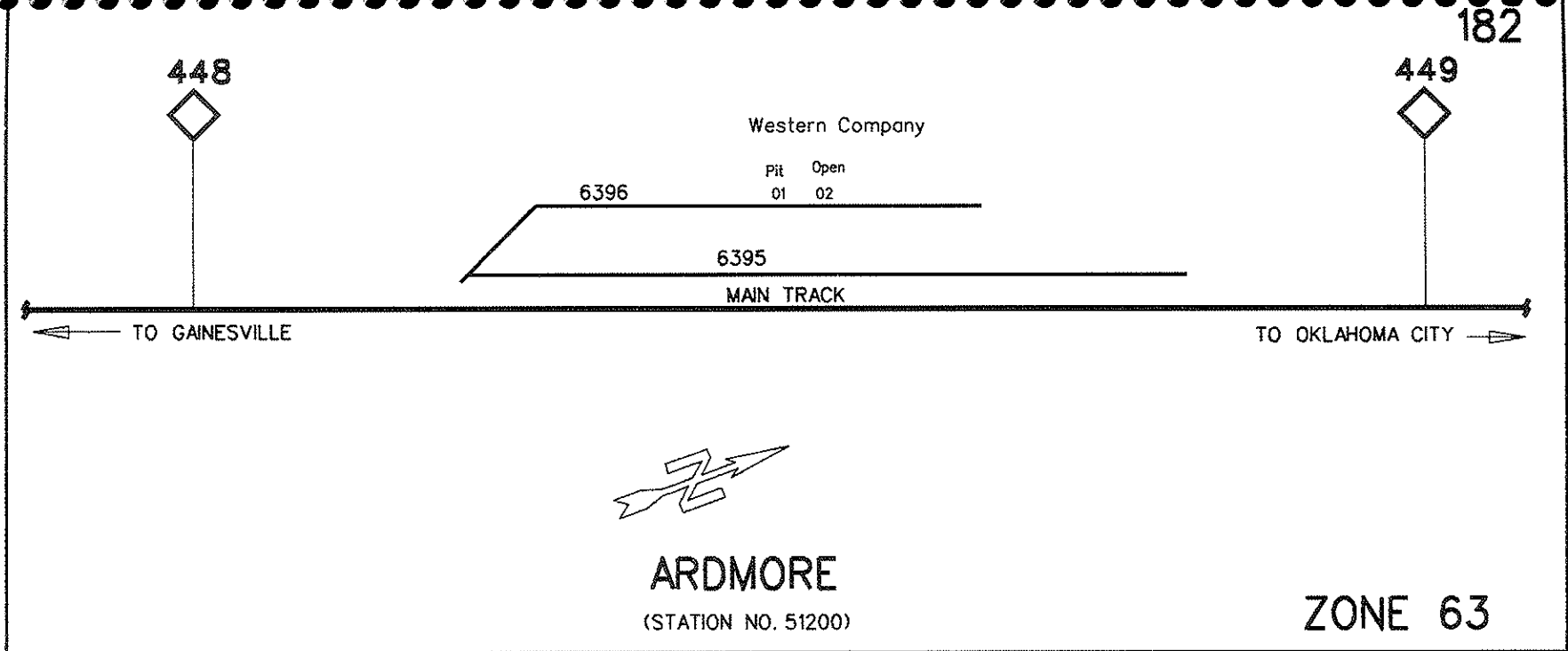

Zone 64 (Overbrook 51140)Oklahoma Subdivision

64 01 00 Overbrook Siding
64 99 00 Main Track

Page 183

C.E.NO.11807-SK Engineering & Technology Development 4/92

184

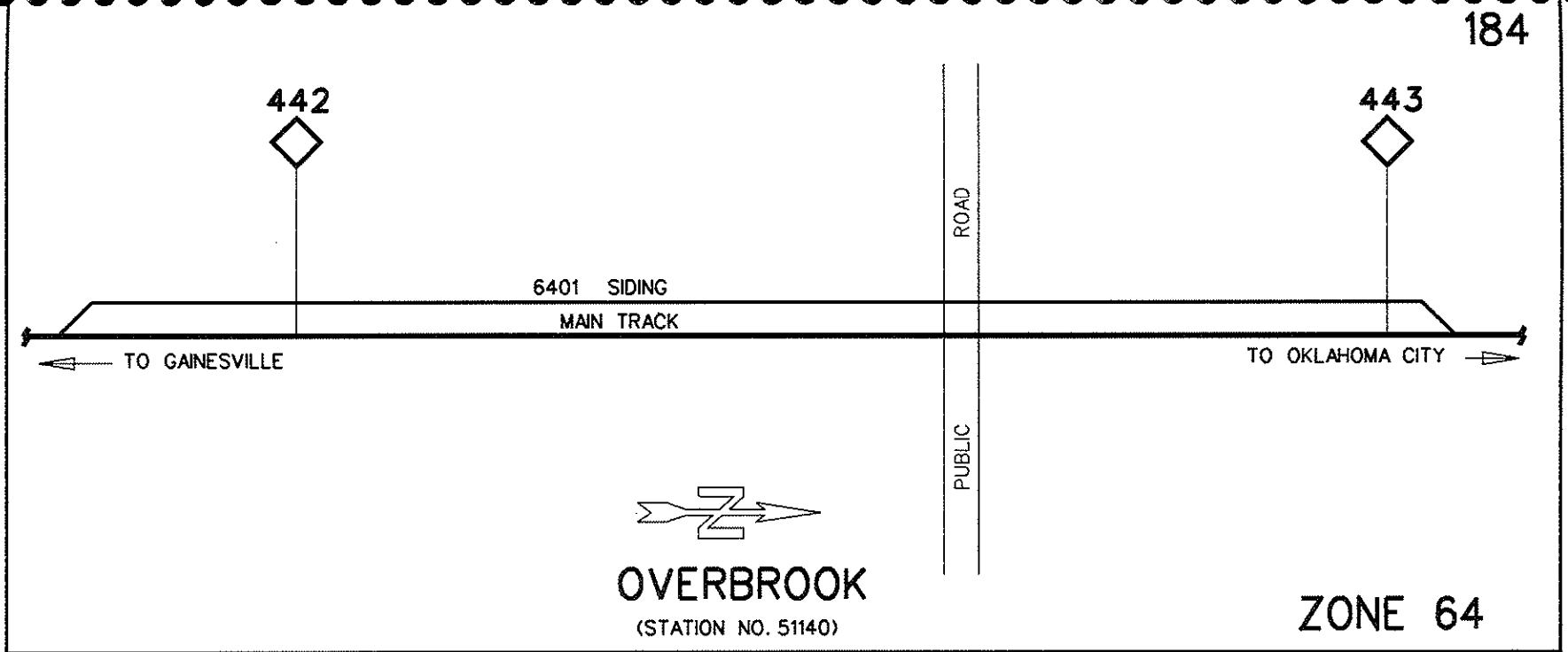

184

ZONE 64

Zone 64 (Marietta 51140) Oklahoma Subdivision

64 02 00	Marietta Siding	
64 03 00	Team Brownie/Mar Fd/Imc Mud	
64 03 01	Team Track Loading (log ldg)	(open)
64 03 02	Little Brownies Bakers	(u.t.auger)
64 03 03	Marietta Feed	(door 1)
64 03 04	Marietta Feed	(door 2)
64 03 05	IMC Drilling Mud	(door 3)
64 03 06	IMC Drilling Mud	(door 4)
64 03 07	Marietta Feed(fertz unldg)	(door 5)
64 05 00	Marietta Gin Spur	
64 05 01	Lains Feed Co	(dock)
64 05 02	R.E.A. Pole Yard	(open)
64 99 00	Main Track	

Page 185

C.E.NO.11807-SK Engineering & Technology Development 4/92

186

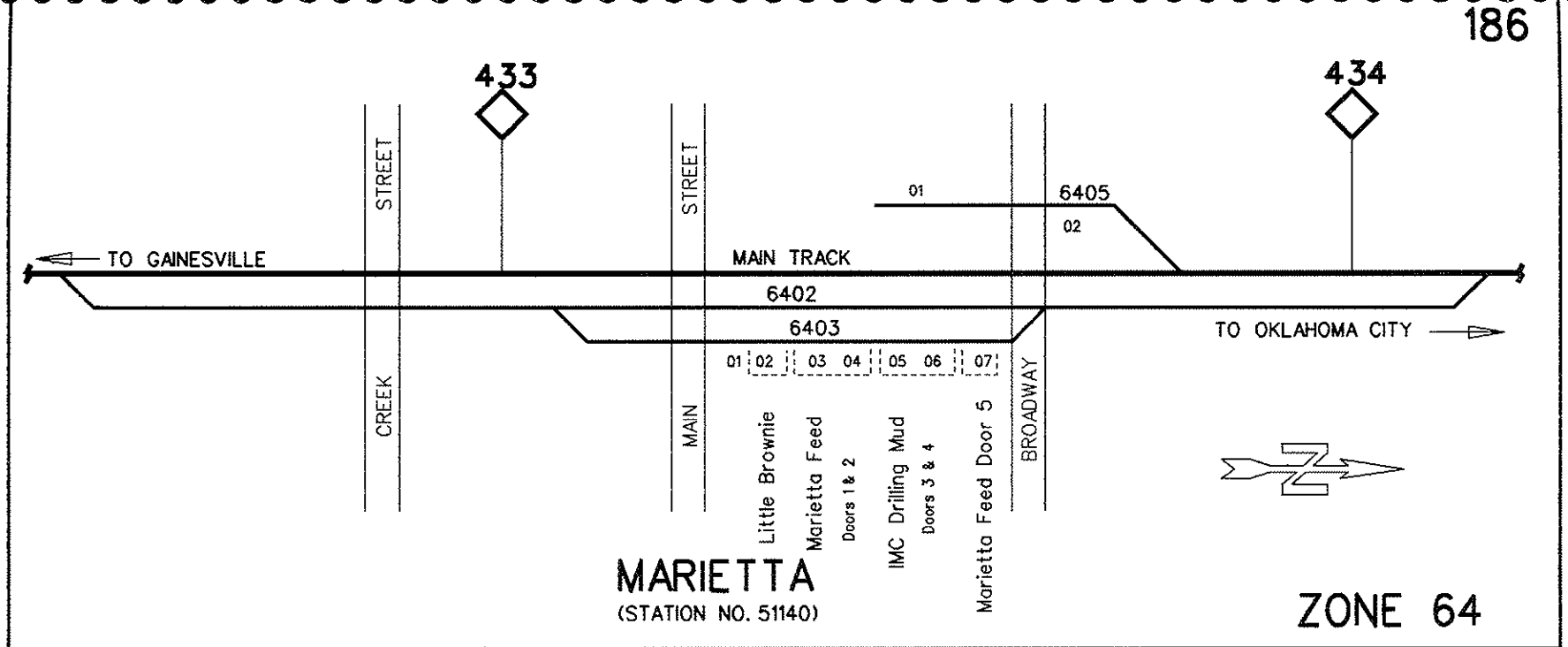

186

Zone 64 (Thackerville 51120) Oklahoma Subdivision

- 64 06 00 Thackerville Yard Track
- 64 07 00 Thackerville Storage Track
- 64 08 00 Thackerville Siding
- 64 99 00 Main Track

Page 187

C.E. NO. 11807-SK Engineering & Technology Development 4/92

188

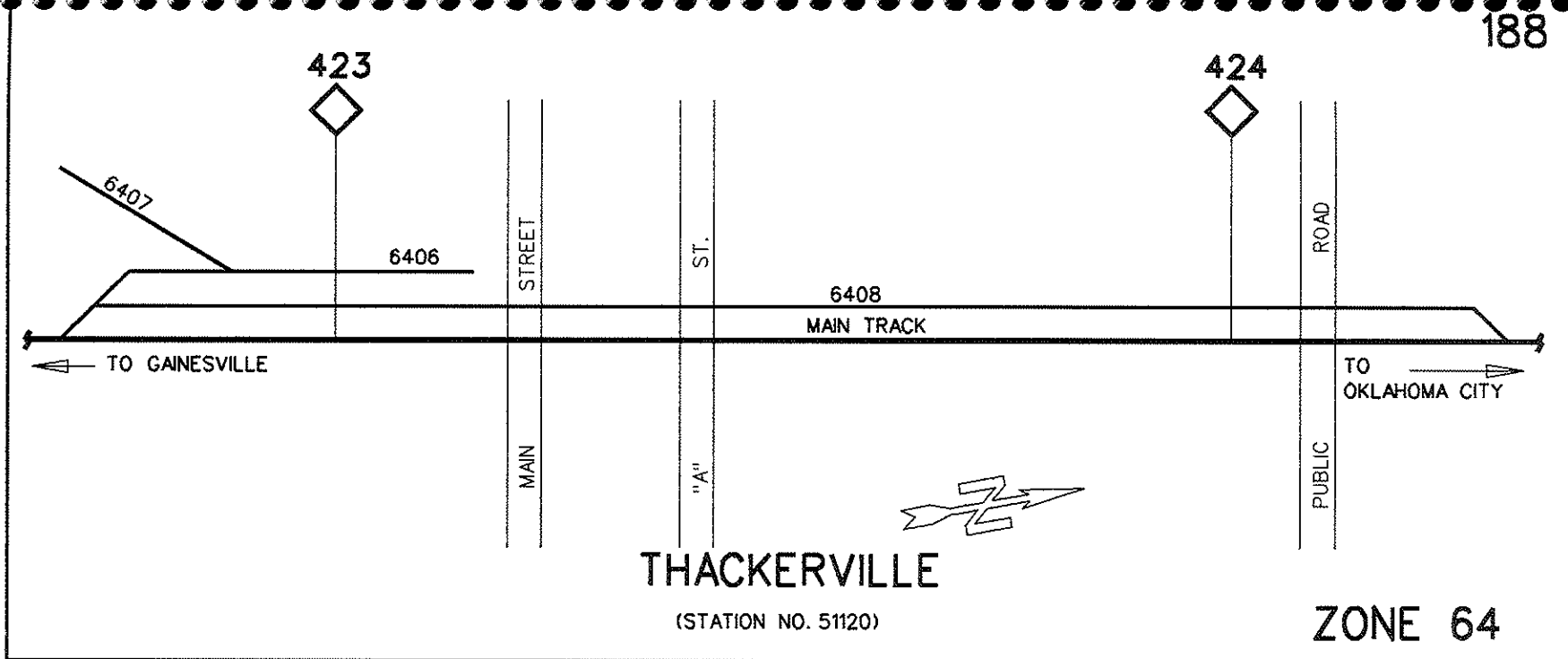

188

Zone 65 (Gainesville 51100) Oklahoma Subdivision

65 01 00	Gainesville Yard Track No. 1	65 21 05	Gainesville Foundry (open)	65 27 00	Tex-O-Fertilizer Track
65 02 00	Gainesville Yard Track No. 2	thru 06		65 27 01	Tex-O-Fertilizer (u.t.pit)
65 03 00	Gainesville Yard Track No. 3	65 23 00	Gainesville Foundry Track 1	65 28 00	Steiner Trk-Tex-O-Fertilizer
65 04 00	Gainesville Yard Track No. 4	65 23 01	Gainesville Foundry (u.t.pit)	65 70 00	East Turn Table Lead Track
65 05 00	Gainesville Yard Track No. 5	65 23 02	Gainesville Foundry (open)	65 95 00	Borden Chemical
65 06 00	Gainesville Yard Track No. 6	65 23 03	Gainesville Foundry (coke bin)	65 96 00	Gville Tail Track No End 6598
65 07 00	Gainesville Yard Track No. 7	65 23 04	Gainesville Foundry (ramp)	65 98 00	Gville Siding No. 60 Track
65 08 00	Gainesville Yard Track No. 8	65 23 05	Gainesville Foundry (open)	65 99 00	Gainesville Main Track
65 09 00	Gainesville East Lead Track	65 25 00	North Wood Furniture Track		
65 10 00	Gainesville East Cab Track	65 25 01	North Wood Furniture (door)		
65 11 00	Gainesville Cut Off Track	thru 02			
65 20 00	National Supply Track				
65 21 00	Gainesville Foundry Track 2				
65 21 01	Gainesville Foundry (open)				
thru 02					
65 21 03	Gainesville Foundry (door)				
thru 04					

C.E.NO.11807-SK Engineering & Technology Development 4/92

190

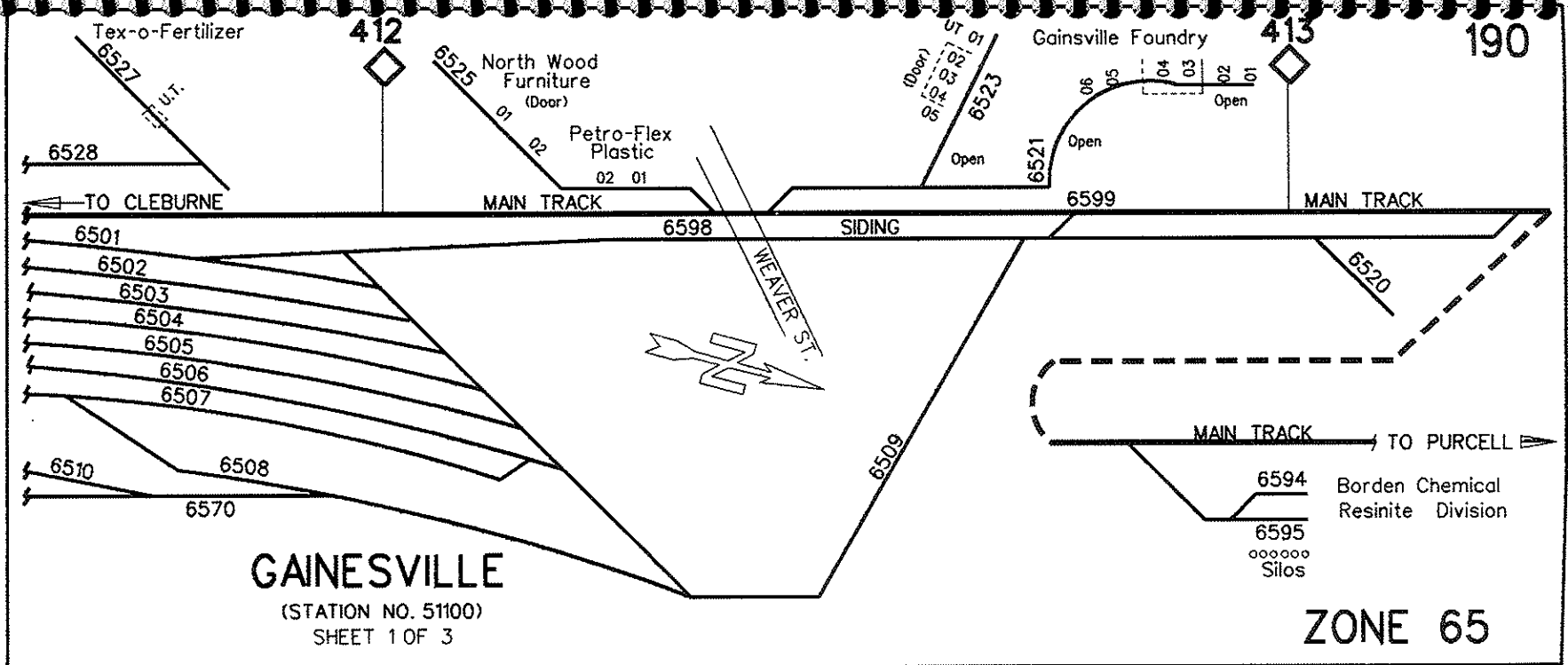

ZONE 65

Zone 65 (Gainesville 51100) Oklahoma Subdivision

65 01 00	Gainesville Yard Track No. 1	65 37 01	Red River Farm	(o.h.spout)
65 02 00	Gainesville Yard Track No. 2	65 37 02	Red River Farm	(door)
65 03 00	Gainesville Yard Track No. 3	thru 03		
65 04 00	Gainesville Yard Track No. 4	65 37 06	Tex-O-Fertilizer	(u.t.pit)
65 05 00	Gainesville Yard Track No. 5	65 38 00	Tony's Feed Store	
65 06 00	Gainesville Yard Track No. 6	65 38 01	Tony's Feed Store	(open)
65 07 00	Gainesville Yard Track No. 7	65 38 02	Tony's Feed Store	(dock)
65 10 00	Gainesville East Cab Track	thru 03		
65 12 00	Gainesville West Cab Track	65 46 00	Old K Main/Liquid Feeds	
65 28 00	Steiner Trk-Tex-O-Fertilizer	65 60 00	West Turn Table Track	
65 28 01	Tex-O-Fertilizer	65 69 00	West Round House Track	
thru 03		65 70 00	East Turn Table Lead Track	
65 30 01	Gainesville Unldg Ramp(ramp)	65 71 00	East Round House Track	
65 31 00	Gainesville Scale Track	65 72 00	Gainesville Oil Spur	
65 37 00	Red River Farm Coop	65 97 00	Gainesville Long Track	
		65 99 00	Gainesville Main Track	

Page 191

C.E. NO. 11807-SK Engineering & Technology Development 4/92

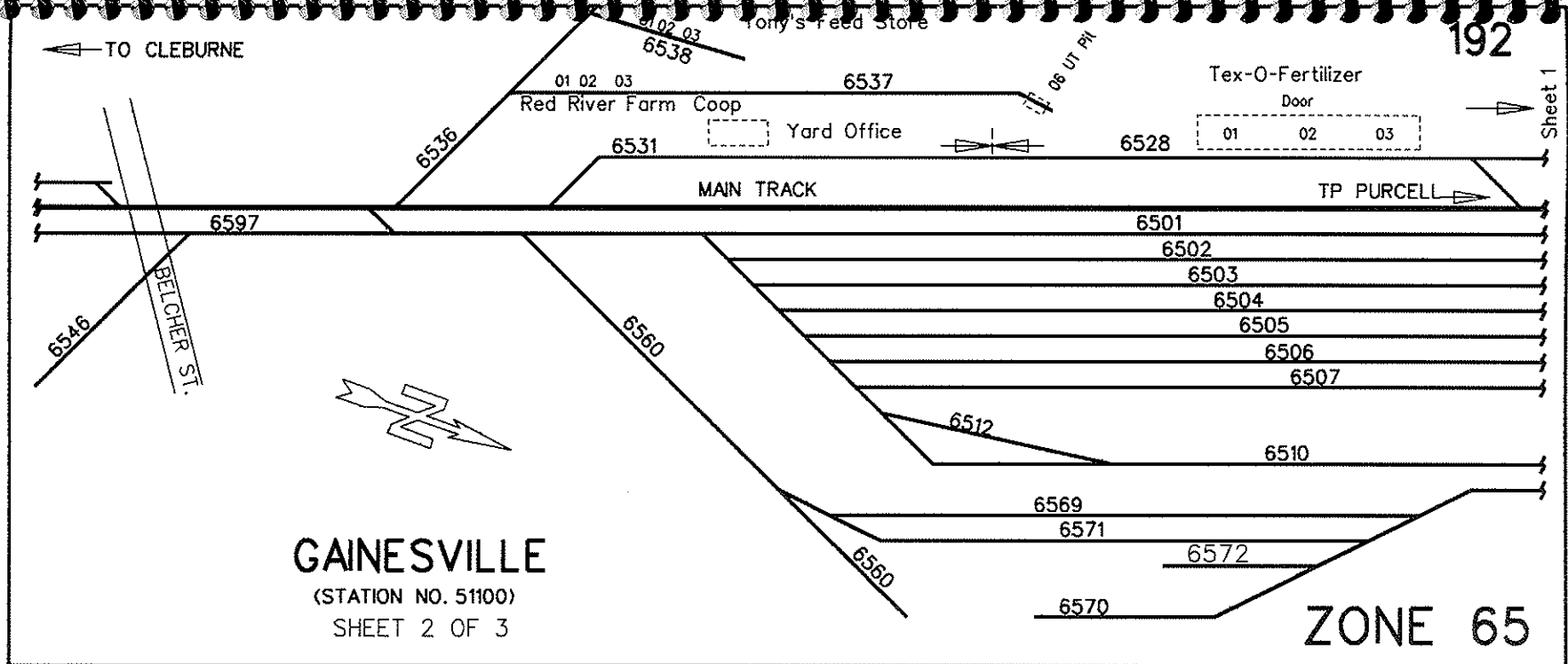

Zone 65 (Gainesville 51100) Oklahoma Subdivision

65 40 00	House Track/Poly Pipe Ind.		65 47 00	Fulton Supply Recycling Track	
65 40 01	Arco	(dock)	65 47 01	Fulton Supply Recycling	(open)
thru 02			thru 03		
65 40 03	Poly Pipe	(open)	65 48 00	North Track/Liquid Blenders	
thru 04			65 48 01	Liquid Blenders	(pump)
65 40 05	Gulf Oil Co	(dock)	65 48 02	Farm Products	(u.t.pit)
thru 06			thru 05		
65 40 07	Dowell Chemical Co	(open)	65 48 06	Farm Products	(o.h.suction pipe)
65 40 08	House Dock Unloading	(dock)	65 49 00	Middle Track/Liquid Blenders	
65 42 00	Gainesville South Team Track		65 49 01	Vacant	(dock)
65 42 01	South Team Track Unldg	(open)	thru 02		
65 46 00	Old K Main/Liquid Feeds		65 50 00	South Track	
65 46 01	Munster Mill	(pump)	65 50 01	Vacant	(o.h.spout)
65 46 02	Liquid Blenders	(pump)	65 97 00	Gainesville Long Track	
			65 99 00	Gainesville Main Track	

C.E. NO. 11807-SK Engineering & Technology Development 4/92

194

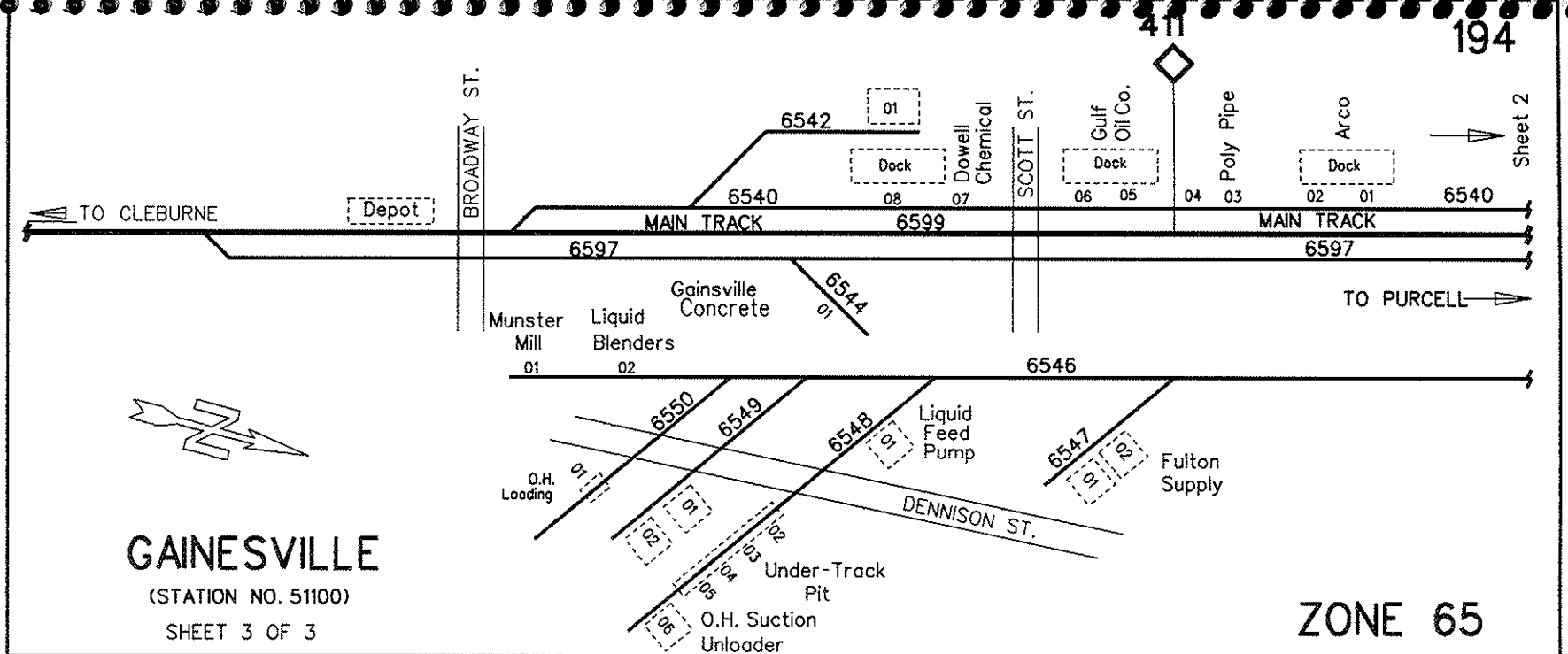

ZONE 65

Zone 50 (Stillwater 52120) Stillwater Subdivision

50 01 00	Armstrong		50 05 00	Back Track	
50 01 01	Armstrong	(auger)	50 06 00	Runaround track	
thru 02			50 07 00	National Standard	
50 01 03	Armstrong	(door)	50 07 01	National Standard	(dock)
thru 04			thru 06		
50 02 00	Armstrong		50 08 00	Oberlin Color Press Track	
50 03 00	Mercury Marine		50 08 01	Oberline Color Press	(dock)
50 03 01	Mercury Marine	(dock)	50 09 00	Oberline Color Press Track	
thru 04			50 09 01	Oberline Color Press	(dock)
50 04 00	Moore Business Forms		50 99 00	Main Track	
50 01 01	Moore Business Forms	(door)			
thru 09					

Page 195

C.E. NO. 12619-SK Engineering & Technology Development 4/92

196

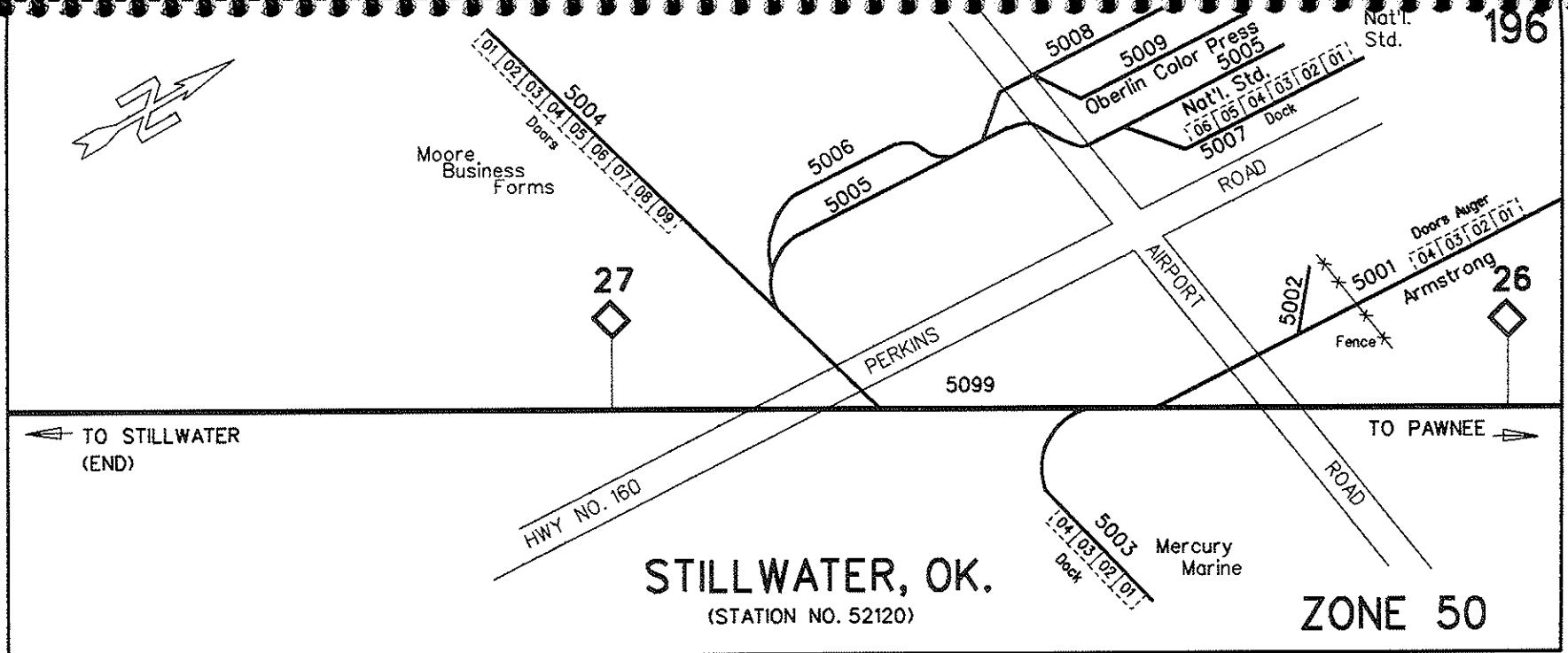

Zone 50 (Stillwater 52120) Stillwater Subdivision

50 11 00	Boersman Beverage Spur		50 13 11	Stillwater Milling	(door)
50 11 05	Boersma Beverage Co	(door)	50 14 00	Team	
thru 07			50 14 01		(open)
50 12 00	Stillwater Milling		thru 04		
50 12 01	Stillwater Milling	(door)	50 15 00	Ahrberg Milling Spur	
thru 08			50 15 01	Ahrberg Milling	(open)
50 13 00	Stillwater Milling		thru 10		
50 13 01	Stillwater Milling	(oh ldg)	50 16 00	House Track	
thru 10			50 98 00	Siding	
			50 99 00	Main Track	

Page 197

CE NO. 12619-SK Engineering & Technology Development 4/92

198

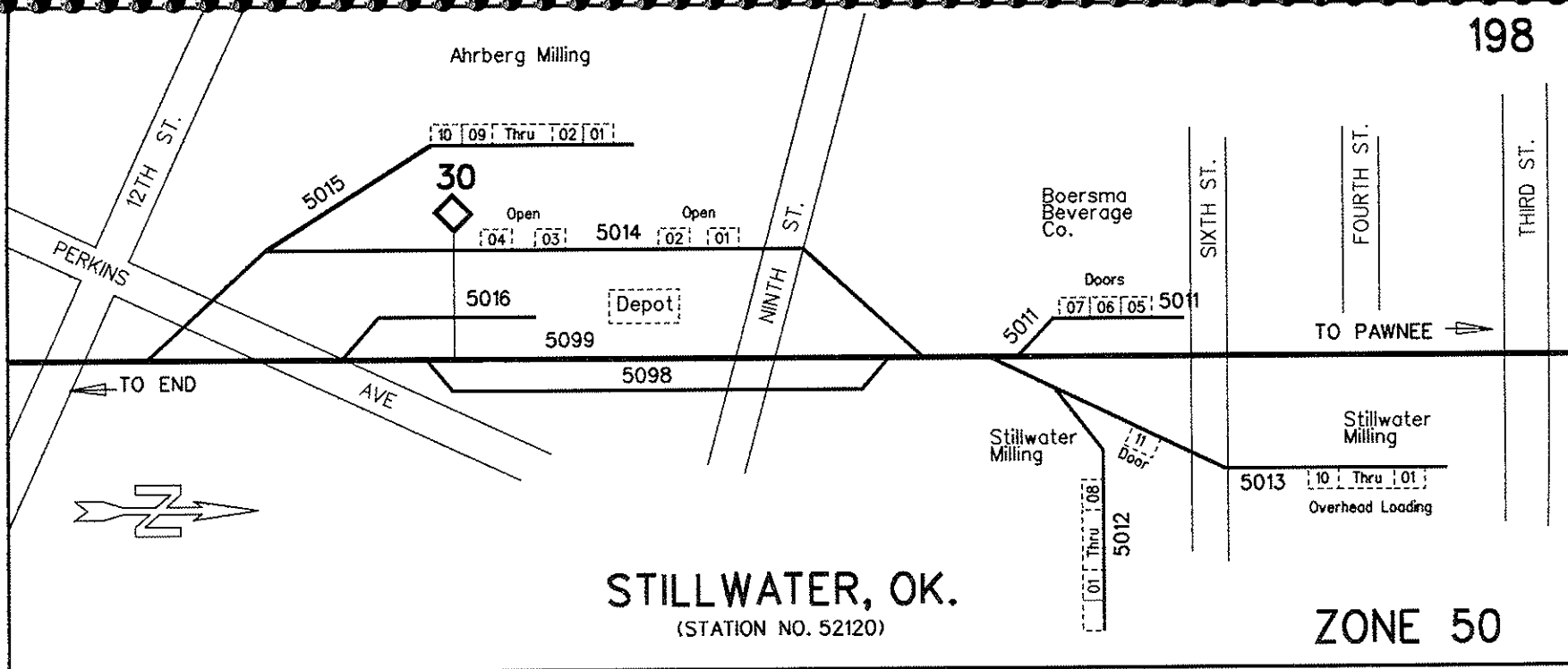

198

STILLWATER, OK.
(STATION NO. 52120)

ZONE 50

Zone 52 (Glencoe 52115) Stillwater Subdivision

52 01 00 Setout Spur
52 99 00 Main Track

Page 199

C.E. NO. 12619-SK Engineering & Technology Development 4/92

200

200

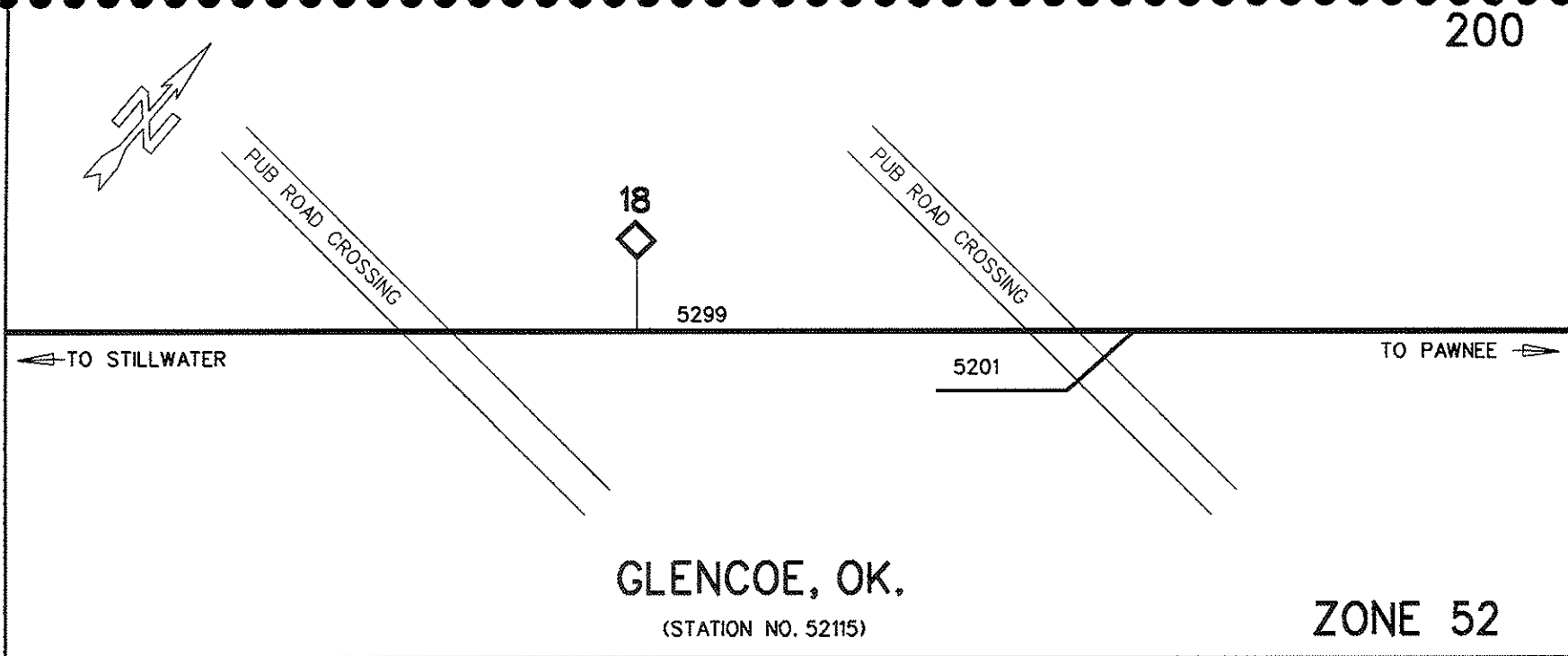

Zone 54 (Pawnee 52110) Stillwater Subdivision

54 01 00	Team Track		54 04 00	Stockmans Mill	
54 01 01		(open)	54 04 01	Stockmans Mill & Grain	(spout)
thru 04			thru 02		
54 02 00	House Track		54 04 03	Stockmans Mill & Grain	(door)
54 02 01		(open)	thru 05		
thru 02			54 04 06	Stockmans Mill & Grain	(open)
54 02 03	House	(dock)	54 05 00	BN Connection	
54 03 00	Dock		54 99 00	Main Track	
54 03 01		(dock)			

Page 201

C.E. NO. 12619-SK Engineering & Technology Development 4/92

202

202

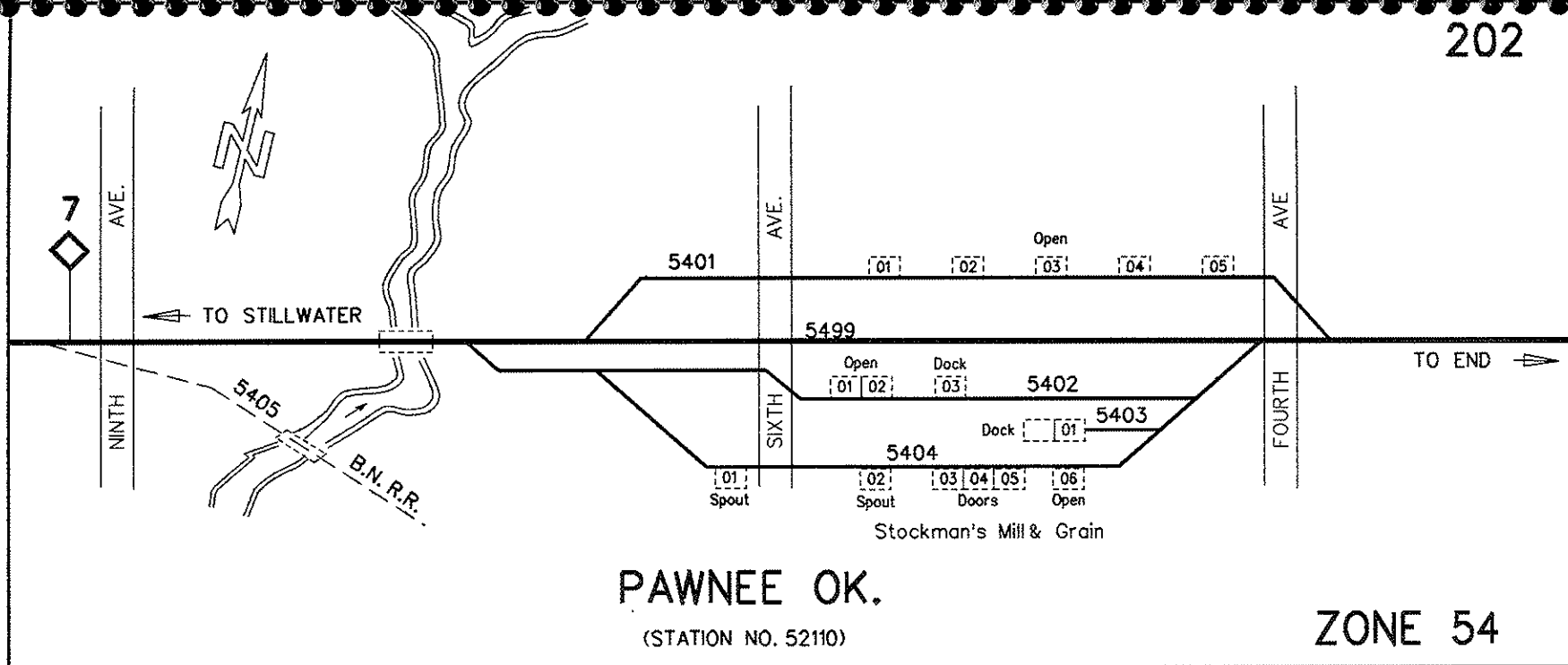

PAWNEE OK.

(STATION NO. 52110)

ZONE 54

Zone 08 (Kiowa 54100) Enid Subdivision

20 46 00	Kiowa Siding	(18640 ft)	20 55 00	Kiowa Middle No 1 Track	
20 47 00	East No 1 Track	(1750 ft)	20 56 00	West No 1 Track	(2000 ft)
20 48 00	East No 2 Track	(1280 ft)	20 57 00	West No 2 Track	(2000 ft)
20 49 00	East No 3 Track	(800 ft)	20 58 00	Kiowa Stock Track	(250 ft)
20 50 00	Kiowa Elevator Track		20 58 01	Crane Ammonia Coop	(o.h.pump)
20 50 01	O K Coop Elev	(open)	20 58 02	O K Coop Fert	
20 50 02	O K Coop Elev	(o.h. spout)	20 59 00	Kiowa Stock Extension	
20 50 03	O K Coop Elev	(ut auger)	20 62 00	Kiowa Passenger Spur	
20 50 04		(dock)	20 63 00	Kiowa House Track	
20 50 05	O K Coop Elev	(door)	20 63 01	O K Coop Elebator	(o.h. spout)
20 50 07	Michael Oil Co	(dock)	20 64 00	Kiowa Halliburton Spur	
20 51 00	Kiowa No 1 Pocket (80 ft)		20 65 00	Kiowa 3rd Leg of Wye	
20 52 00	Kiowa No 2 Pocket (550 ft)		20 66 00	Kiowa West Leg of Wye	
20 53 00	Kiowa No 3 Elevator Track		20 98 00	Kiowa East Leg Wye to Enid	
20 54 00	Kiowa No 4 Elevator Track		20 99 00	Kiowa Main Track	
20 54 01	O K Coop Elevator	(o.h. spout)			

Page 203

204

C.E.NO:12619-SK Engineering & Technology Development 4/92

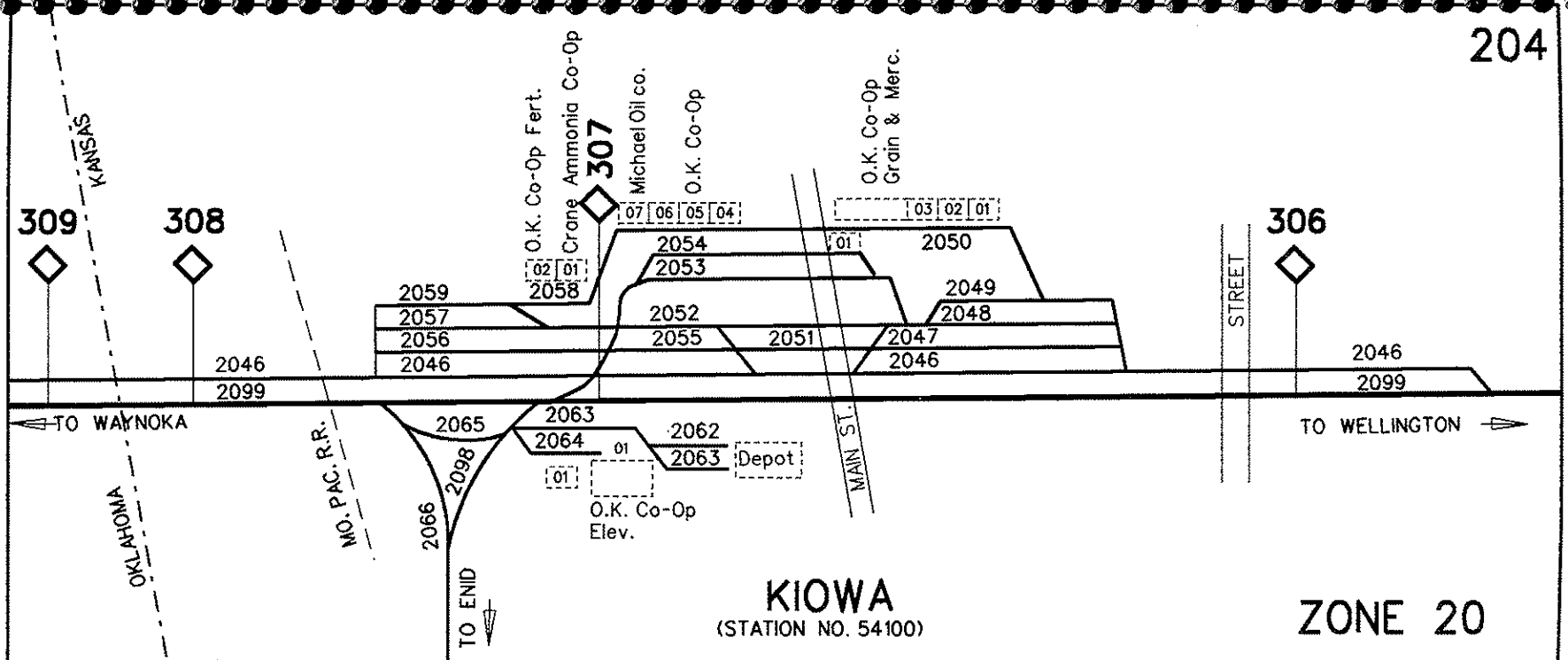

KIOWA
(STATION NO. 54100)

ZONE 20

Zone 19 (Burlington 51870) Enid Subdivision

19 01 00	Burlington Elev Track	
19 01 01	Coop Feed Mill	(door)
19 01 02	Coop Feed Mill	(fertz pit)
19 01 03	Coop Elevator A	(spout)
19 01 04	Coop Elevator B	(spout)
19 01 05	Coop Liquid Fertz	(hose)
19 01 10	Elevator Track	(open)
19 02 00	Siding East End	
19 02 01		(open)
19 03 00	Siding West End	
19 03 01		(open)
19 99 00	Main Track	

Page 205

CE NO. 12619-SK Engineering & Technology Development 4/92

206

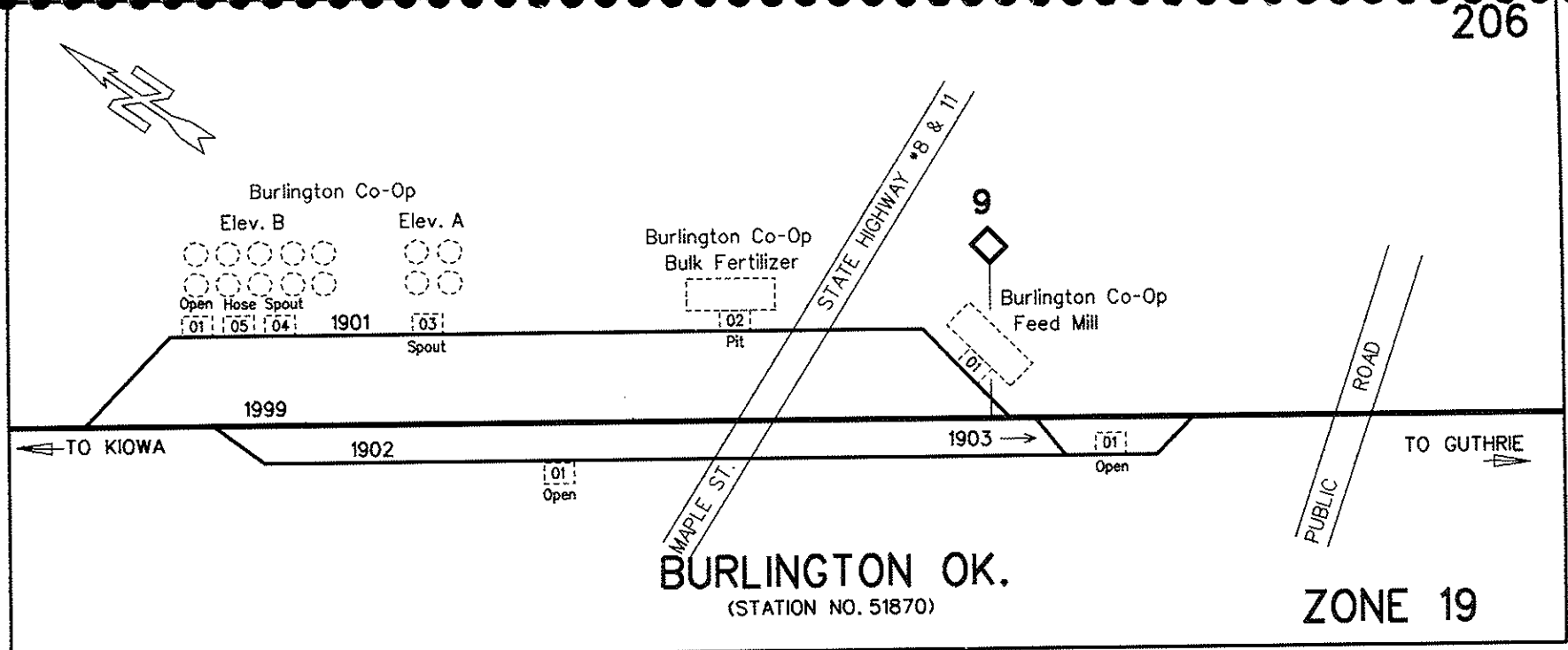

206

BURLINGTON OK.
(STATION NO. 51870)

ZONE 19

Zone 20 (Cherokee 51850) Enid Subdivision

20 01 00 New Siding Cherokee
20 02 00 Stock Track Cherokee
20 99 00 Main Track - Enid Subdivision

Page 207

C.E. NO. 12619-SK Engineering & Technology Development 4/92

208

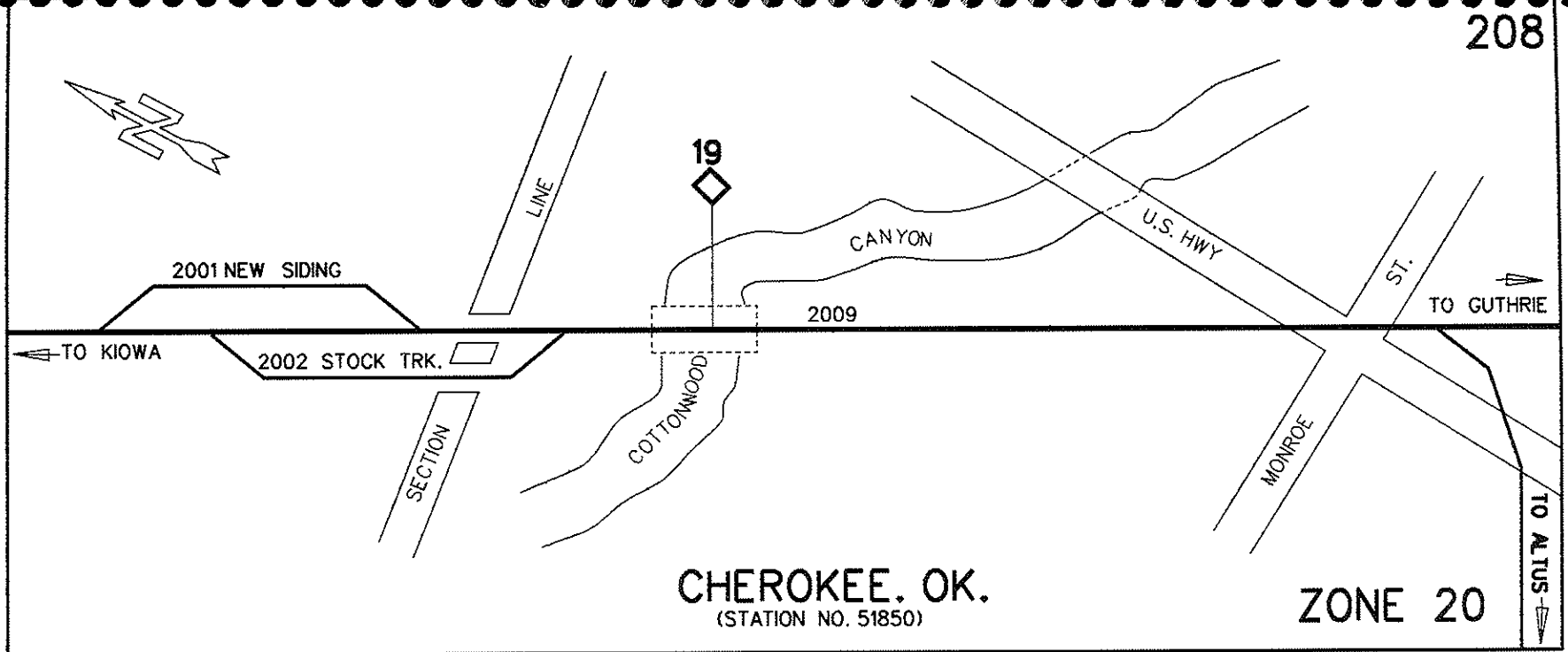

Zone 20 (Cherokee 51850) Enid Subdivision

20 04 00	Orient House Track		20 07 00	Farmers Cook Elev C Cherokee	
20 04 01	Scrap Loading	(open)	20 07 01	Farmers Coop Elev C	(spout)
20 04 10	Farmers Coop Liquid Fertilizer	(hose)	20 08 00	Mill Track Cherokee	
20 04 20	Farmers Coop Elev E	(spout)	20 08 01	Farmers Coop Dry Fertz	(pit)
20 04 30	Farmers Coop Feed Warehouse	(door)	20 08 02	Farmers Coop Warehouse	(door)
20 04 45	Farmers Coop	(open)	20 08 03	Farmers Coop Elev E	(spout)
20 05 00	Orient Siding		20 08 10	Farmers Coop Elev B	(spout)
20 05 01			20 99 00	Main Track - Enid Subdivision	

C.E. NO. 12619-SK Engineering & Technology Development 4/92

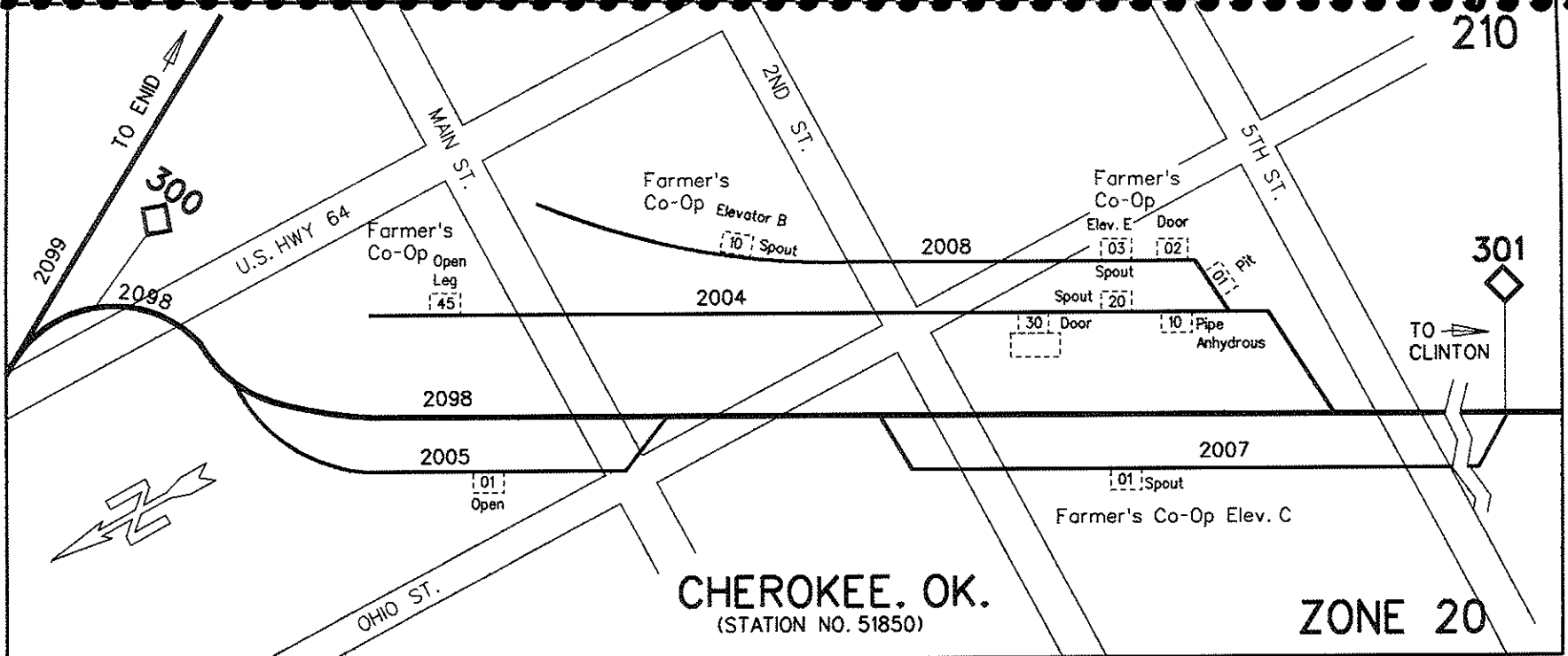

Zone 20 (Cherokee 51850) Enid Subdivision

20 10 00	Long House Cherokee	
20 12 00	Cross Track Cherokee	
20 14 00	Short House Cherokee	
20 14 01	Team	(open)
20 14 10	Team	(dock)
20 98 00	Main Track - Altus Subdivision	
20 99 00	Main Track - Enid Subdivision	

Page 211

C.E. NO. 12619-SK Engineering & Technology Development 4/92

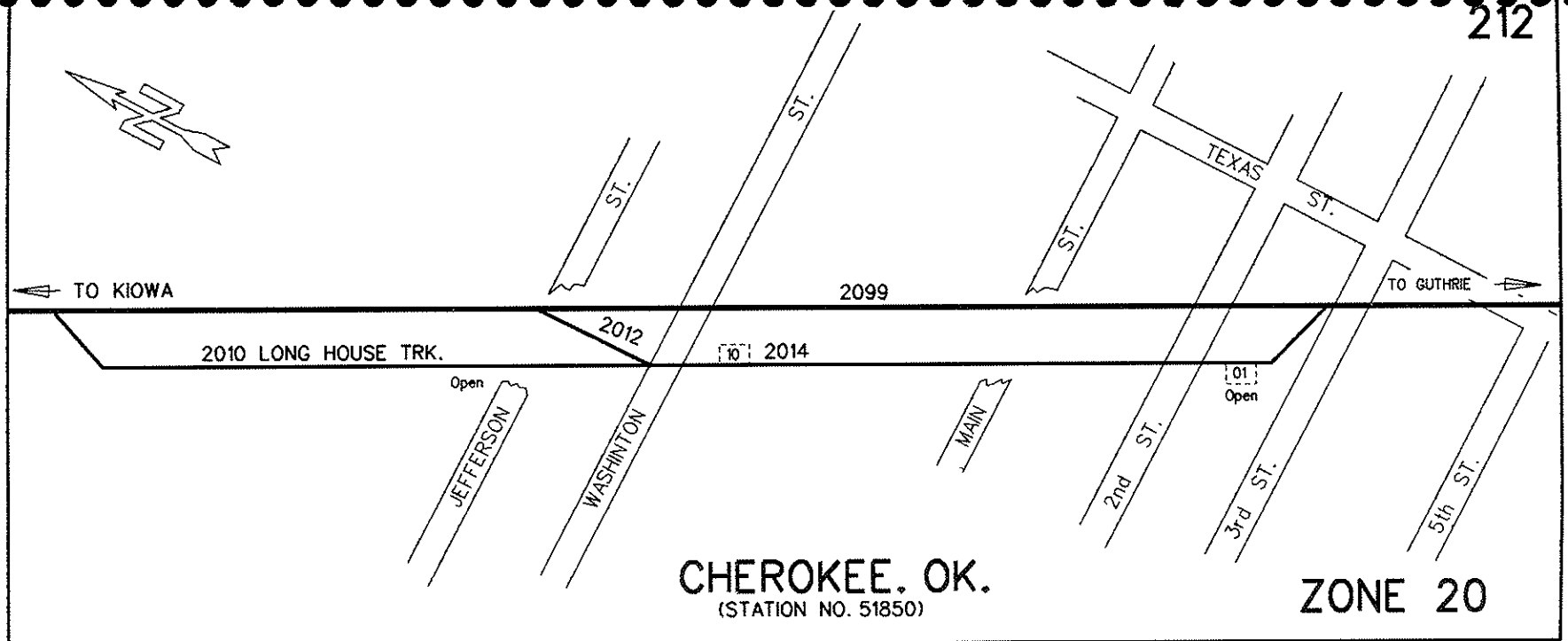

212

Zone 32 (Jet 51840) Enid Subdivision

32 01 00	Jet House Track	
32 01 01	Team Track Patrons	(open)
32 01 10	Farmers Coop (bulk fertilizer)	(pit)
32 02 00	Siding	
32 02 01	Farmers Coop Elevator 2	(spout)
thru 03		
32 03 00	Jet Elevator Spur	
32 03 01	Farmers Coop Elevator 1	(door)
32 03 02	Farmers Coop Elevator 2	(spout)
32 99 00	Main Track	

Page 213

C.E. NO. 12619-SK Engineering & Technology Development 4/92

214

214

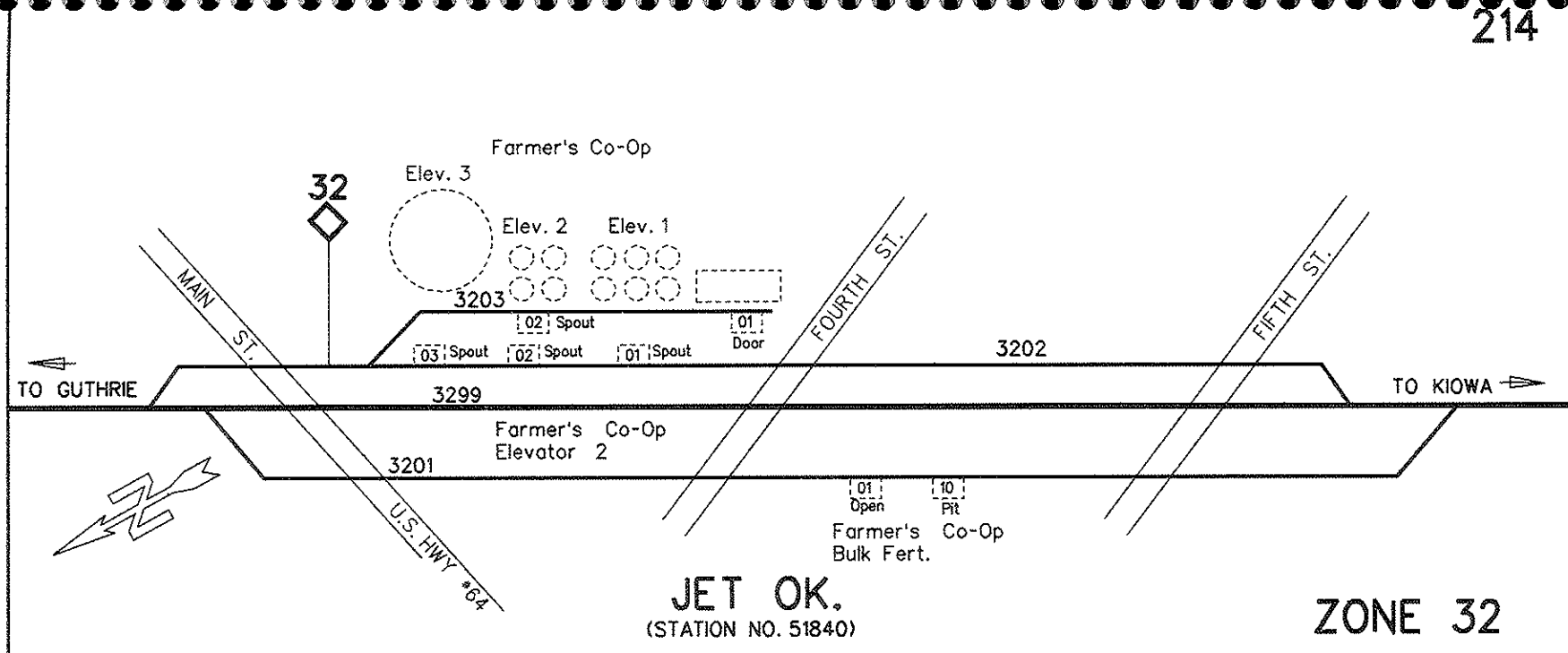

Zone 40 (Nash 51830) Enid Subdivision

40 01 00	Nash House Track	
40 01 01	Nash Equity	(door)
40 01 02	(fertilizer pit)	
40 01 03	Team Track Patrons	(dock)
40 01 10	Nash Equity South Elevator	(spout)
40 01 11	Nash Equity North Elevator	(spout)
40 02 00	Nash Siding	
40 99 00	Main Track	

Page 215

C.E. NO. 12619-SK Engineering & Technology Development 4/92

216

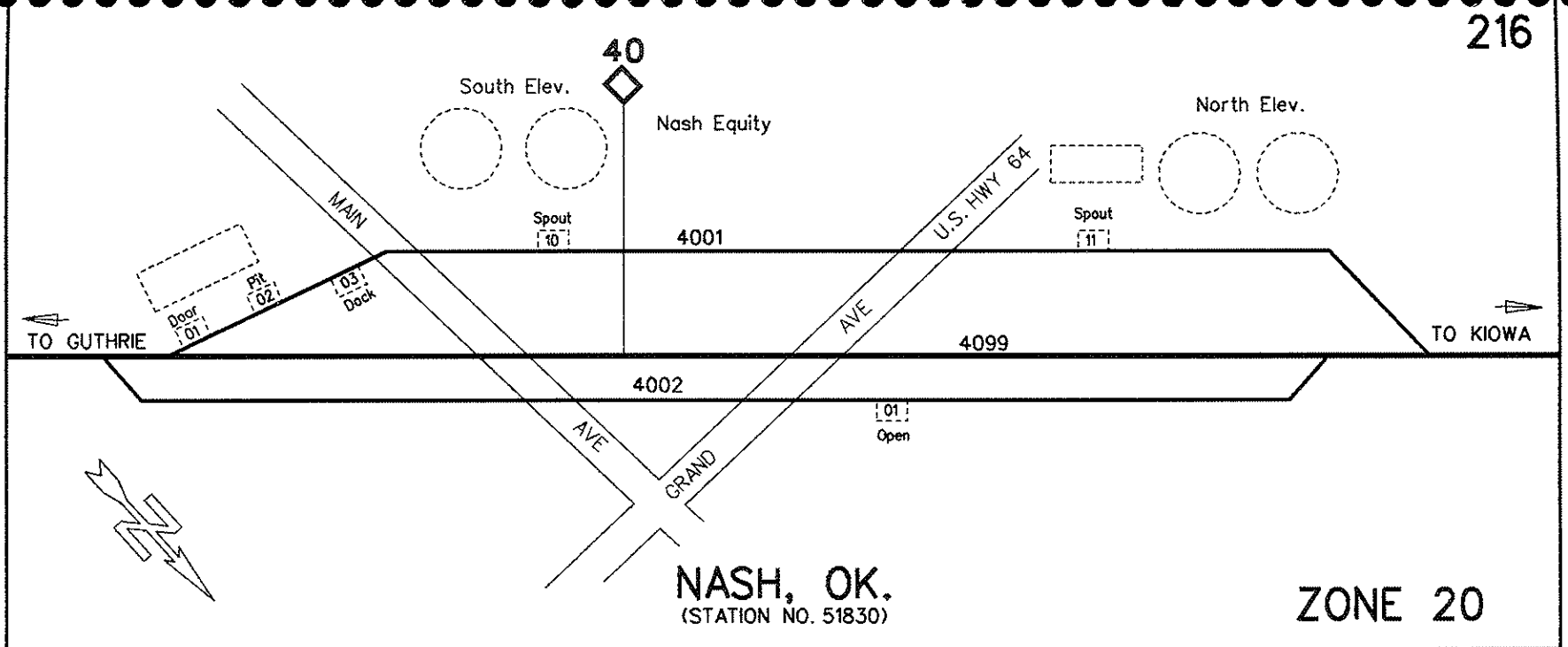

Zone 48 (Hillsdale 51820) Enid Subdivision

48 01 00	Hillsdale Elevator Track	
48 01 01	Hillsdale Coop	(spout)
48 01 02	Hillsdale Coop	(dock)
48 01 10	Hillsdale Coop	(spout)
thru 11		
48 01 15	Hillsdale Coop	(hose)
48 01 20		(open)
48 02 00	Siding Hillsdale	
48 99 00	Main Track	

Page 217

C.E. NO. 12619-SK Engineering & Technology Development 4/92

218

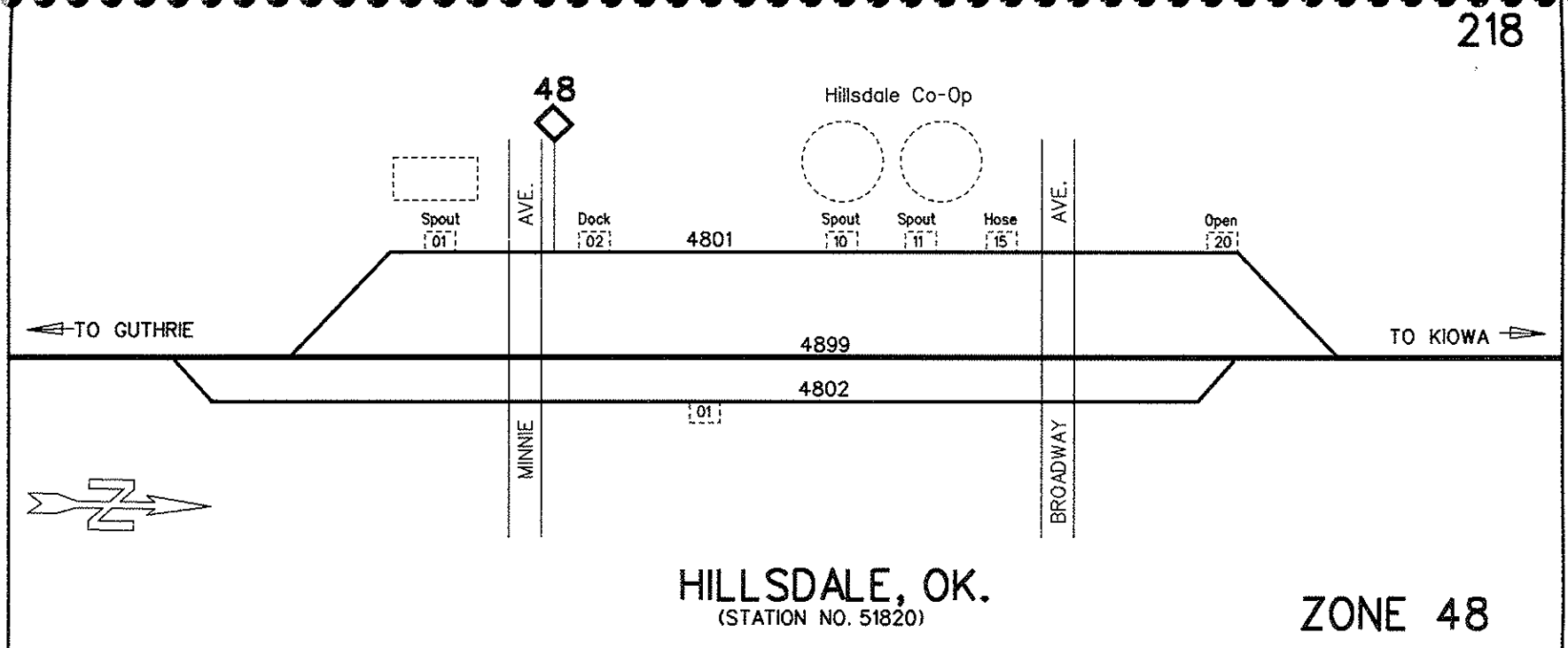

Zone 58 (Blanton 51810) Enid Subdivision

58 01 00 Blanton Siding
58 01 01 (open)
58 99 00 Main Track Blanton

Page 219

C.E. NO. 12619-SK Engineering & Technology Development 4/92

220

220

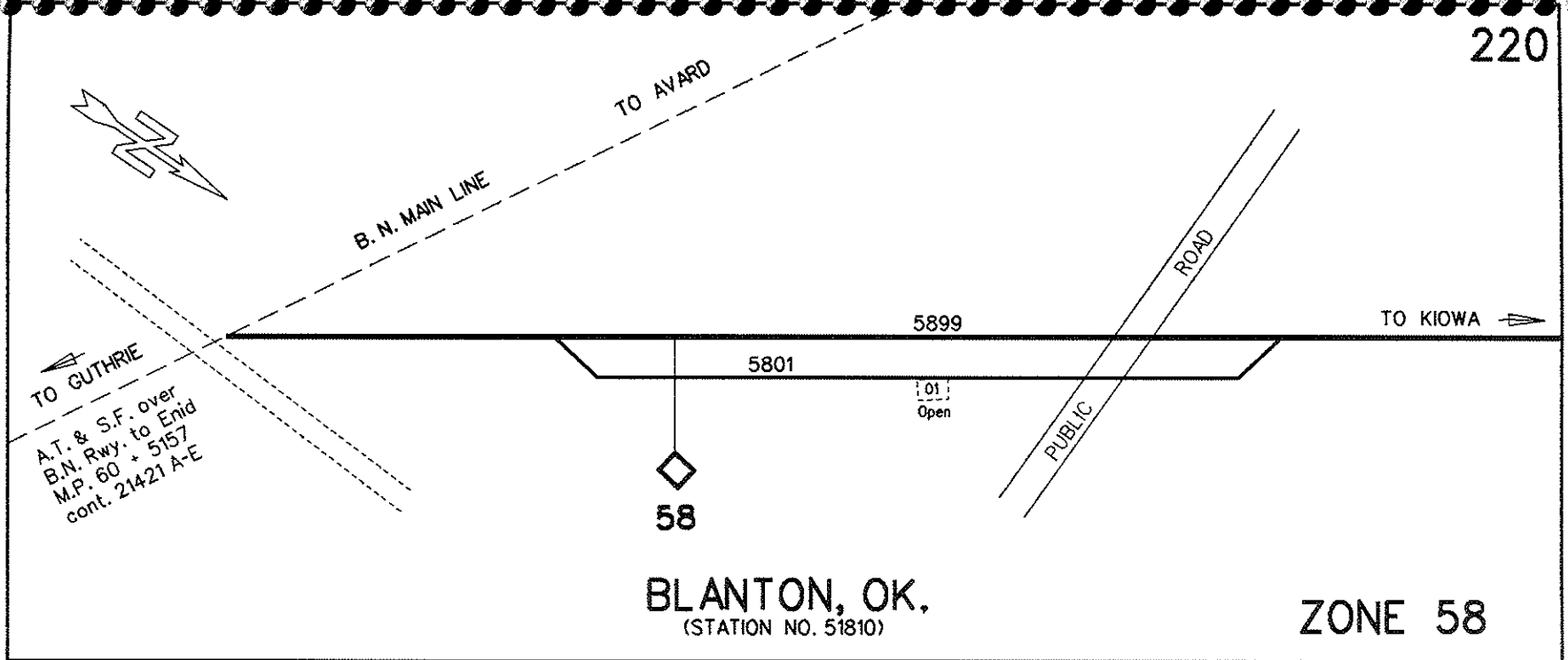

BLANTON, OK.
(STATION NO. 51810)

ZONE 58

Zone 81 (Enid 51800) Enid Subdivision

81 01 00	Yard Track 1 - BN Interchange	81 12 00	Yard Track 12
81 02 00	Yard Track 2 - BN Interchange	81 13 00	Yard Track 13
81 03 00	Yard Track 3	81 14 00	Yard Track 14
81 04 00	Yard Track 4	81 15 00	Yard Track 15
81 05 00	Yard Track 5	81 16 00	Yard Track 16
81 06 00	Yard Track 6	81 17 00	Tail Track
81 07 00	Yard Track 7	81 20 00	Rip Track
81 08 00	Yard Track 8	81 21 00	Roundhouse
81 09 00	Yard Track 9	81 60 00	Yard Track 8 1/2
81 10 00	Yard Track 10	81 99 00	Main Track
81 11 00	Yard Track 11		

Page 221

C.E. NO. 12619-SK Engineering & Technology Development 4/92

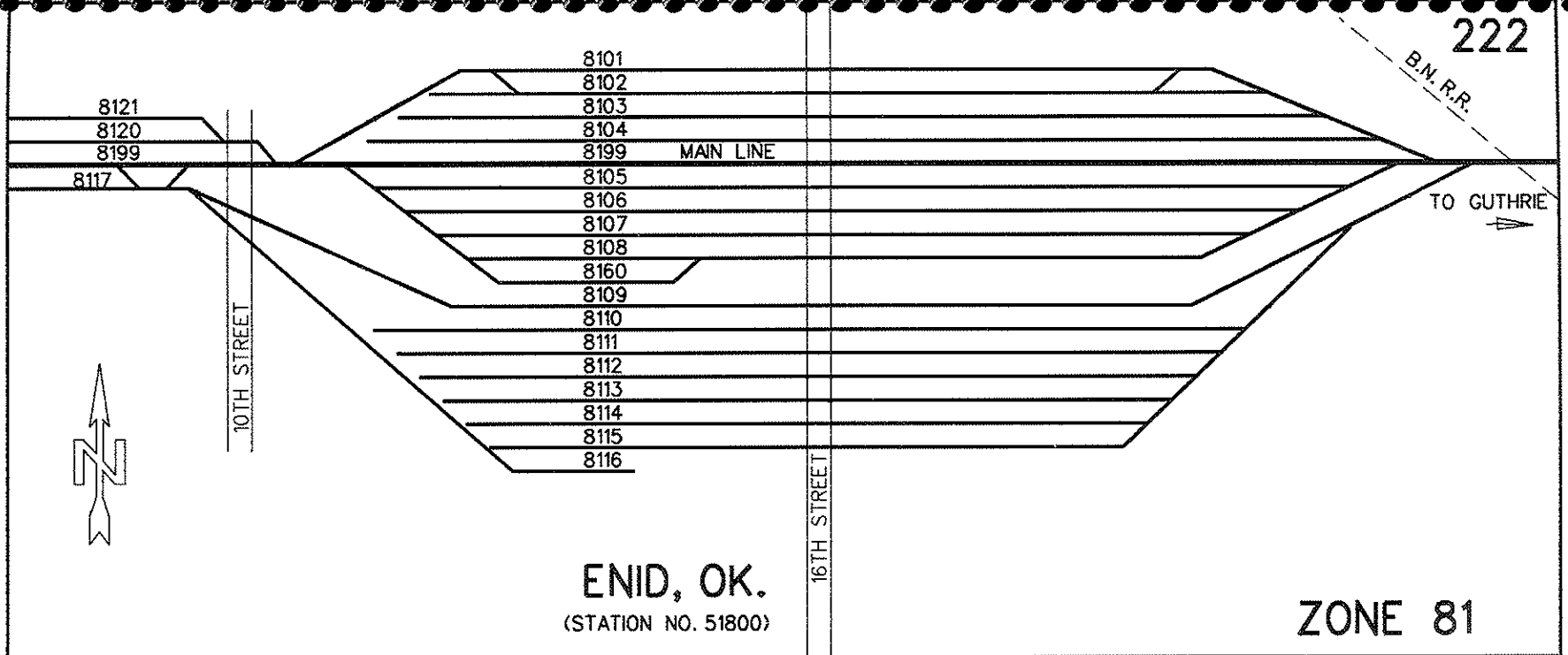

222

Zone 81 (Enid 51800) Enid Subdivision

81 09 00	Yard Track 9	
81 10 00	Yard Track 10	
81 17 00	Tail Track	
81 18 00	Old UP Interchange	
81 19 00	Old UP Interchange	
81 20 00	South Roundhouse	
81 21 00	North Roundhouse	
81 22 00	Sand Track	
81 22 01	Sand Track	(sand)
81 23 00	South Leg Wye	
81 24 00	West Leg Wye	
81 25 00	North Leg Wye	
81 99 00	Main Track	

Page 223

C.E. NO. 12691-IN Engineering & Technology Development 4/92

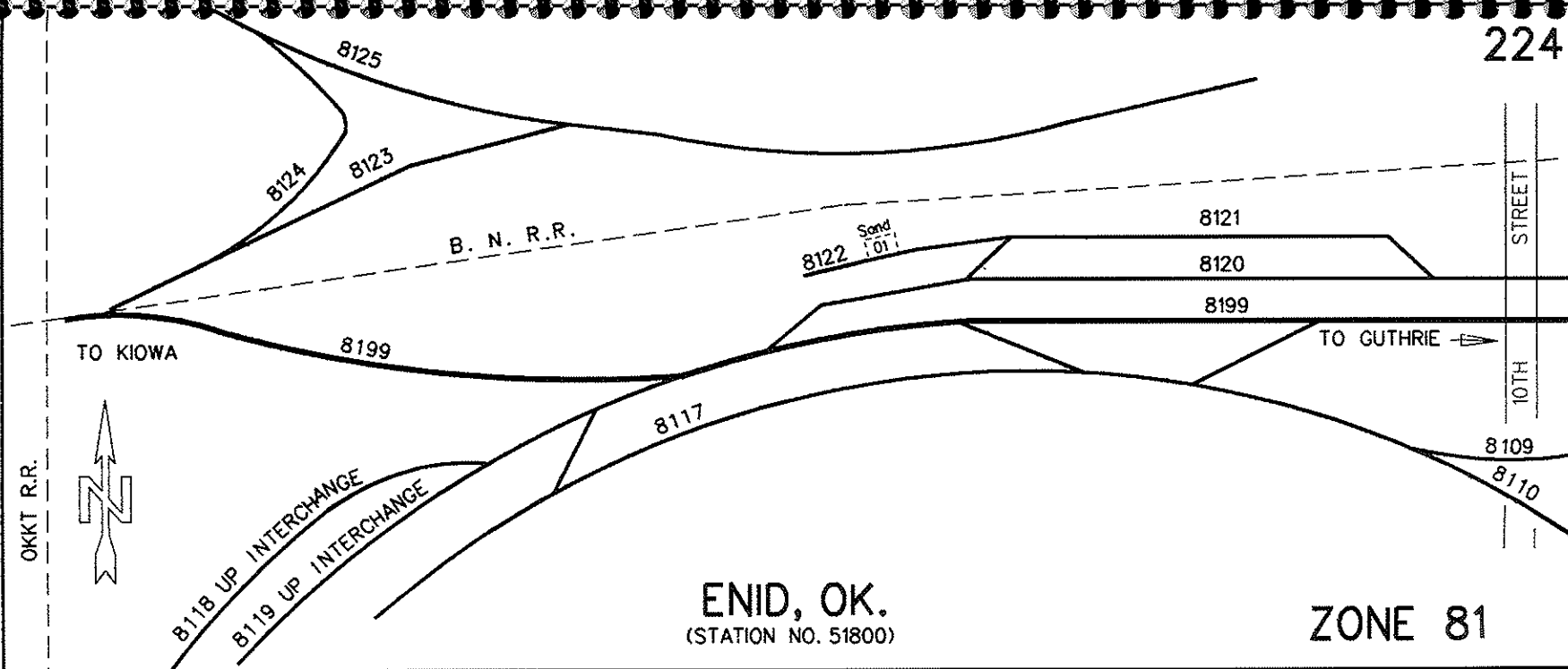

224

224

STREET

10TH

8109

8110

ENID, OK.
(STATION NO. 51800)

ZONE 81

Zone 82 (Enid 51800) Enid Subdivision

82 01 00	Big Rack
82 02 00	Rip 1
82 03 00	Rip 2
82 04 00	South Pass
82 05 00	South House
82 06 00	North House Track
82 07 00	Lube Rack - Roll Track
82 08 00	North Pass
82 10 00	Propane Rack
82 99 00	Main Track

Page 225

C.E. NO. 12691-IN Engineering & Technology Development 4/92

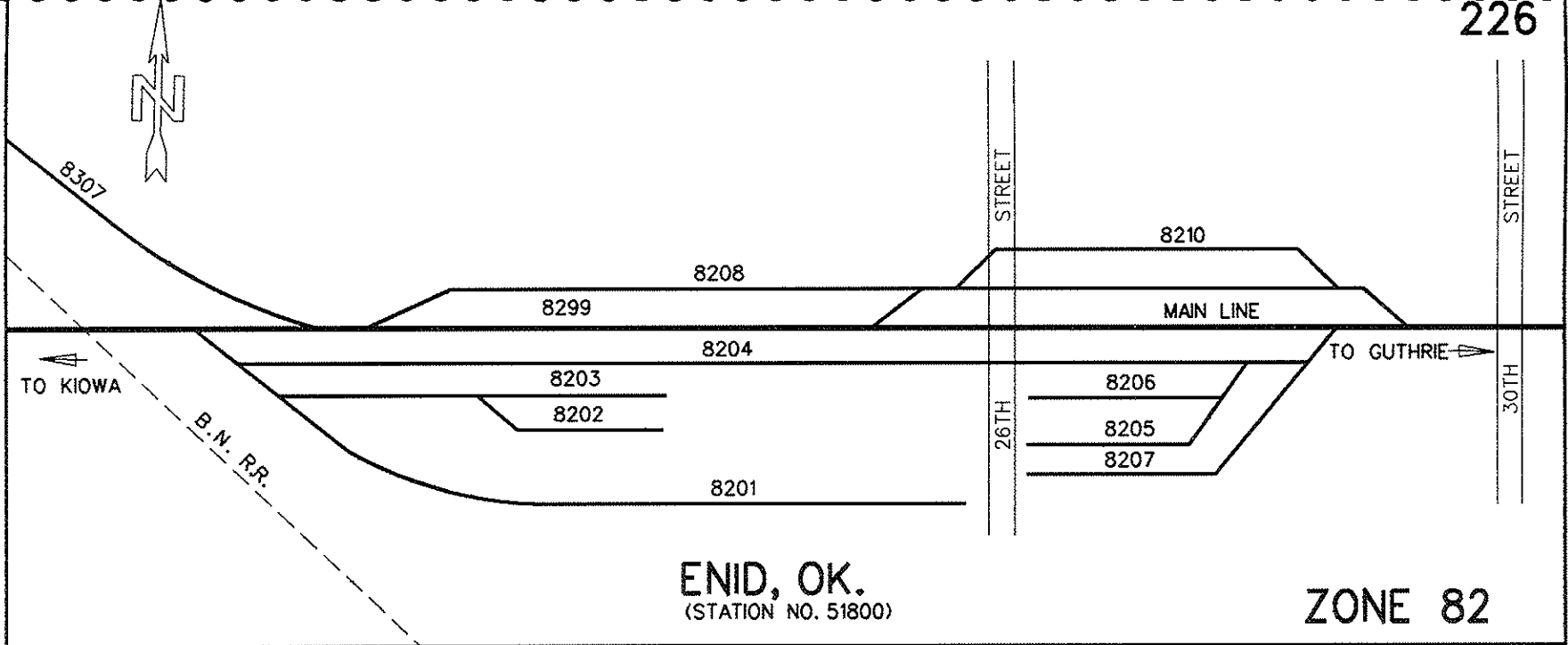

226

226

ENID, OK.
(STATION NO. 51800)

ZONE 82

Zone 83 (Enid 51800) Mid America Grain

83 01 00	Mid America Grain 1 Track	
83 01 01	Mid America Grain 1	(ut pit)
83 02 00	Mid America Grain 2	
83 02 01	Mid America Grain 2	(ut pit)
83 03 00	Mid America Grain 3	
83 03 01	Mid America Grain 3	(ut pit)
83 04 00	Frisco Pass	

Page 227

C.E. NO. 12691-IN Engineering & Technology Development 4/92

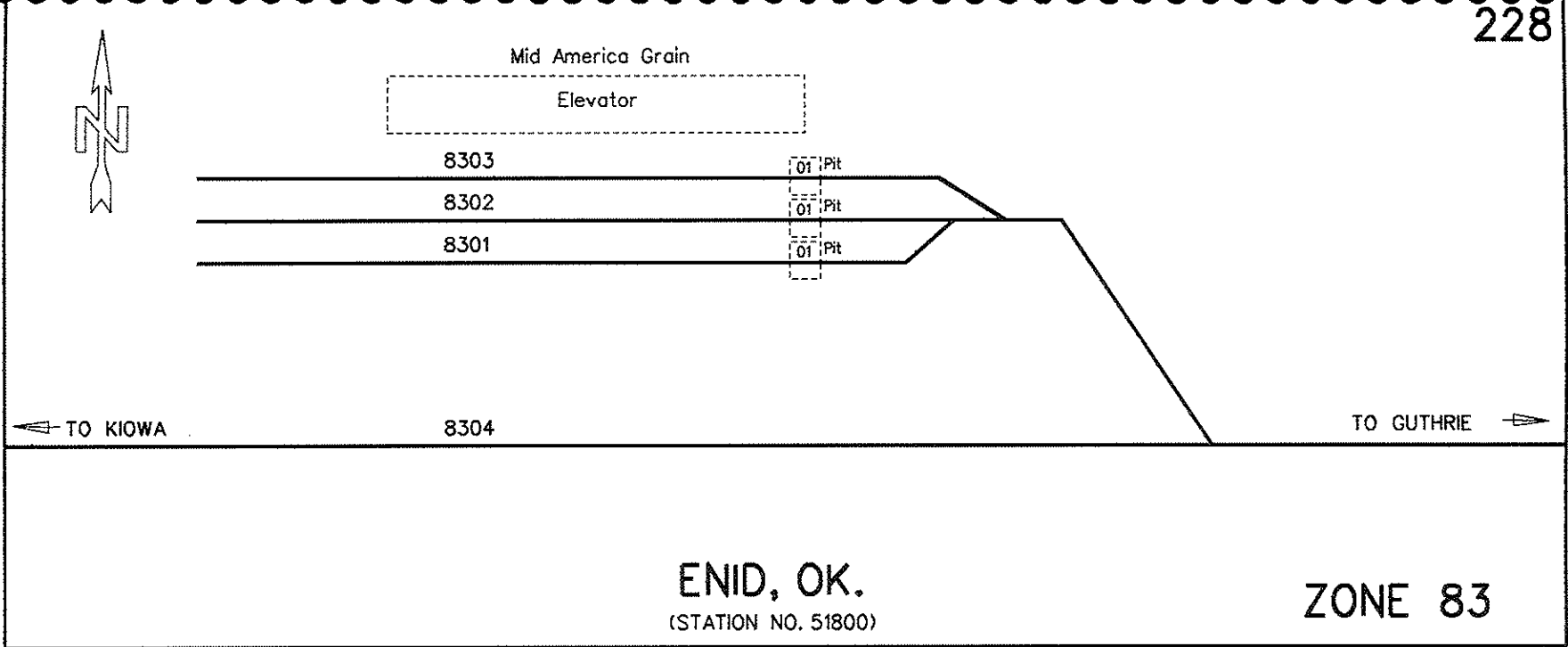

228

228

ENID, OK.
(STATION NO. 51800)

ZONE 83

Zone 83 (Enid 51800) Union Equity Cooperative Exchange

83 05 00	Z Yard No 1
83 06 00	Z Yard No 2
83 07 00	Z Yard Main Track
83 08 00	Z Yard No 3 Track
83 09 00	Z Yard No 4 Track
83 10 00	UE Z Elev 2 Below
83 14 00	AT - Y Elev 3 Below
83 18 00	New UP Interchange

Page 229

C.E.NO. 12691-IN Engineering & Technology Development 4/92

WILLOW ROAD

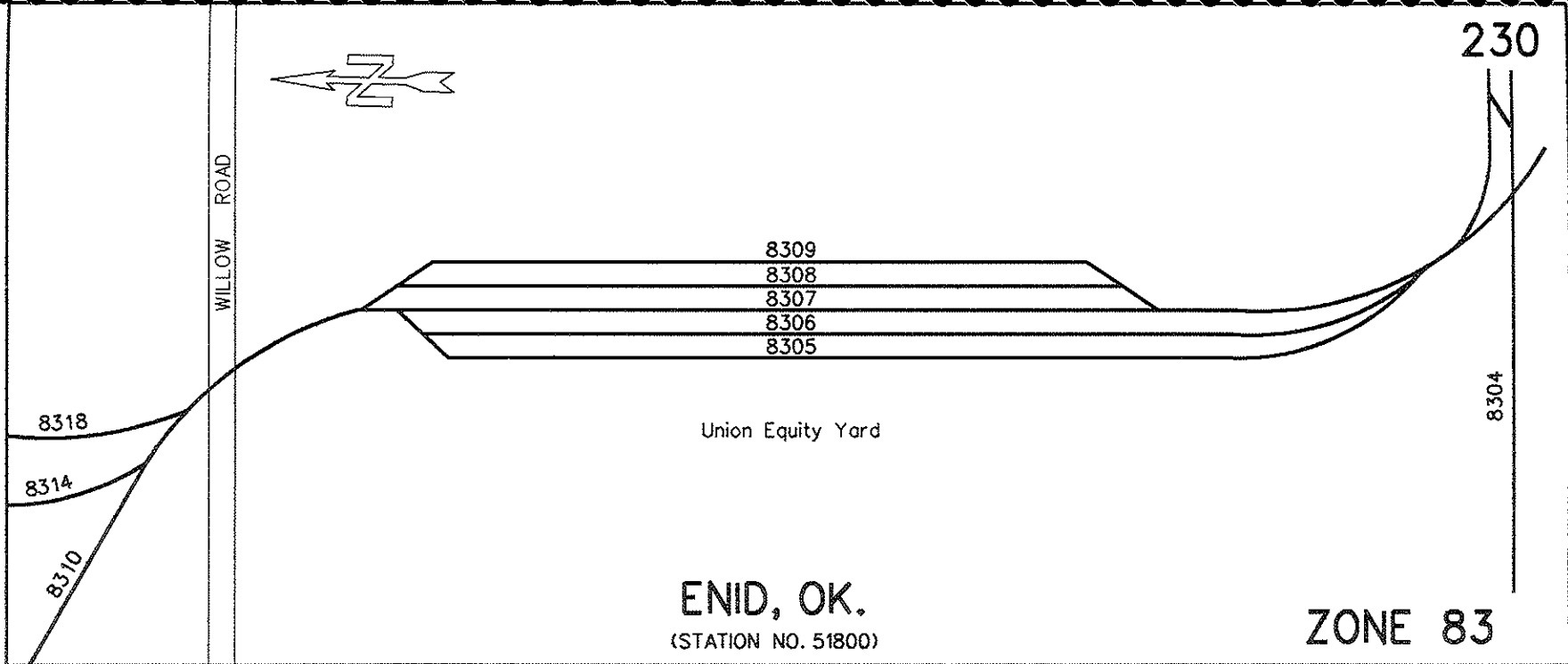
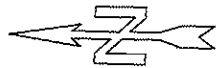

230

ENID, OK.
(STATION NO. 51800)

ZONE 83

Zone 87 (Enid 51800) Enid Subdivision

82 08 00	North Pass
82 99 00	Main Track
83 04 00	Frisco Pass
83 05 00	Z Yard No 1
83 06 00	Z Yard No 2
83 07 00	Z Yard Main Line
83 08 00	Z Yard No 3
83 09 00	Z Yard No 4
87 01 00	Connecting Track
87 02 00	BN Pipe Track
87 03 00	BN 26th Street Pass

Page 231

C.E. NO. 12691-IN Engineering & Technology Development 4/92

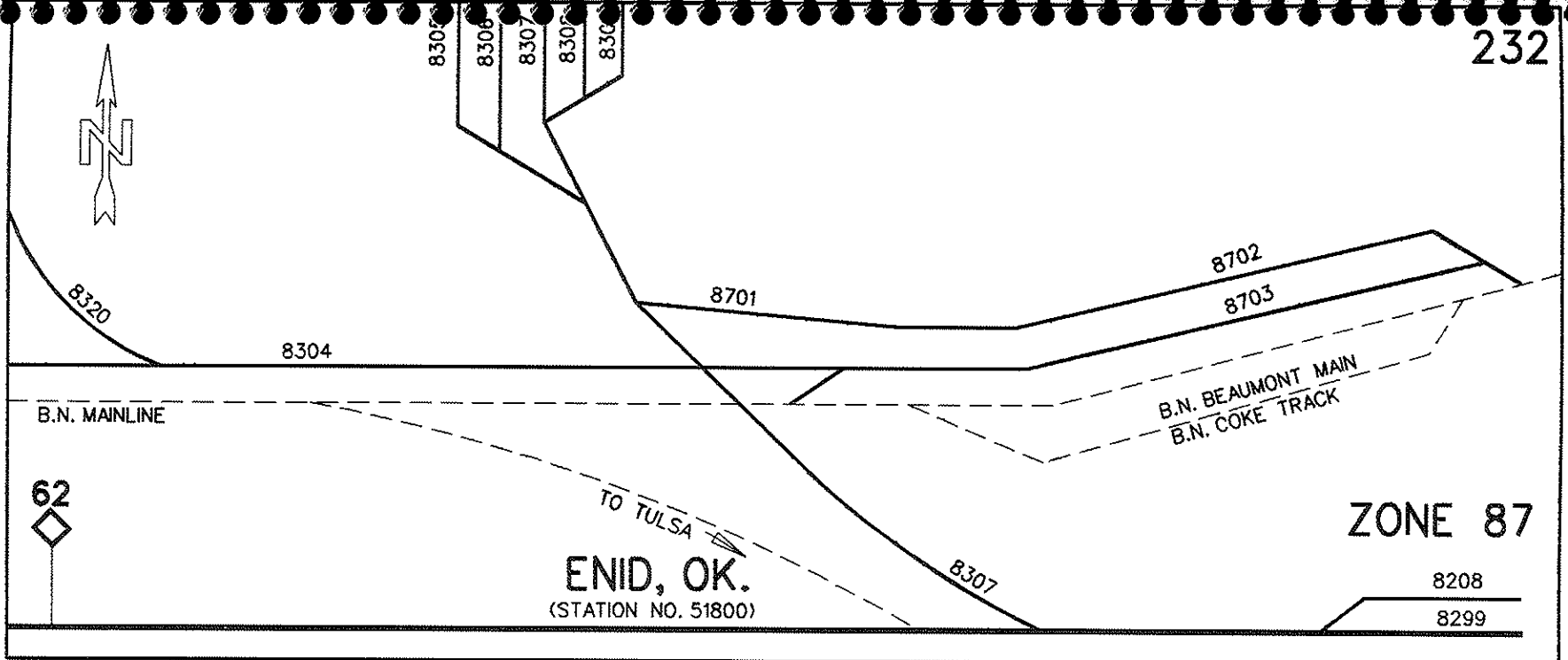

232

232

ZONE 87

8208

8299

Zone 83 (Enid 51800) Union Equity Cooperative Exchange

83 10 00	UE Z Elevator 2 Below	
83 11 00	UE Z Elevator 2 Above	
83 11 01	UE Z Elevator 2 Above	(ut pit)
83 12 00	UE Z Elevator 1 Below Track	
83 13 01	UE Z Elevator 1 Above	(ut pit)
83 14 00	AT-Y Elevator 3 Below	
83 14 01	AT-Y Elevator 3 Below	(ut pit)
83 15 00	AT-Y Elevator 3 Above	
83 16 00	AT-Y Elevator 4 Below	
83 16 01	AT-Y Elevator 4 Below	(ut pit)
83 17 00	New UP Interchange	
83 18 00	New UP Interchange	
83 19 00	AT-Y Elevator 4 Above	

Page 233

C.E. NO. 12691-IN Engineering & Technology Development 4/92

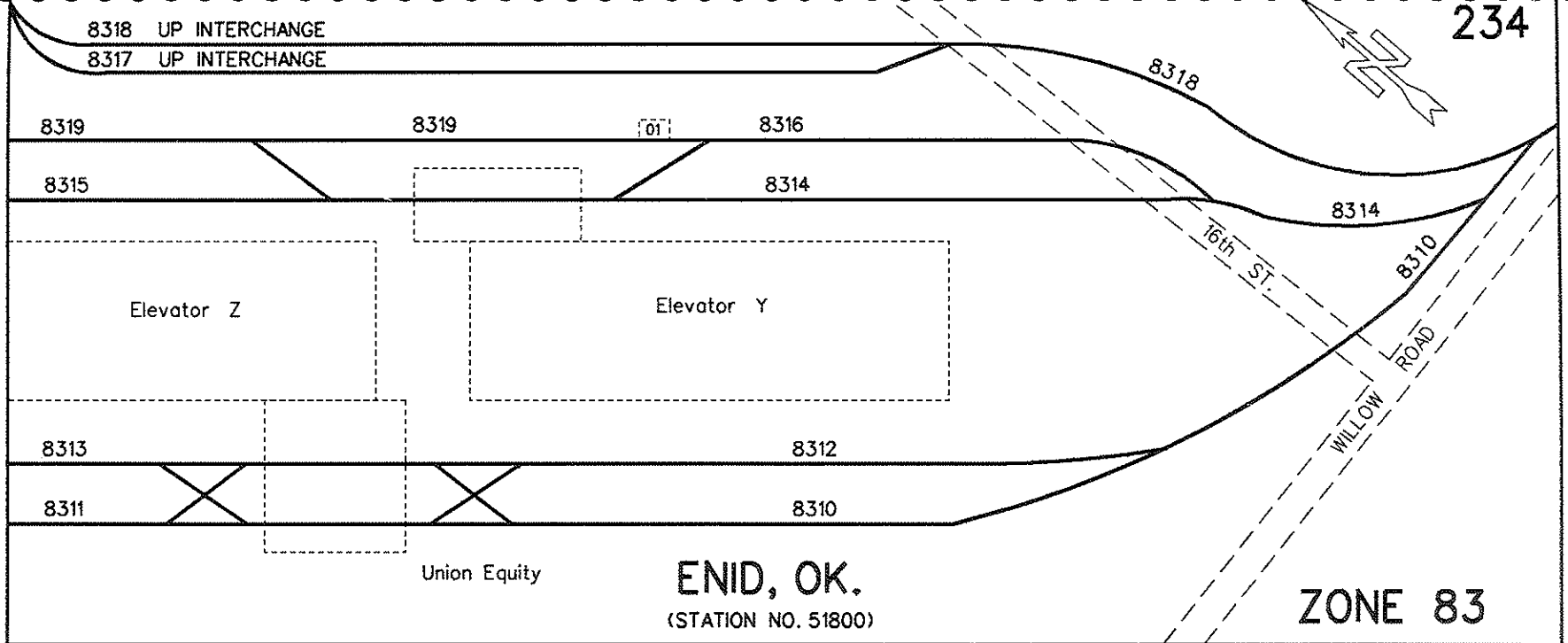

234

Zone 83 (Enid 51800) Continental Grain Co.

83 20 00	Continental Grain Lead	
83 21 00	Continental Grain Track West	
83 21 01	Continental Grain	(pit)
83 22 00	Continental Grain Middle Track	
83 22 01	Continental Grain	(pit)
83 23 00	Continental Grain East Track	
83 23 01	Continental Grain	
83 30 00	Union Equity A & B Lead	

C.E. NO. 12691-IN Engineering & Technology Development 4/92

236

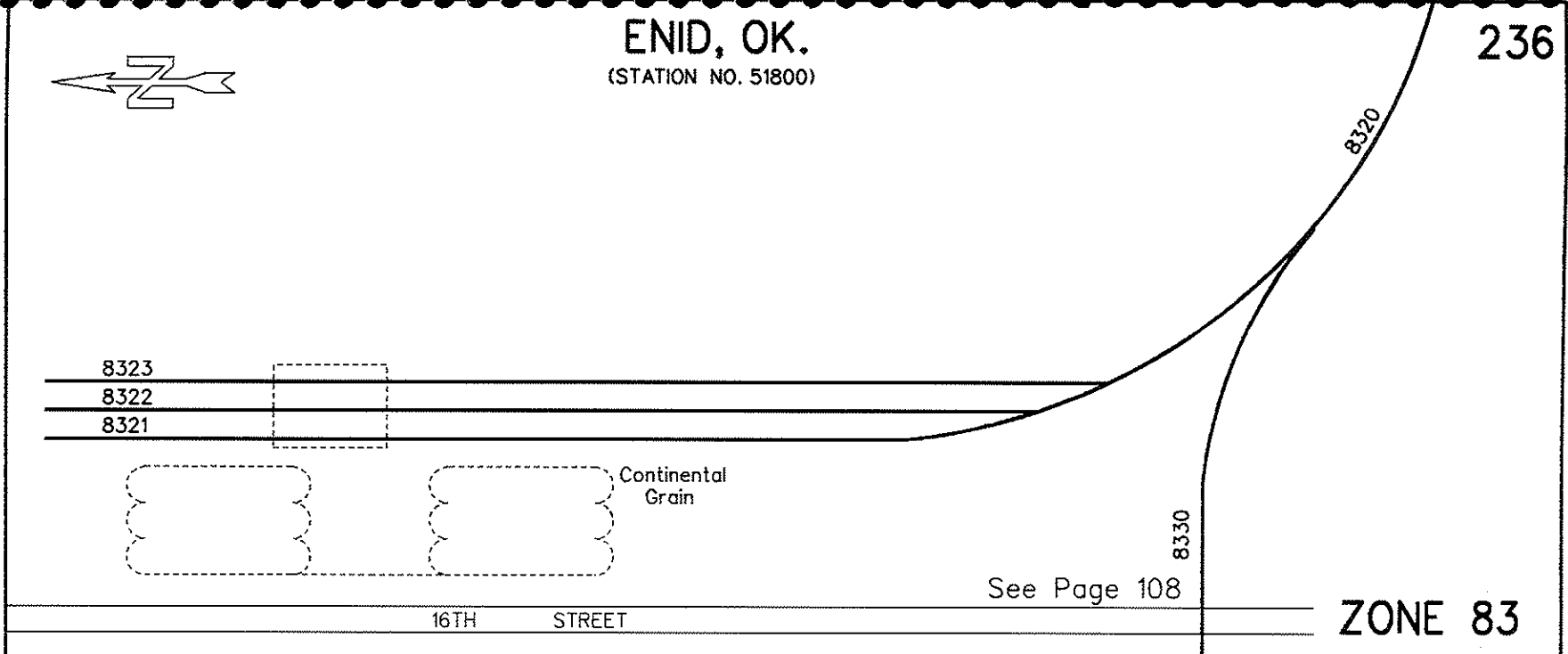

Zone 83 (Enid 51800) Union Equity

83 20 00	Union Equity A & B Lead	
83 33 00	Union Equity B Tail Track	
83 34 00	Union Equity B Tail Track	
83 35 00	Union Equity B Pocket Track	
83 36 00	Union Equity B South Track	
83 36 01	Union Equity B Elevator 6	(pit)
83 37 00	Union Equity B Middle Track	
83 37 01	Union Equity B Elevator 7	
83 38 00	Union Equity B North Track	
83 38 01	Union Equity B Elevator 8	(pit)
83 40 00	Union Equity A Loading Trk	
83 40 01	Union Equity A Elevator	(spout)
83 46 00	Union Equity A Tail Track	
83 47 00	Union Equity A Tail Track	

Page 237

C.E. NO. 12691-IN Engineering & Technology Development 4/92

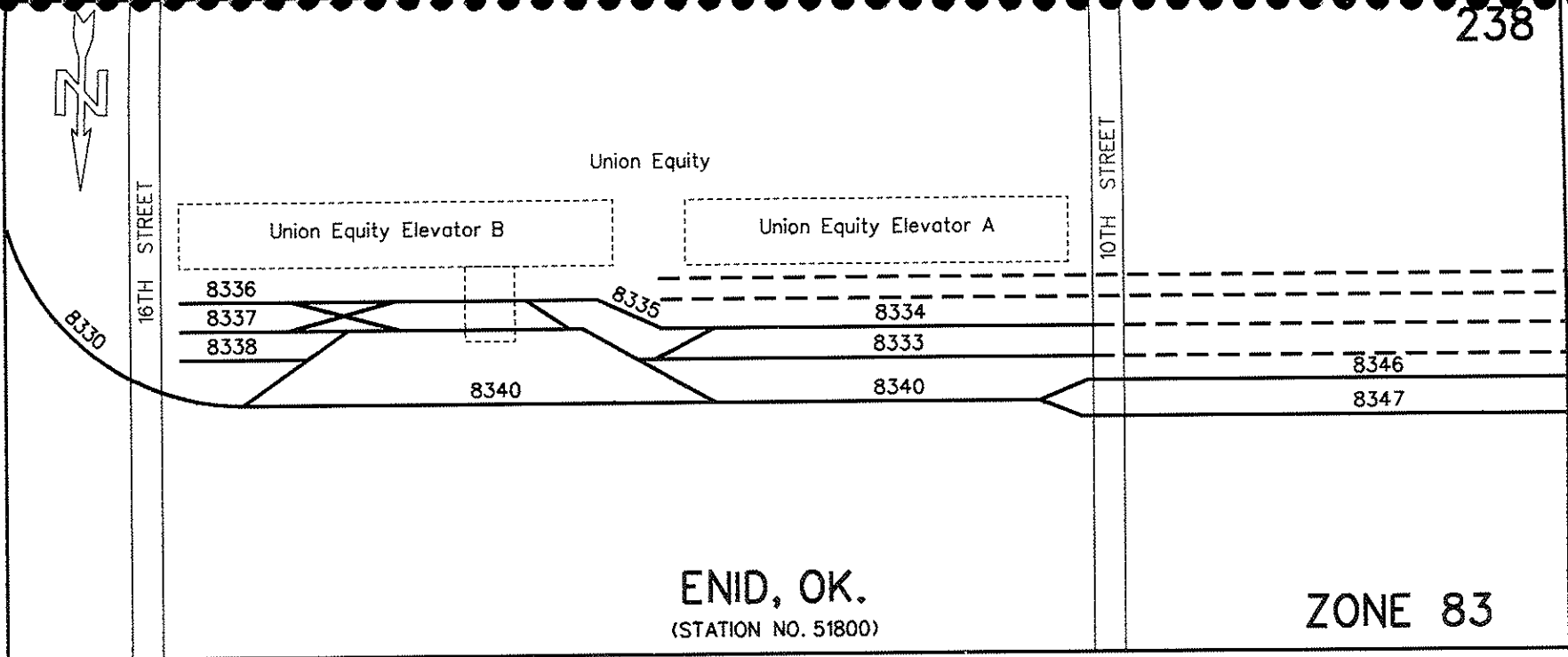

238

238

Zone 84 (Enid 51800) Enid Subdivision

84 02 00	Mid Main		84 08 10	Vacant	(open)
84 03 00	Running Track		84 09 00	Magcobar Track	
84 04 00	Runaround Track		84 09 01	West Side Feed	(door)
84 05 00	General Supply Co		thru 02		
84 05 01	General Supply	(door)	84 09 10	Magcobar	(ramp)
84 05 03	A.M.P.I.	(door)	84 09 11	Magcobar	(door)
thru 04			84 10 00	North Team Sluff Track	
84 06 00	Auto Dock Track		84 11 00	Eason Oil	(door)
84 06 01	Auto Dock	(dock)	84 11 01	Eason Oil	(door)
84 07 00	House Track		thru 02		
84 07 10	Gold Spot Dairy	(door)	84 11 10	Drilling Mud	(door)
thru 11			thru 13		
84 08 00	South Team		84 12 00	Jefferson Street Connection	
84 08 01	Gold Spot Dairy	(door)	84 99 00	Main Track	
thru 03					

Page 239

C.E. NO. 12691-IN Engineering & Technology Development 4/92

240

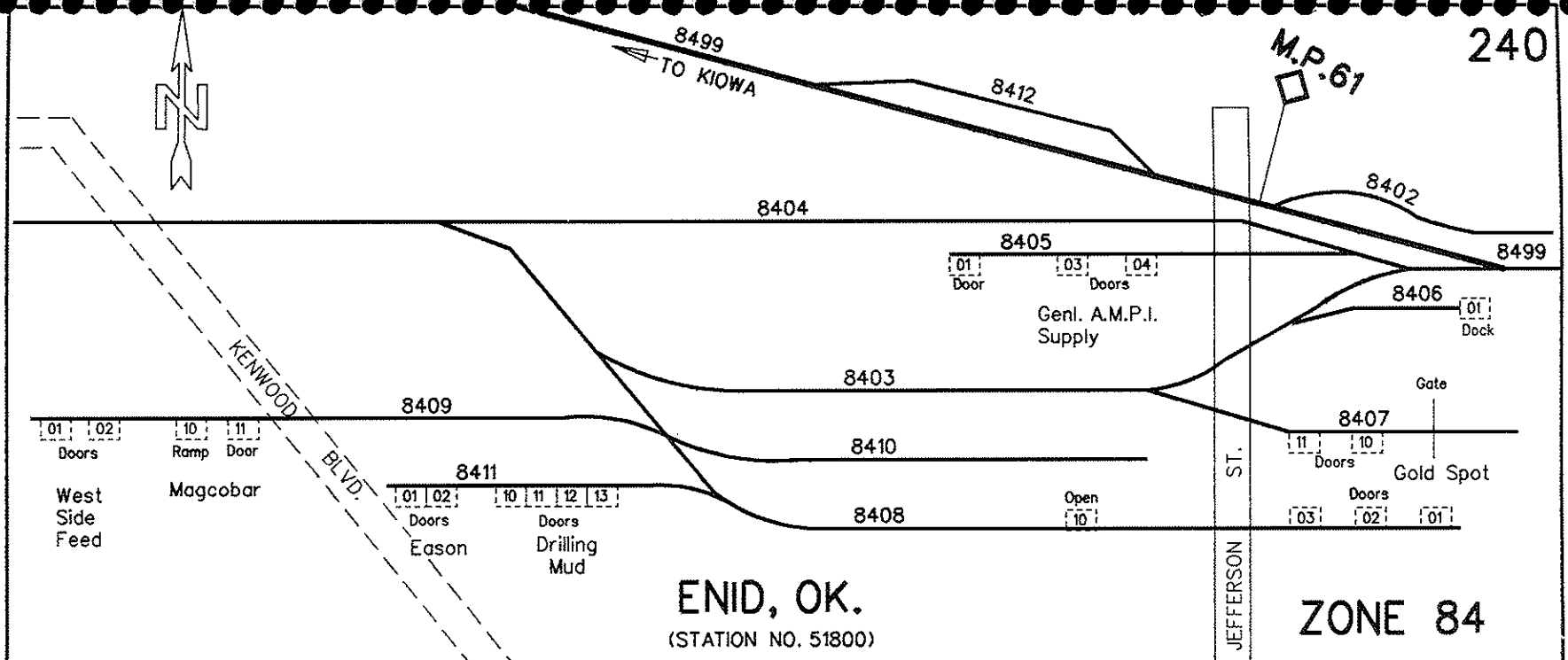

Zone 85 (Enid 51800) Pillsbury Inc.

85 00 00	Pillsbury Company Lead		85 03 02	Pillsburg Inc	(door)
85 01 00	Pillsbury Inc	(Private Track)	thru 04		
85 01 01	Pillsbury Inc		85 03 08	Pillsbury Inc	(feed ldg)
hose)			thru 12		
thru 03			85 03 18	Pillsbury Inc	(df box
85 01 09	Pillsburg Inc	(airslide ldg)	thru 20		
ldg)			85 04 00	Pillsburg Inc Track	
thru 17			85 04 01	Pillsbury Inc	(open)
85 02 00	Pillsbury Inc	(Private Track)	85 04 02	Pillsbury Inc	(crosspot
85 02 01	Pillsbury Inc		thru 04		
thru 03			85 04 08	Pillsbury Inc	(feed ldg)
door)			thru 12		
85 02 09	Pillsbury Inc	(airslide ldg)	85 05 00	Pillsbury Inc	
thru 15			85 05 01	Pillsbury Inc	(pit)
hose)					
85 02 17	Pillsbury Inc	(df box ldg)			
thru 21					
85 03 00	Pillsbury Inc				
85 03 01	Pillsbury Inc	(open)			

Page 241

C.E. NO. 12691-IN Engineering & Technology Development 4/92

242

242

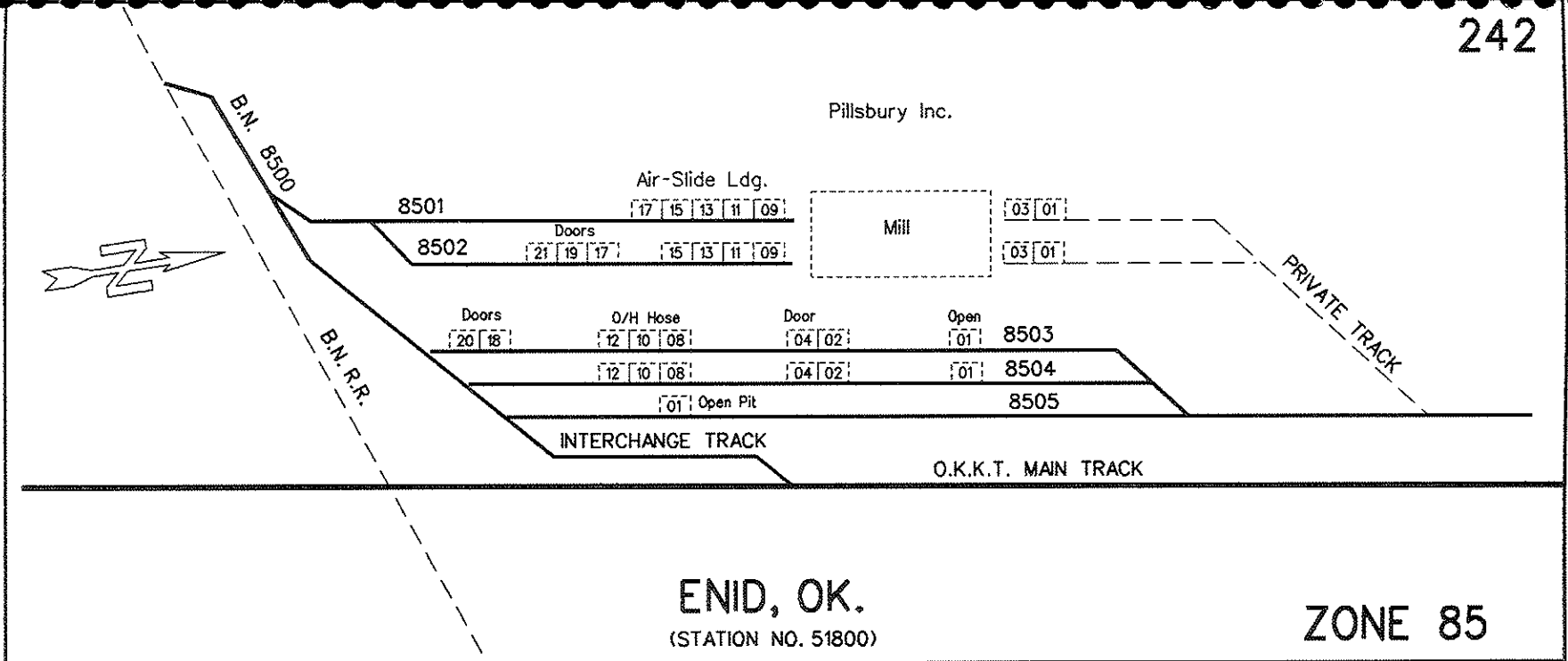

Zone 86 (Enid 51800) Enid Subdivision

86 01 00 Spur Track
86 99 00 Main Track

Page 243

C.E. NO. 12691-IN Engineering & Technology Development 4/92

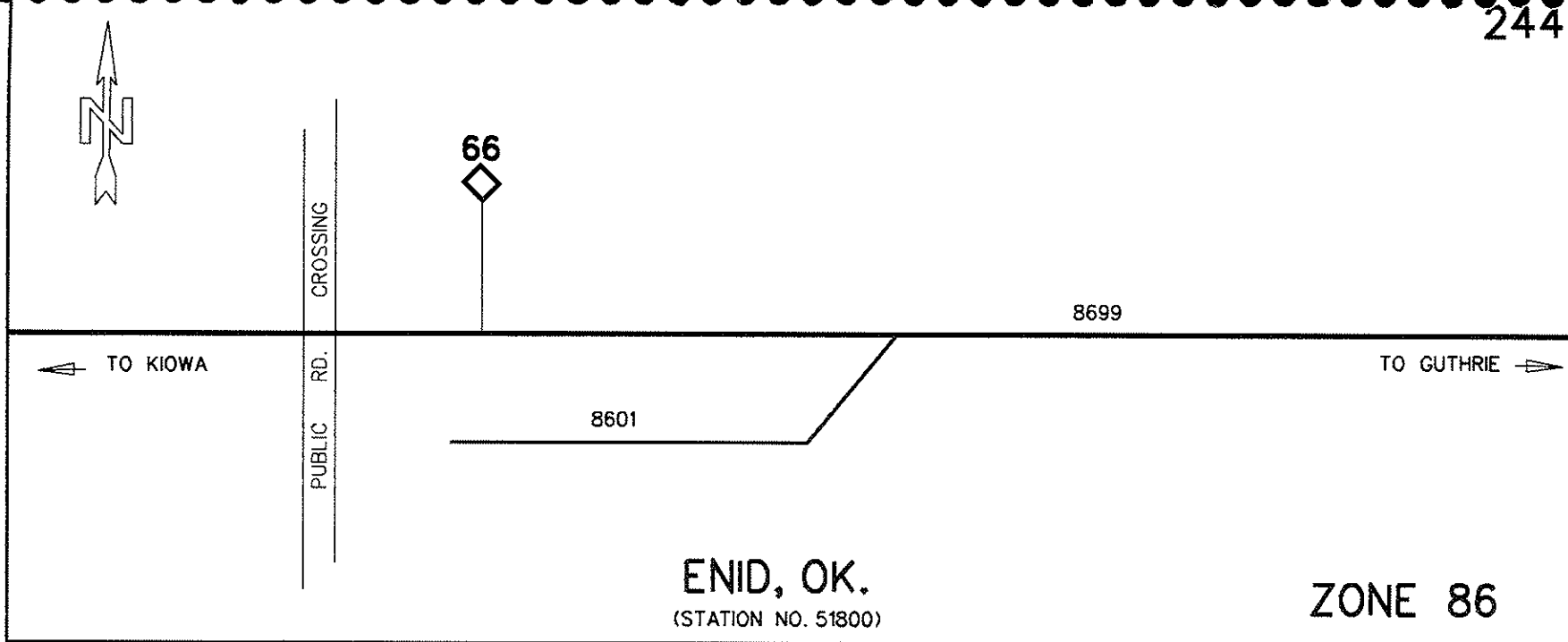

244

244

Zone 72 (Fairmont 51735) Enid Subdivision

72 02 00 Elevator Track Fairmont
72 02 01 Farmers Coop Elevator (spout)
72 99 00 Main Track

C.E. NO. 12691-IN Engineering & Technology Development 4/92

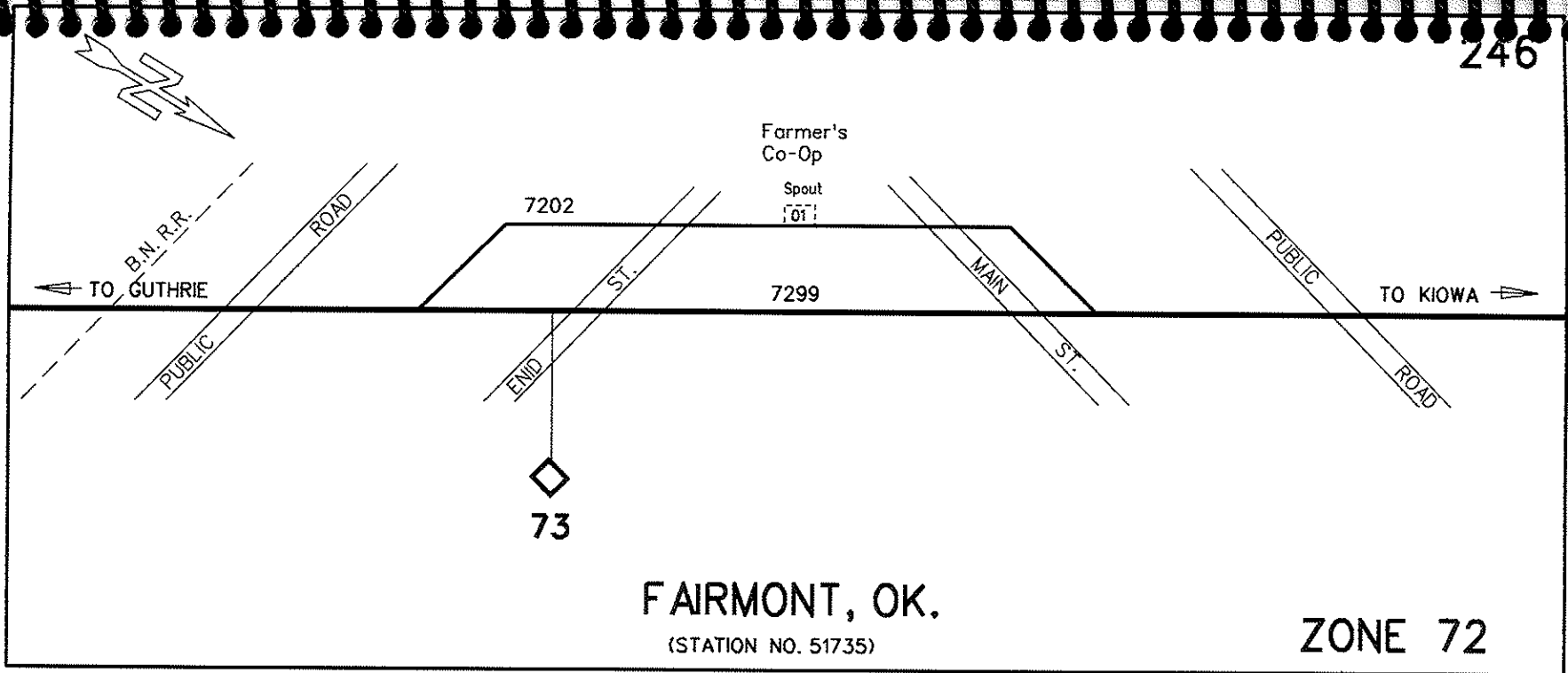

246

246

FAIRMONT, OK.
(STATION NO. 51735)

ZONE 72

Zone 80 (Douglass 51725) Enid Subdivision

80 01 00	Douglass House Track	
80 01 01	Farmers Coop	(fertilizer pit)
80 01 02	Farmers Coop	(dock)
thru 06	Farmers Coop	(door)
80 01 07		
thru 08	Farmers Coop	(spout)
80 02 00	Douglass Siding	
80 02 01		
80 99 00	Main Track	

Page 247

C.E. NO. 12691-IN Engineering & Technology Development 4/92

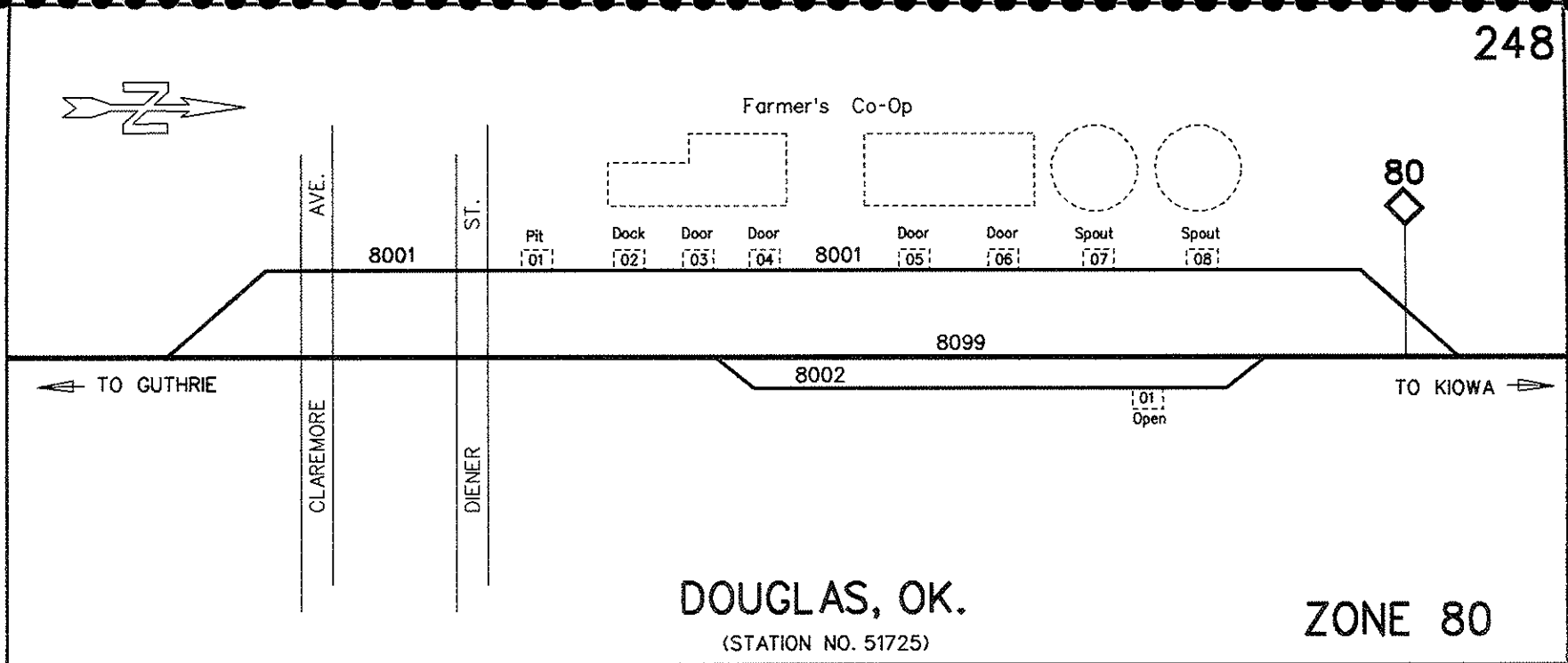

248

Zone 88 (Marshall 51715) Enid Subdivision

88 01 00	Elevator Track	
88 01 01	United Coop	(spout)
88 01 02	United Coop	(door)
thru 03		
88 01 04	United Coop	(spout)
88 01 05	United Coop (dry fertz)	(pit)
88 01 10		(open)
88 02 00	Siding Marshall	
88 03 00	House Track	
88 03 01	United Coop 1 Warehouse	(door)
88 03 02	United Coop	(spout)
88 03 05	United Coop	(dock)
88 03 10	United Coop Warehouse	(door)
88 99 00	Main Track	

Page 249

C.E. NO. 12691-IN Engineering & Technology Development 4/92

250

250

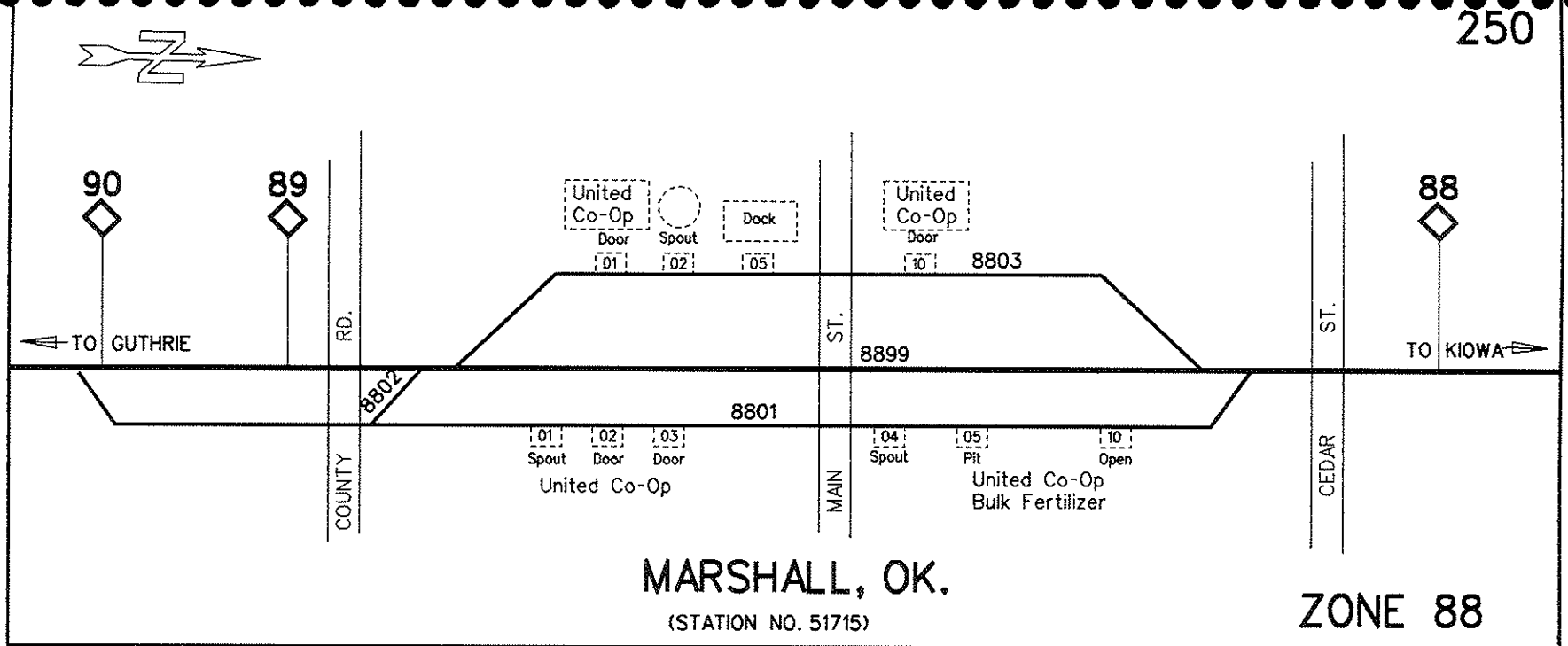

Zone 95 (Lovell 51710) Enid Subdivision

95 01 00	Siding Lovell	
95 01 01		(open)
95 02 00	Elevator Track Lovell	
95 02 01	United Coop	(spout)
95 99 00	Main Track	

Page 251

252

C.E. NO. 12691-IN Engineering & Technology Development 4/92

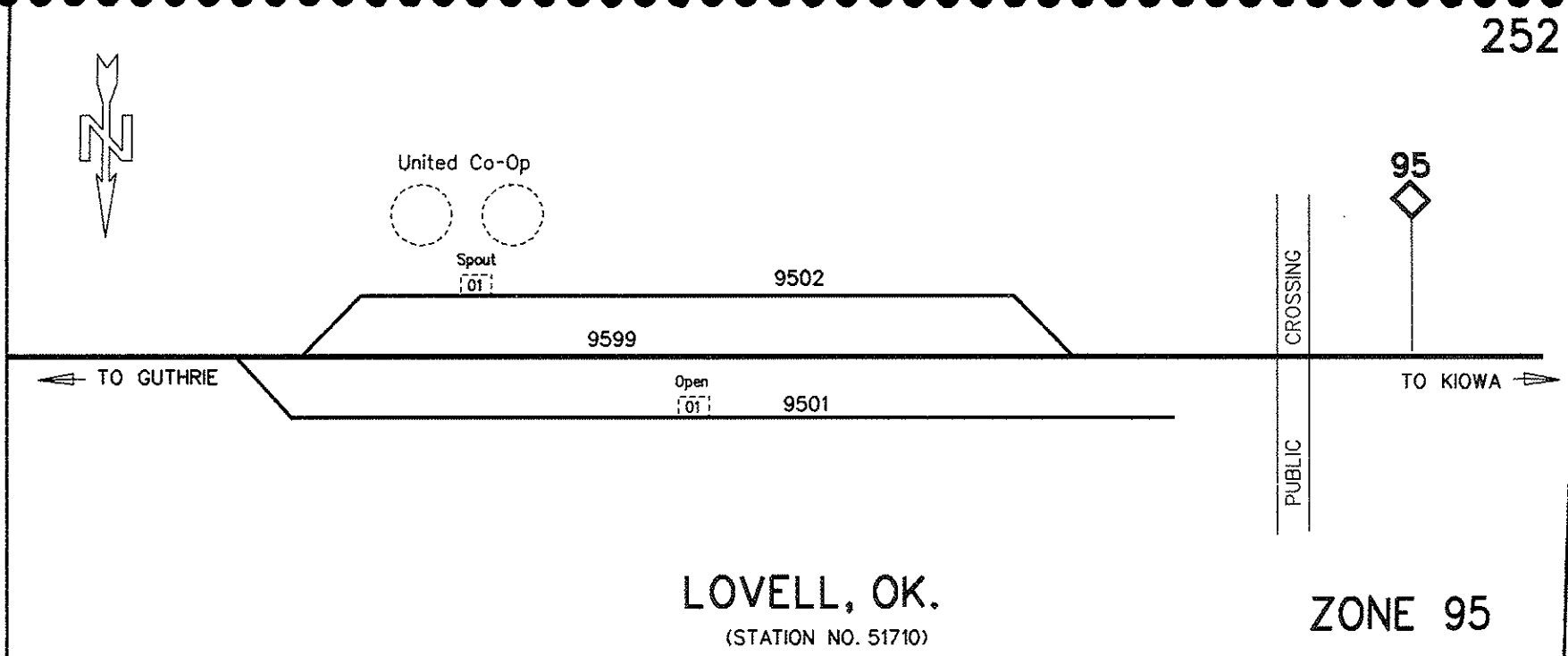

252

Zone 99 (Crescent 51705) Enid Subdivision

99 02 00	Crescent Coop Oil Spur		99 04 13	Crescent Coop	(spout)
99 02 01	Crescent Coop	(spout)	99 05 00	Crescent Coop Fertilizer Track	
99 03 00	Crescent Crossover		99 05 01	Crescent Coop	(pit)
99 04 00	Crescent Coop Elevator Track		99 06 00	Farm Enterprise Elevator Track	
99 04 01	Crescent Coop	(open)	99 06 02	Farm Enterprise	(spout)
99 04 02	Crescent Coop	(dock)	99 06 03	Farm Enterprise	(door)
99 04 10	Crescent Coop	(spout)	99 99 00	Main Track	
99 04 11	Crescent Coop	(door)			
thru 12					

254

C.E. NO. 12691-IN Engineering & Technology Development 4/92

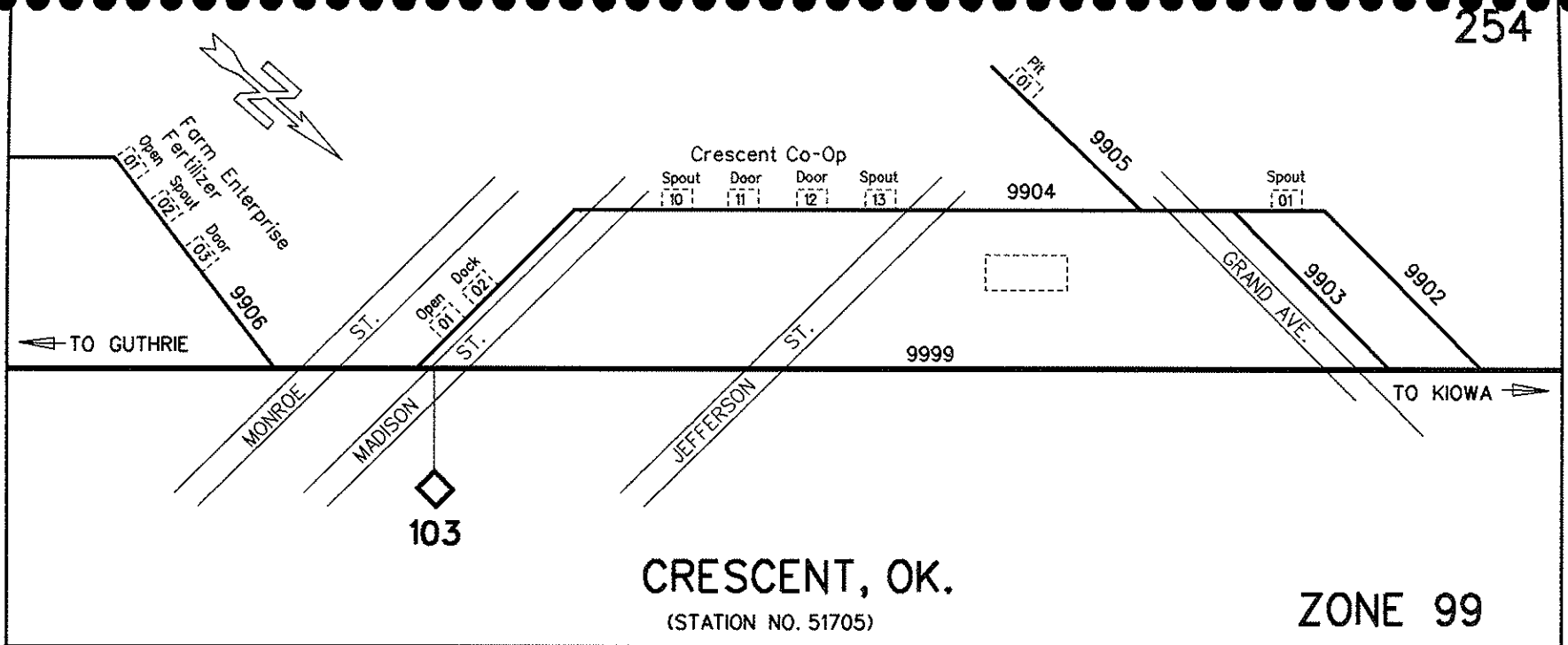

CRESCENT, OK.
(STATION NO. 51705)

ZONE 99