

LIST OF LOADING PAMPHLETS—CLOSED CARS
(Bracketed Date Indicates Latest Issue)

No.	TITLE
2	Wheeled Vehicles (April 1949)
3	Bags - Commodities In (Nov. 1964)
4	Barrels, Drums or Kegs (Nov. 1965)
8	Plywood in Closed Cars (Oct. 1970)
9	Cable & Similar Commodities on Reels (Oct. 1948)
14	Freight - Loading, Bracing & Blocking Of (Dec. 1963)
15	Furniture - Carload (Jan. 1963)*
16	Furniture - Less Carload (Jan. 1963)*
18	Cylindrical Steel Containers (Small) - Commodities & Mixed Loads in Larger Steel Drums (Oct. 1963)*
20	Lumber (Dressed) & Mill Work (Jan. 1963)*
21	Machinery (April 1967)
23	Sheet Steel and Tin Plate (Jan. 1970)
25	Paper & Similar Commodities on Skids (Jan. 1963)*
26	Gypsum, Plasterboard, Lath & Plaster (April 1963)
27	Empty Projectiles, Bombs & Cartridge Cases (Jan. 1963)*
34	Tank Cars Transporting Non-Dangerous Commodities (Nov. 1965)
36	Grain and Other Bulk Commodities (Jan. 1971)
38	Unsaturated Roofing Felt (Nov. 1965)
39	Newsprint (Oct. 1970)
40	Vitrified Clay Sewer Pipe (Jan. 1963)*
41	Dictionary of Standard Terms - Commodities in Closed Cars (Dec. 1961)
42	Glass, Rolled & Plate (Nov. 1965)

O—T DIVISION CIRCULAR

- 42-D General Rules - Covering Loading of Carload Shipments of Commodities in Closed Cars (June 1967)

* - Reprinted

For Copies Address

FREIGHT LOADING AND CONTAINER SECTION
ASSOCIATION OF AMERICAN RAILROADS
59 E. Van Buren Street
Chicago, Ill. 60605

MINIMUM LOADING STANDARDS
FOR
GRAIN
AND
OTHER BULK COMMODITIES
IN
CLOSED CARS AND PROTECTION OF EQUIPMENT



REVISED January 1971
(Cancels GIS No. 537)

Issued by

ASSOCIATION OF AMERICAN RAILROADS

Operations and Maintenance Department

FREIGHT LOADING & CONTAINER SECTION

59 E. Van Buren Street
Chicago, Illinois 60605

Printed in U.S.A.

**MINIMUM LOADING STANDARDS FOR GRAIN
AND
OTHER BULK COMMODITIES IN CLOSED CARS
AND
PROTECTION OF EQUIPMENT**

GENERAL RULES

The "General Rules," as contained in Circular No. 42-D, or supplements thereto, issued by the Operating-Transportation Division, Association of American Railroads, which have been formulated for purpose of providing safe methods of loading in closed cars, must be observed.

For ready reference the salient provisions of General Rules 1, 3 and 5, principally applicable to the loading of bulk grain, are repeated below:

A—SELECTION OF CAR

A-1 General Rule 1A. Inspection and Selection of Cars

"Cars must be inspected either before they are placed for loading or at loading point to see that they are in suitable condition to carry loads safely to destination."

A-2 General Rule 3A. Maximum Load Weight

"The weight of load on a car must not exceed the load limit stenciled on car." (See Illustration No. 1)

A-3 General Rule 5A. Loading, Blocking and Bracing

"All lading must be so secured that it will not come in contact with side doors . . ."

A-4 Clean Car Before Coopering

The residue or refuse from previous loading must be removed and the car swept clean. No odors should be present in car which could damage lading, such as from oil, grease, tar, acids, poisons, hides, cement, etc.

A-5 Linings

Cover broken and defective lining pieces with boards. Do not use paper or grain doors for this purpose. (See Illustration No. 2)

A-6 If grain vents at floor are obstructed they should be reopened. Do not remove any permanent lining. (See Illustration No. 8)

A-7 Look for cracks or defects in car floor and cooper effectively:

- (a) At ends of floor boards.
- (b) At ends of car between last board and end lining. (See Illustration No. 2)
- (c) Between floor boards. Calk or cover with cooping paper. If separations are too wide to be calked, reject car.
- (d) Cover defects and small holes in car floor with thin metal pieces, taking extreme care that all edges are secured with small nails. (See Illustration No. 2)

DO NOT USE GRAIN DOORS OR BOARDS TO COVER HOLES IN CAR FLOOR UNDER ANY CIRCUMSTANCES AS SUCH PROJECTIONS CONSTITUTE A HAZARD TO POWER SCOOP OPERATORS WHEN UNLOADING CAR.

B—INSTALLATION OF THE REINFORCED PAPER GRAIN DOORS

Each manufacturer of reinforced paper grain doors has issued detailed instructions for the proper installation of grain doors and these directions should be closely followed. If this is done, grain-tight installation can be properly made by one man. Proper installation is necessary in all instances.

B-1 Paper grain doors will be reinforced with a minimum of twelve steel straps. *These grain doors are intended for single trip use.*

B-2 Do not nail boards to doorpost or car lining to provide a nailing surface for application of paper grain doors.

B-3 Tight installation requires correct tension nailing of steel straps and proper application of extension or retention straps. Illustration No. 3 describes proper tension nailing. There will be a minimum of two double-headed nails [1¾" x 10¼ gage (8d wire size)] each end of each strap. Do not use larger nails.

B-4 Third, fifth, and seventh or third, sixth and ninth straps (depending on manufacturers arrangement) should extend 20" longer than other straps to avoid all anchorage points in one carpost location. When grain doors are not so equipped, extension or retention straps shall be spliced to the proper grain door straps by either inserting prong supplied strap to grain door strap and bending prongs down with a hammer and/or tension nailing double-headed nails through extension strap and grain door strap and into the doorposts. These straps will then be tension nailed to carpost back of doorpost with double-headed nails. (See Illustration No. 5)

B-5 Minimum 1" x 6" bottom pry board must be applied directly to the doorpost. (See Illustration No. 5). Be sure to apply a 12" length of calking paper on top of pry board at each end to seal small aperture between paper grain door and doorpost. This board must be on outside of barricade in order to facilitate opening car doors with pry bars.

Note: It is recommended that the pry board be used whenever paper grain doors are used for cooping cars to be loaded with any bulk commodity.

B-6 Illustration No. 5 shows a detailed application of minimum 1" x 6" top pry board applied inside of barricade. Since the board must support weight of grain sampler, it is essential to select board of good material and adequately nailed through paper door and then into the doorpost.

B-7 Use cross-tie assemblies in accordance with manufacturer's recommendations in cars with doorway openings more than 6 ft. in width.

- (1) Use single cross-tie assembly in cars with doorway openings 7' or 8' in width (See Illustration No. 6).
- (2) Use double cross-tie assembly in cars with doorway openings 9' or 10' in width (See Illustration No. 7).

Match the style of brace with that manufacturer's instructions.

C—PREPARATION OF DOORPOSTS AND BOTTOM GRAIN DOORS FOR APPLICATION OF WOOD GRAIN DOORS

C-1 When wood grain doors are to be used, apply calking paper on each doorpost to the coopered height. Calking paper should also be tacked to the bottom edge of the first wood grain door. This will insure against leakage under the door should the frame of the car or grain door edge be uneven. (See Illustration No. 8)

D—INSTALLATION OF WOOD GRAIN DOORS

D-1 Select good sound doors free from protruding nails. The grain doors must be fabricated in accord with the following specifications for cars having 6 foot wide doors:

Grain doors shall be 7' long, 20" and 10" wide.

Note: A length of 7'6" instead of 7', and widths of 18" and 8" instead of widths of 20" and 10" are acceptable as alternate dimensions.

D-2 The bottom door should be firmly placed against the doorposts and car floor, secured to doorposts by two 12d nails at each end.

If the doorposts have excessive splits, holes, etc., nail only into sound wood. **UNDER NO CIRCUMSTANCES USE SPIKES IN NAILING GRAIN DOORS** (See Illustration No. 9).

D-3 Succeeding courses of grain doors should be applied tightly against lower door and doorposts. Fill cracks at each end of first and second, second and third, and third and fourth doors with calking paper (See Illustration No. 9).

D-4 In cars with doorway openings 6 ft. wide,

- (a) 20" reinforcing doors should be applied tightly over joints of the first and second and third grain doors (See Illustration No. 9).
- (b) Backup paper, used in lieu of the two 20" reinforcing doors, should be made from two thicknesses of sulphate paper each having a minimum basis weight of 30 pounds. These are combined with a waterproofing compound reinforced with fibre threads on 1" centers, lengthwise and crosswise on the sheet and having a basis weight of 90 pounds. Resulting backup paper would have a basis weight of 30-90-30. (See Illustration No. 10).

D-5 It will be noted that the use of wood grain doors is limited to cars having doors with six foot openings. For cars having wider openings refer to Section B-7.

E—LOADING, INCLUDING LEVELING OR TRIMMING OF COMMODITY IN CAR

E-1 Height of Cooperage

Cooperage should be applied higher than the commodity in the car

when level, allowing a minimum of six inches between top of load and top of cooperage through the use of splash panels or additional cooperage.

E-2 Trimming Commodities in Cars

To prevent spillage over doors by shifting of the load during transit and to insure proper distribution of weight in the car, it is required to trim (level) the commodity and determine whether height of commodity requires additional cooperage.

E-3 Inspection of Car After Loading

After car is loaded it should be inspected to see that it is commodity tight and that doors have been properly installed. If inspection develops any defects in car or in doors, which cannot be repaired under load, car should *not* be allowed to go forward.

E-4 Replacement of Top Cooperage After Sampling

When it is necessary to remove top cooperage for facility of entry by sampler for inspection, the cooperage must be replaced prior to closing the car door in order to prevent loss of commodity.

F—UNLOADING OF CAR

F-1 Protection of Equipment

Do not mutilate car doors or sheathing of cars. Do not jab the point of a crowbar into the doors or outside sheathing of cars. Many cars have to be sent to repair yards and rip tracks because of such mutilation.

F-2 Methods for Releasing Commodity From Cars

(a) **Cars Coopered with Paper Doors.** The door may be ruptured by using a hatchet to cut the straps near the doorposts. After unloading, nails in floor flaps should be removed with a pry bar or claw hammer (See Illustration Nos. 12 & 13).

After unloading remove grain door from opposite side of car. If these double-headed nails and straps are not removed other freight loaded into these cars might readily be damaged.

Note: Safety Measure. After the car has been emptied the ends of steel straps remaining on the doorposts must be removed by drawing the double-headed nails with a claw hammer or pry bar. Allowing these straps to remain on doorposts is a constant source of possible injury to elevator workmen and trainmen.

(b) **Cars Cooped with Wood Doors.** To readily release grain from cars and to prevent damage to wood grain doors, a properly shaped bar should be used (See Illustration No. 11). Apply the leverage to best advantage following the steps outlined below:

(1) Remove the top door first, then the next door from the top, progressing, in order, to bottom door being removed last.

(2) Loosen both ends of each grain door, starting at the top. Before attempting to pry one end of any grain door upward, be sure to loosen thoroughly both ends of the door from the doorposts. It is of the utmost importance to follow the above instructions. (See Illustrations Nos. 14, 15 and 16).

SHIPPERS OR CONSIGNEES MUST NOT DAMAGE, DESTROY APPROPRIATE OR USE A CARRIER'S WOODEN GRAIN DOORS, GRAIN DOOR LUMBER OR OTHER COOPERAGE MATERIAL FOR ANY PURPOSE OTHER THAN FOR WHICH INTENDED.

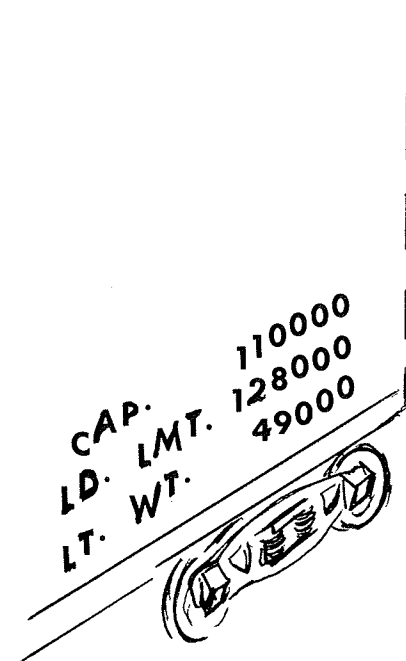

ILLUSTRATION NO. 1

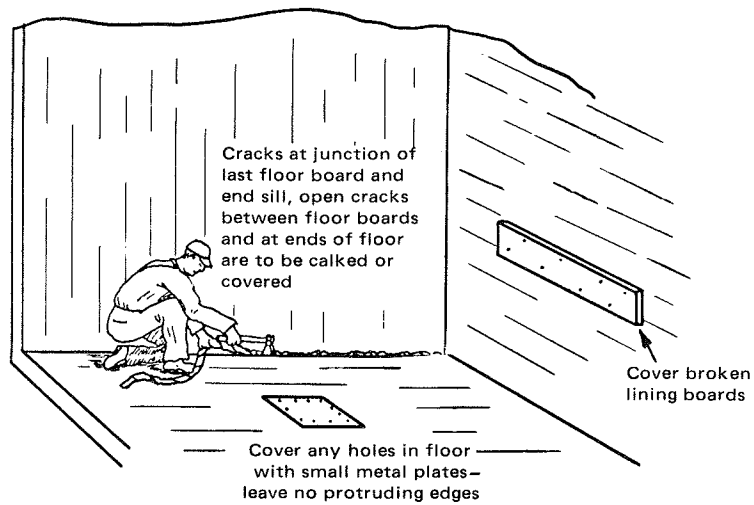

ILLUSTRATION NO. 2
PREPARATION OF CARS

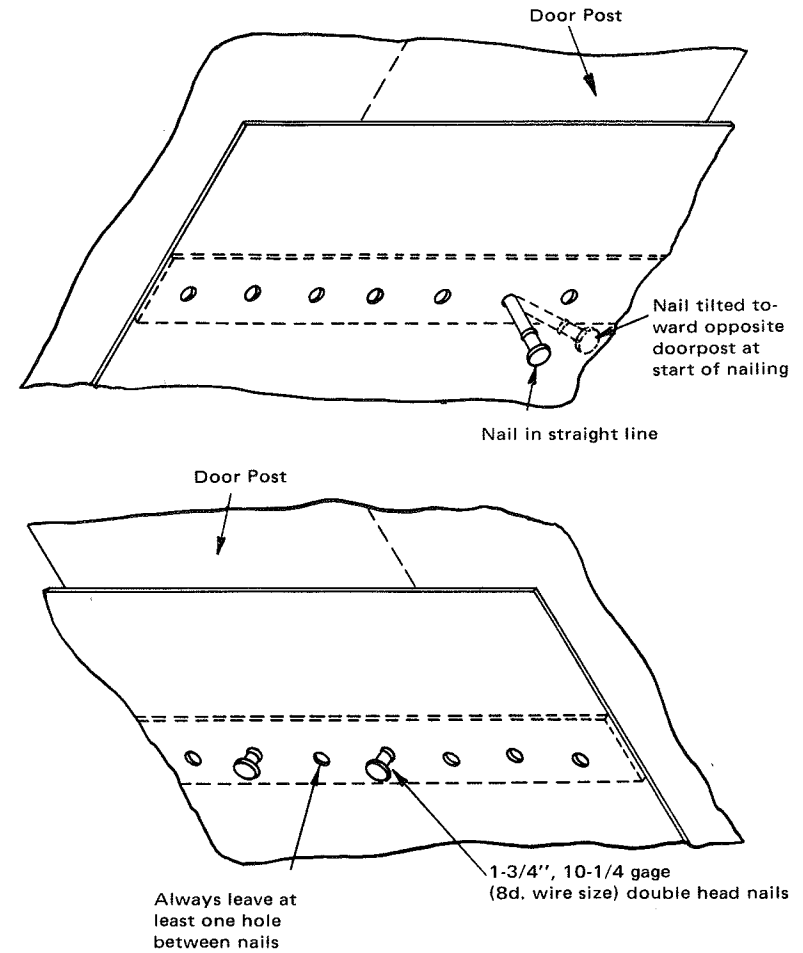

ILLUSTRATION NO. 3
TENSION NAILING PROCEDURE

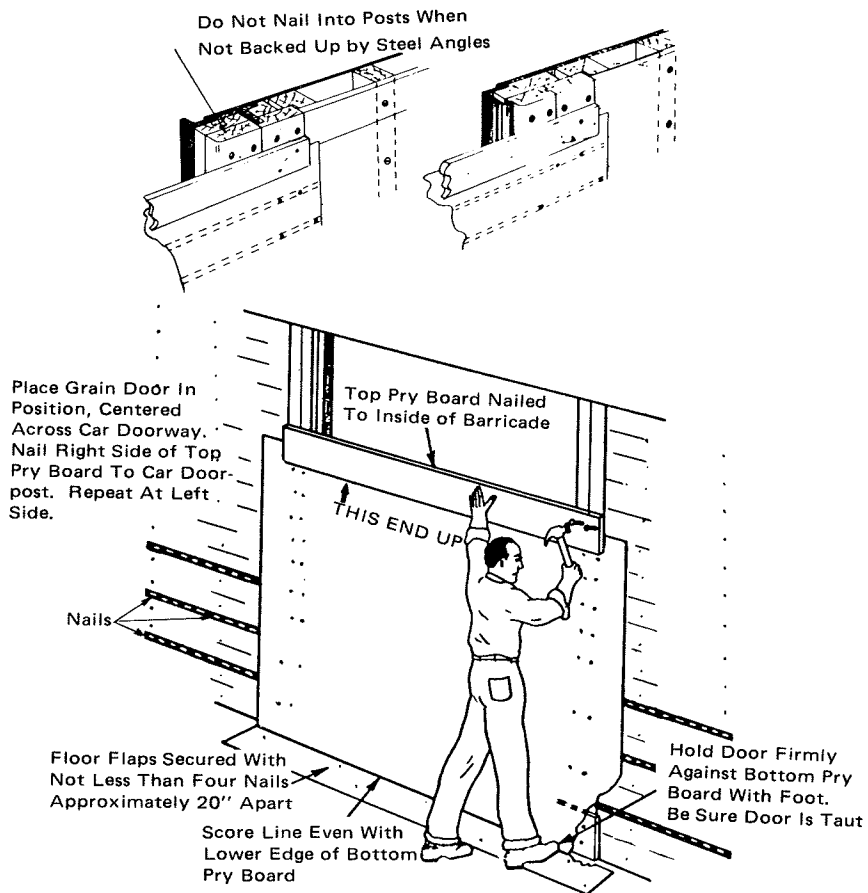

ILLUSTRATION NO. 4
 INSTALLING REINFORCED PAPER GRAIN DOORS
 (Detail Showing Proper Nailing Locations)
 (See Paragraphs B-1 Through B-5)

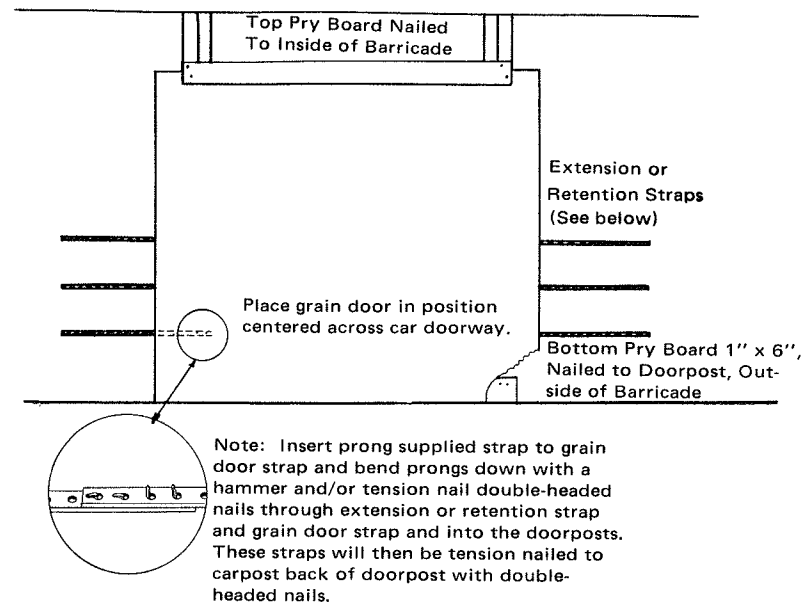

ILLUSTRATION NO. 5
 CORRECT APPLICATION OF EXTENSION OR RETENTION STRAPS

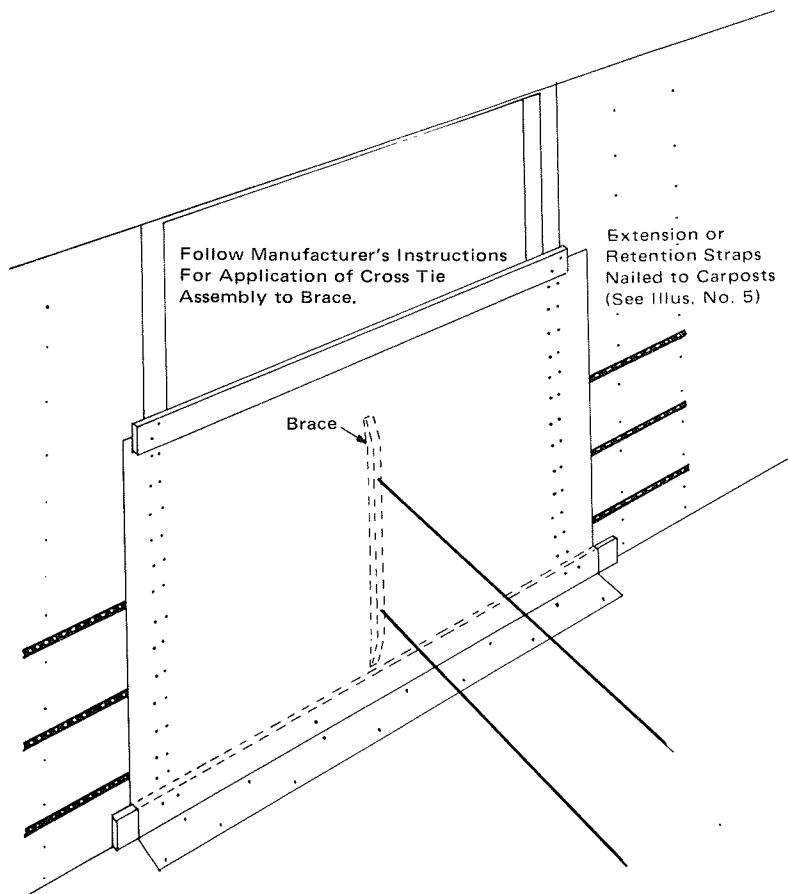

ILLUSTRATION NO. 6
SINGLE CROSS TIE ASSEMBLY
For 7' and 8' Doors

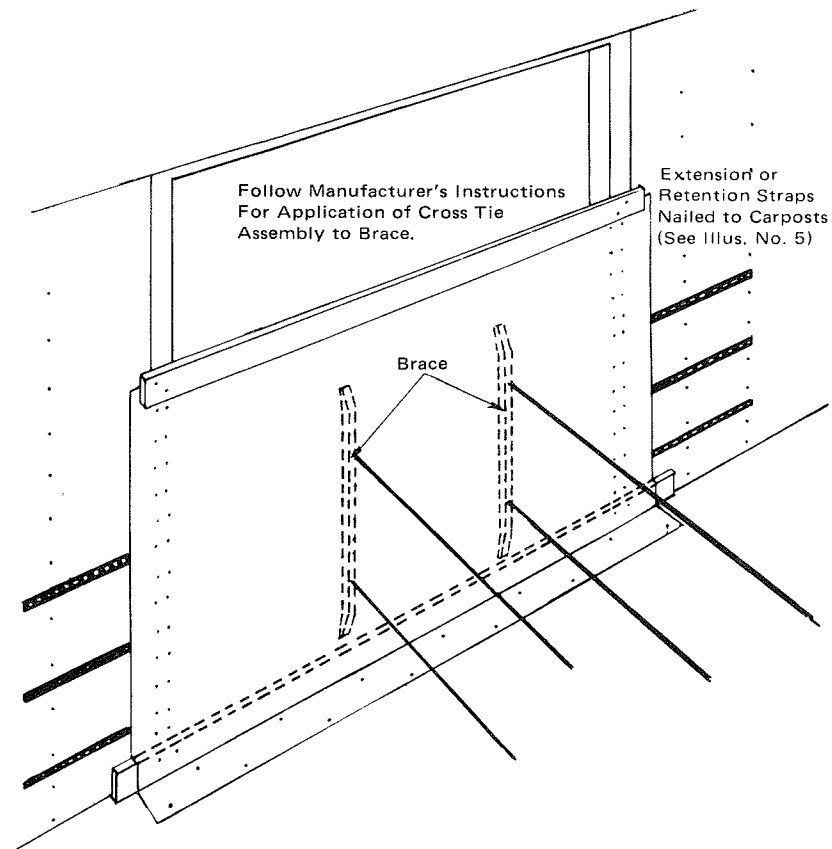
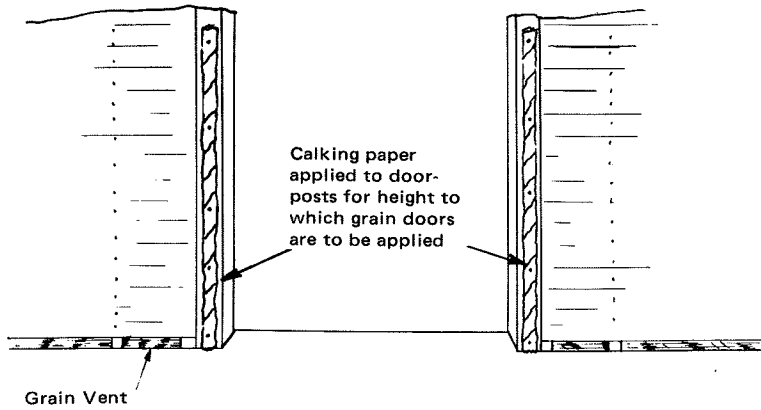
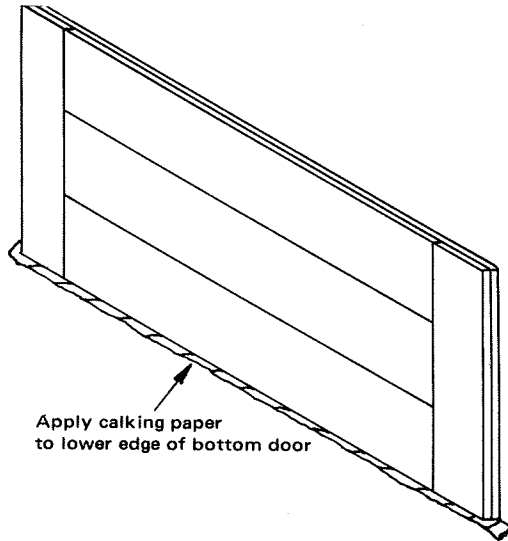

ILLUSTRATION NO. 7
DOUBLE CROSS TIE ASSEMBLY
For 9' and 10' Doors



SKETCH 1



SKETCH 2

ILLUSTRATION NO. 8
APPLICATION OF CALKING PAPER FOR WOOD GRAIN DOORS
(See Illustration No. 9)

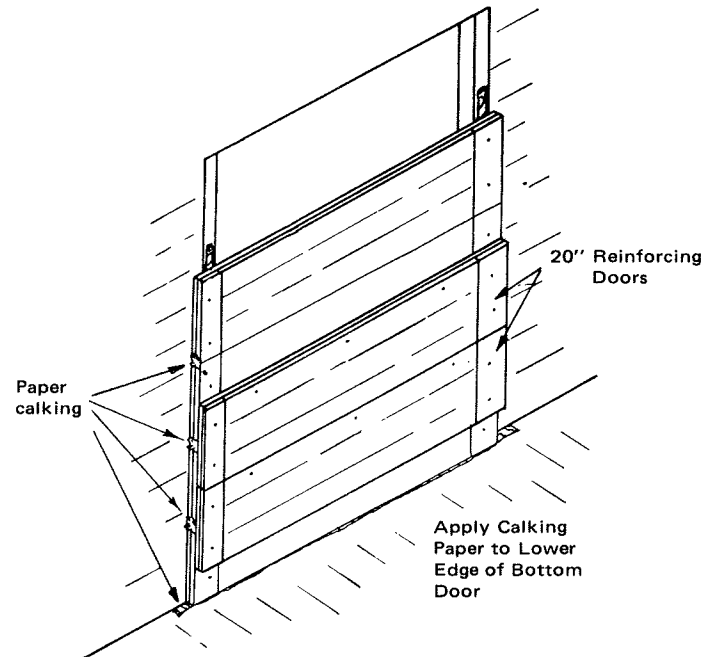
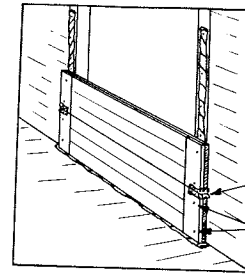

ILLUSTRATION NO. 9
WOOD GRAIN DOOR REINFORCED WITH 20" REINFORCED DOORS

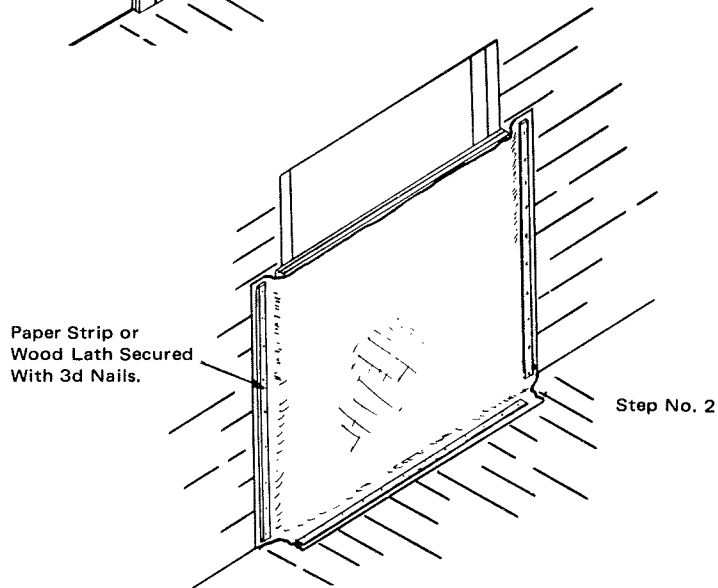
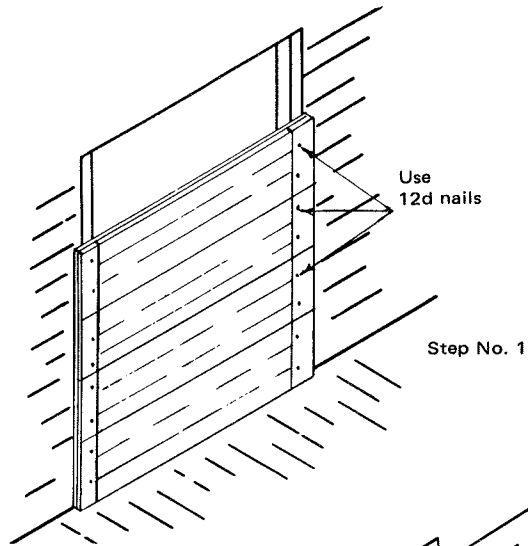
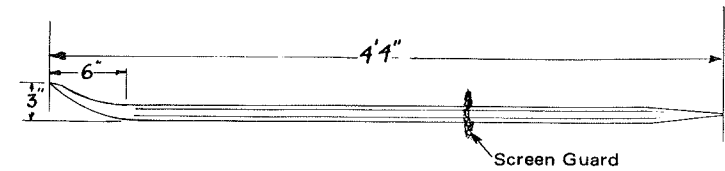
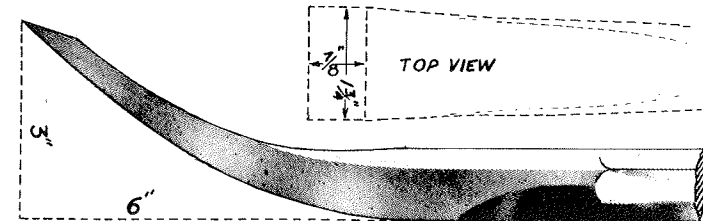

ILLUSTRATION NO. 10
INSTALLATION OF WOOD GRAIN DOOR USING BACKUP PAPER



SKETCH 1



SKETCH 2

Metal - Octagon tool steel
 Diameter - 1-1/4 inches
 Length - 4 ft. 4 inches. The
 length of the bar may be modified,
 if need be, to fit conditions, due to
 lack of sufficient space at any un-
 loading hopper.
 Weight - 17 1/2 lbs.

Screen Guard - Guard (Sketch 1), of
 sufficient size to prevent bar from passing
 between grate rods (screen), over grain
 unloading hoppers.
 Foot - Acr (or throw), 3 inches.
 Fulcrum - Variable from point of
 blade to extreme heel which is 6 inches.
 Blade - Width 1-3/4 to 2 inches.

ILLUSTRATION NO. 11
BAR FOR RELEASING GRAIN DOORS

Note: After unloading remove paper grain doors from both doors of car.

Rupture the grain door adjacent to one doorpost by delivering sharp blows to cut the strap.

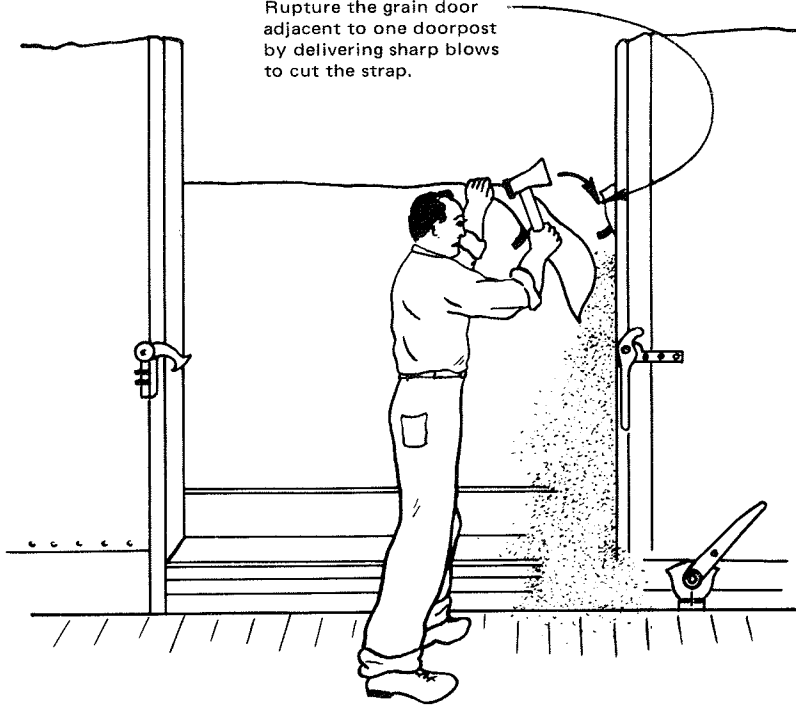
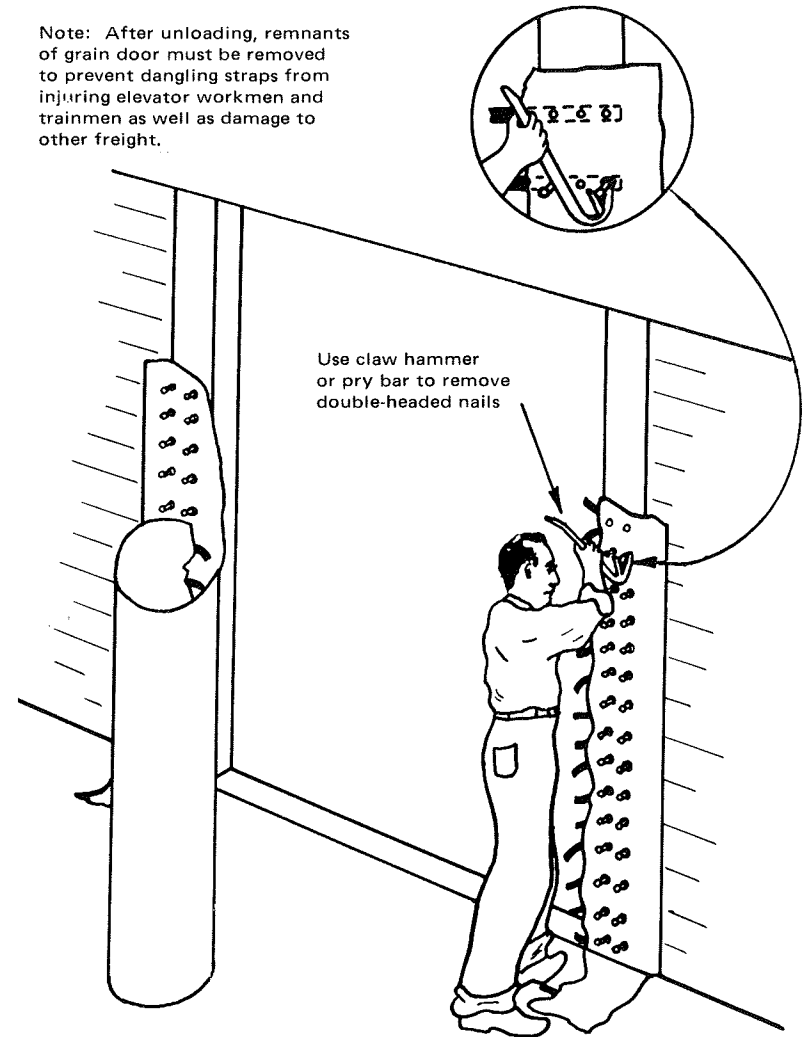

ILLUSTRATION NO. 12
OPEN STEEL STRAP REINFORCED GRAIN DOOR

Note: After unloading, remnants of grain door must be removed to prevent dangling straps from injuring elevator workmen and trainmen as well as damage to other freight.



Use claw hammer or pry bar to remove double-headed nails

ILLUSTRATION NO. 13
REMOVING NAILS FROM DOORPOSTS

ILLUSTRATION NO. 14
RELEASING GRAIN FROM CARS EQUIPPED
WITH WOOD DOORS



ENDS MUST BE WELL LOOSENED FROM DOORPOSTS
BEFORE PRYING ANY DOOR UPWARD

ILLUSTRATION NO. 15
RELEASING GRAIN FROM CARS EQUIPPED
WITH WOOD DOORS



AFTER ENDS ARE THOROUGHLY LOOSENED, PRY DOOR
UPWARD, FIRST ONE END, THEN OTHER END

ILLUSTRATION NO. 16
RELEASING GRAIN FROM CARS EQUIPPED
WITH WOOD DOORS



SILLS PROVIDE EXCELLENT FOOTING FOR RAISING
LAST DOOR: BUT FIRST PRY BOTH ENDS OF
DOOR LOOSE FROM POSTS

THIS PAGE LEFT BLANK INTENTIONALLY